

Monographs for Teachers

A series of paperbound books which present concise and authoritative accounts of selected well-defined topics in chemistry for the guidance of teachers and students of further and higher education.

- No. 2 Principles of Oxidation and Reduction (2nd Edition) by A. G. Sharp
40pp 3 diagrams 0 85404 026 9 60p
- No. 3 Principles of the Extraction of Metals by D. J. G. Ives
58pp 16 diagrams 0 85404 023 4 £1.20
- No. 7 Principles of Catalysis (Revised 2nd Edition in SI Units) by G. C. Bond
72pp 33 diagrams 0 85186 789 8 £1.00
- No. 9 Principles of Reaction Kinetics (Revised 2nd Edition in SI Units) by P. G. Ashmore
84pp 10 diagrams 0 85404 024 2 80p
- No. 13 Principles of Osmotic Phenomena by J. F. Thain
74pp 12 diagrams 0 85404 025 0 40p
- No. 15 Physicochemical Quantities and Units (2nd Edition) by M. L. McGlashan
128pp 0 85404 009 9 70p
- No. 16 Chemical Processing in Industry by M. D. Wynne
34pp 15 photographs and diagrams 0 85404 007 2 40p
- No. 17 An Introduction to Biochemistry by E. G. Brown
116pp 28 diagrams 0 85404 016 1 70p (Library edition 0 85404 015 3 £1.40)
- No. 18 Principles of Crystal Chemistry by E. Cartmel
72pp 32 diagrams 0 85404 018 8 60p (Library edition 0 85404 017 X £1.20)
- No. 19 The Molecular Basis of Entropy and Chemical Equilibrium by P. A. H. Wyatt
72pp 12 diagrams 0 85404 020 X 50p (Library edition 0 85404 019 6 £1.00)
- No. 20 Silicon Chemistry and Applications by C. A. Pearce
74pp 30 diagrams 0 85404 022 6 £1.00
- No. 21 Modern Analytical Methods by D. Betteridge and H. E. Hallam
234pp 75 diagrams 0 85186 759 6 £2.00
- No. 22 Principles of Photochemistry by P. Suppan
70pp 40 diagrams 0 85186 769 3 £1.00
- No. 23 Chemical Aspects of the Atomic Nucleus by J. G. Cuninghame
115pp 55 diagrams 0 85186 779 0 £1.20
- No. 24 Principles of Free Radical Chemistry by J. I. G. Cadogan
83pp 5 diagrams 0 85186 829 0 £1.00
- No. 25 Some Aspects of Technological Economics by D. F. Ball
90pp 37 diagrams 0 85186 879 7 £1.00
- No. 26 Elements of Organometallic Chemistry by F. R. Hartley
103pp 21 diagrams 0 85186 909 2 £1.20
- No. 27 The Hydrogen Bond and other Intermolecular Forces by J. Clare Speakman
40pp 7 diagrams 0 85186 991 X 60p
- No. 28 Some Aspects of Basic Polymer Science by D. A. Blackadder
64pp 12 diagrams 0 85186 939 4 £1.20
- No. 29 Ion-exchange: Introduction to Theory and Practice by R. W. Grimshaw and C. E. Harland
91pp 22 diagrams 0 85186 969 6 £1.60
- No. 30 Molecular Structure: Its Study by Crystal Diffraction By J. Clare Speakman
57pp 13 diagrams 0 85186 689 1 £1.20
- No. 31 The Principles of Bioinorganic Chemistry by A. M. Fiabane and D. R. Williams
114pp 0 85186 679 4 £2.00

Orders to: The Chemical Society, Distribution Centre,
Blackhorse Road, Letchworth, Herts SG6 1HN.

REACTION PATHWAYS of CARBOXYLIC ACID DERIVATIVES

Peter Sykes



ETSG

CHEMISTRY CASSETTE

CHEMISTRY CASSETTES

General Editor:
Peter Groves
The University of Aston in Birmingham

Published 1979 by the Educational Techniques Subject Group, The Chemical Society, London.

© Peter Sykes 1979

ISBN 0 85186 640 9

All Chemistry Cassette materials are copyright and the tape recording and book may not be copied or reproduced in any way without the written permission of the Educational Techniques Subject Group. The materials are sold on the express condition that they are to be used for educational purposes only. They may not be used for commercial gain or be hired out for this or any other purpose without the prior written permission of the Educational Techniques Subject Group.

The views expressed in the recording and the book are those of the author and not necessarily those of the Chemical Society.

CHEMICAL SOCIETY LIBRARY	
Class No.....
..... 541.124 : 547.29
Acc. No. 780233.....
Source.....
Date 29. 8. 79. Price.....

Please read this carefully before you start.

USING THE CHEMISTRY CASSETTE

This Chemistry Cassette learning programme has two components, the audio-cassette and this book. The two are designed to be used together and you should always have the book with you as you work through the cassette. As you listen to the cassette you will, from time to time, be asked to switch off the player and answer some questions. You should, therefore, have pen and paper ready before you start.

The material in the book consists of reaction schemes, figures and equations, each of which is clearly numbered. Dr Sykes refers to these by section numbers and you should locate the relevant section, and study its contents, whenever it is referred to. Because some of the questions asked are answered in subsequent reaction schemes you are advised to use a piece of card or paper to cover any schemes beyond the last one mentioned.

Tape recorded material has the important feature of being self-pacing, which means that you can work through it at a pace related to your own needs and understanding. You can switch off the player whenever you want to think, to write some notes or to answer a question. You can use the rewind control to revise or to repeat material that you may not have fully understood on a first hearing. To gain the greatest benefit from this programme you should make full use of these features. You should also, whenever appropriate, make notes to supplement the material contained in the book. You will thereby build up a detailed set of personal notes which will serve as an authoritative guide to the subject.

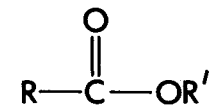

①

STRUCTURE OF AN ESTER

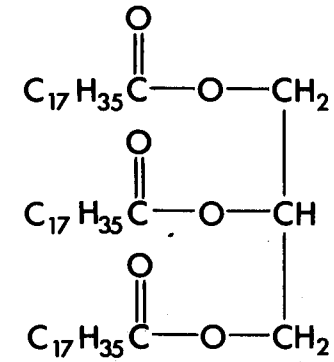

②

A TYPICAL FAT : TRISTEARIN (BEEF FAT)

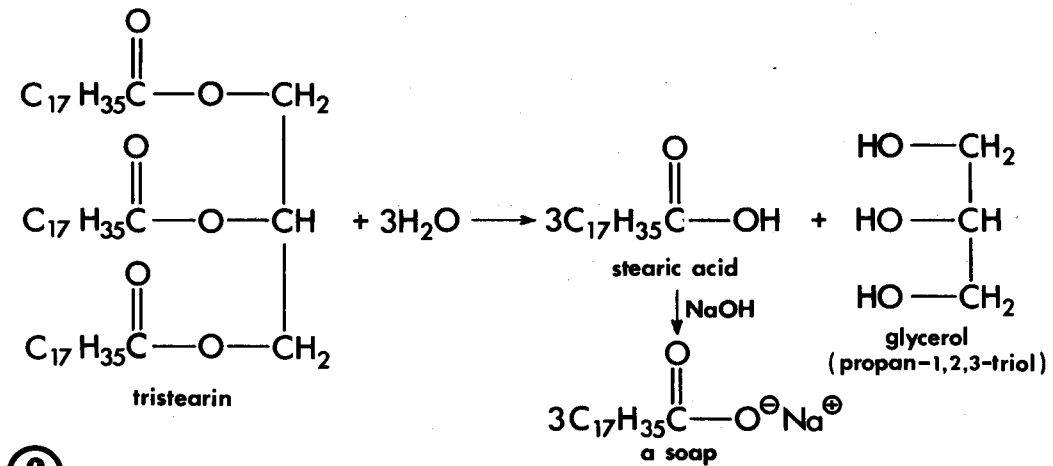

③

SAPONIFICATION (HYDROLYSIS) OF A FAT

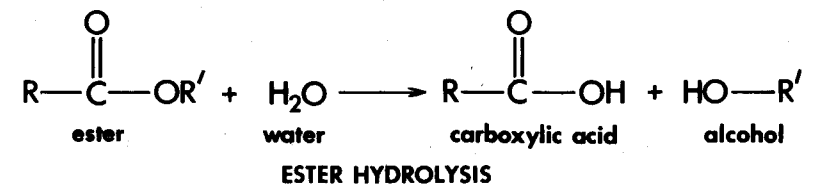

④

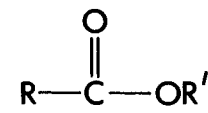

①

STRUCTURE OF AN ESTER

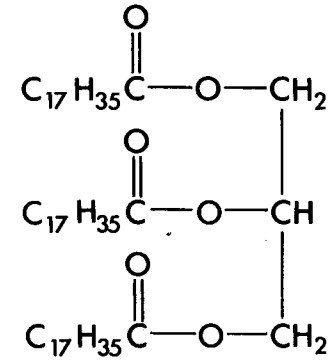

②

A TYPICAL FAT : TRISTEARIN (BEEF FAT)

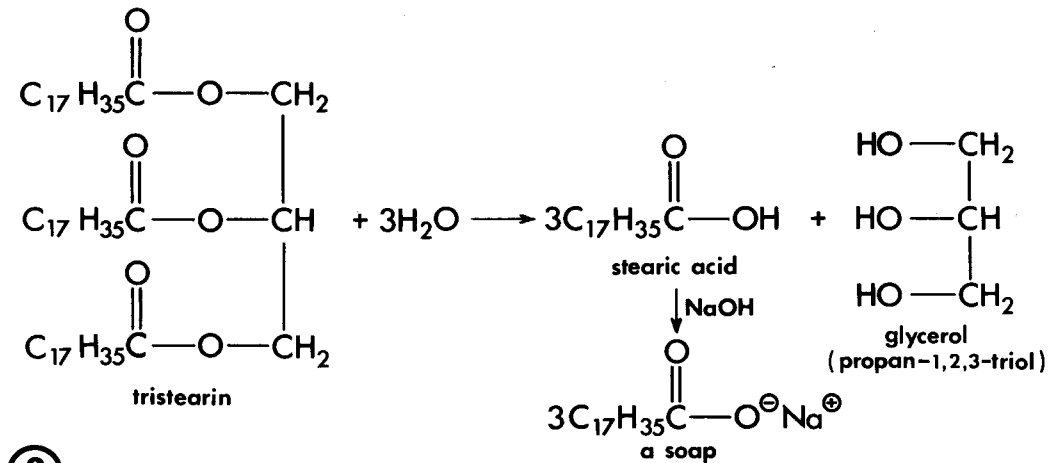

③

SAPONIFICATION (HYDROLYSIS) OF A FAT

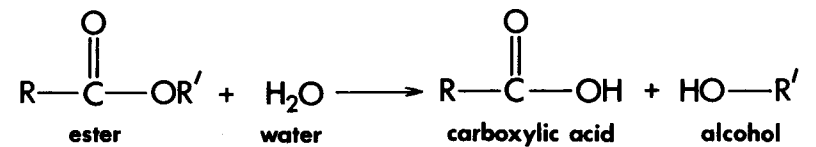

④

ESTER HYDROLYSIS

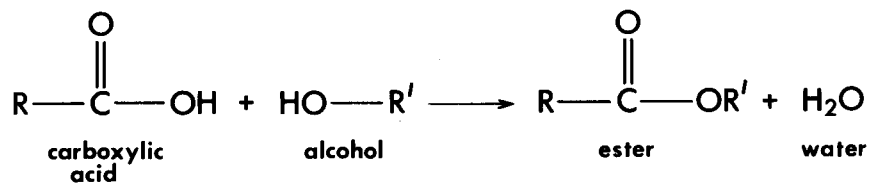

5 ESTER FORMATION : ESTERIFICATION

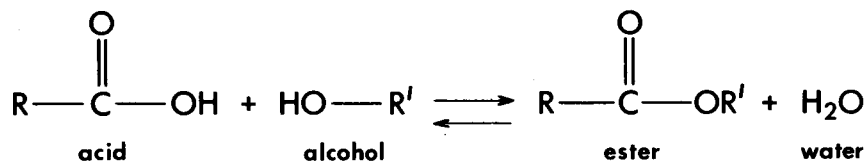

6 ESTERIFICATION/HYDROLYSIS : EQUILIBRIUM

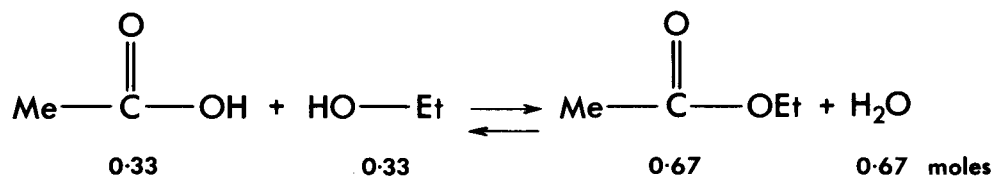

7 EQUILIBRIUM POSITION : ESTERIFICATION/HYDROLYSIS

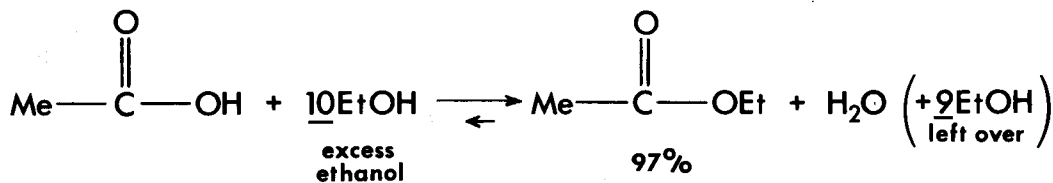

8 EQUILIBRIUM POSITION : EXCESS EtOH

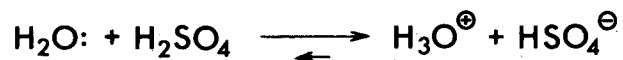

9 PROTONATION OF H₂O: BY H₂SO₄

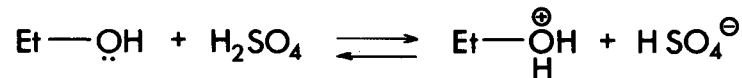

10 PROTONATION OF EtOH BY H₂SO₄

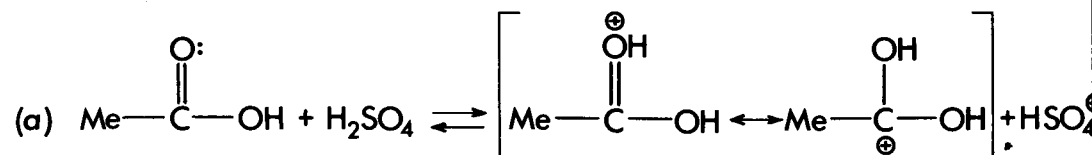

✓ carbonyl oxygen protonation

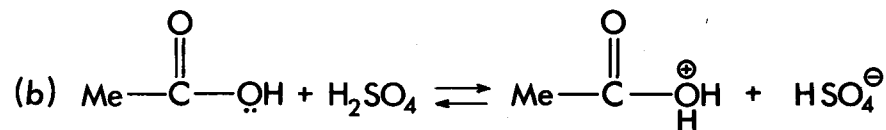

✗ hydroxyl oxygen protonation

11 ALTERNATIVE POSSIBLE PROTONATIONS OF ETHANOIC ACID

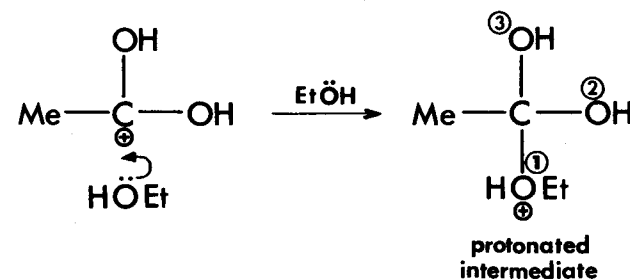

12 EtOH ATTACKING PROTONATED ACID

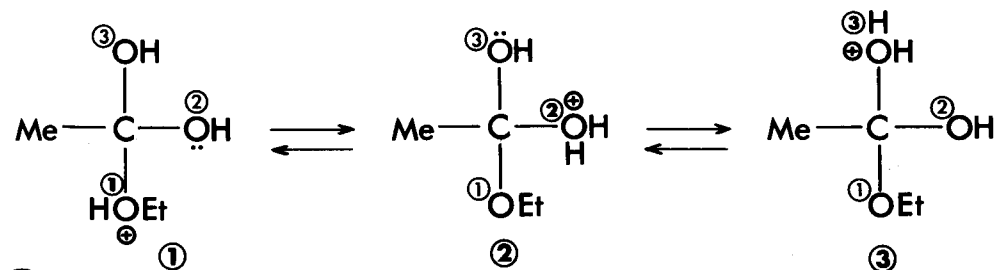

13 PROTON EXCHANGE IN PROTONATED INTERMEDIATES

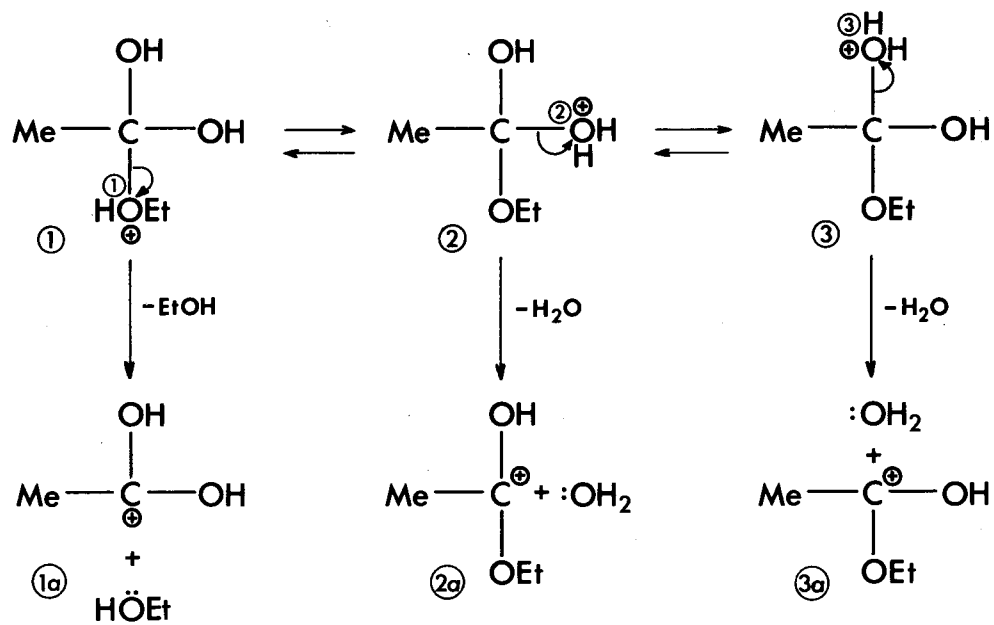

14 LOSS OF LEAVING GROUP FROM PROTONATED INTERMEDIATES

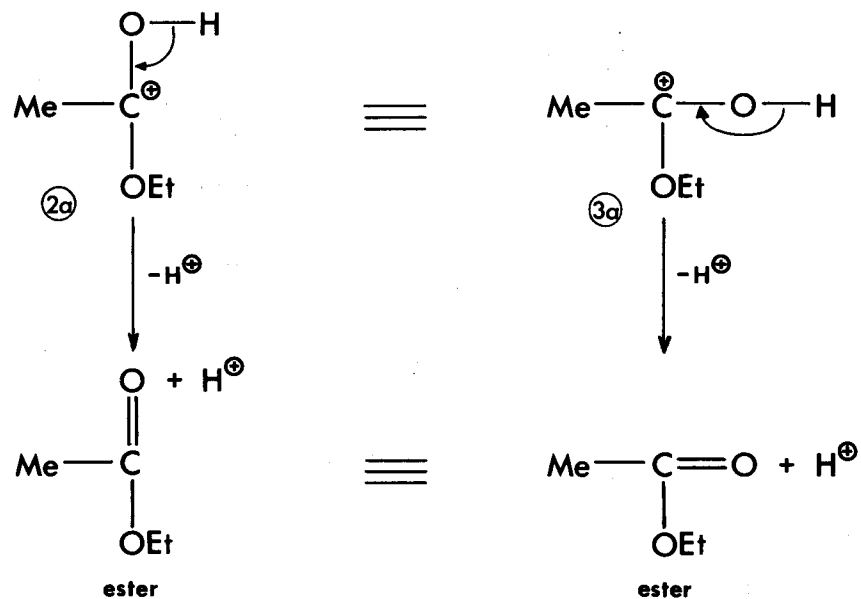

15 FINAL LOSS OF PROTON TO FORM ESTER

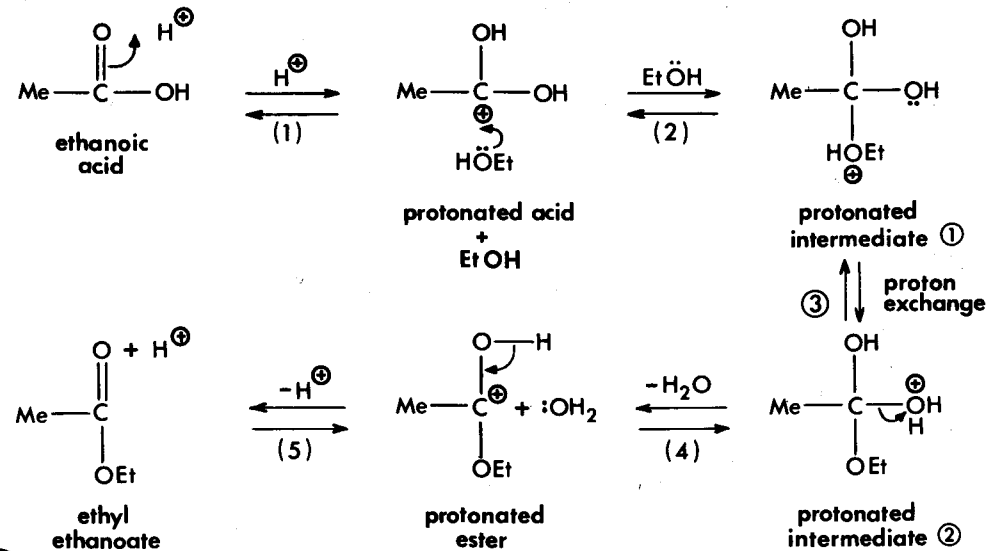

16 ACID-CATALYSED ESTER FORMATION/HYDROLYSIS

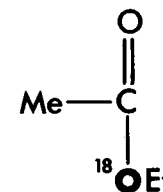

17 ETHYL ETHANOATE: ¹⁸O LABELLED AT ALKYL OXYGEN

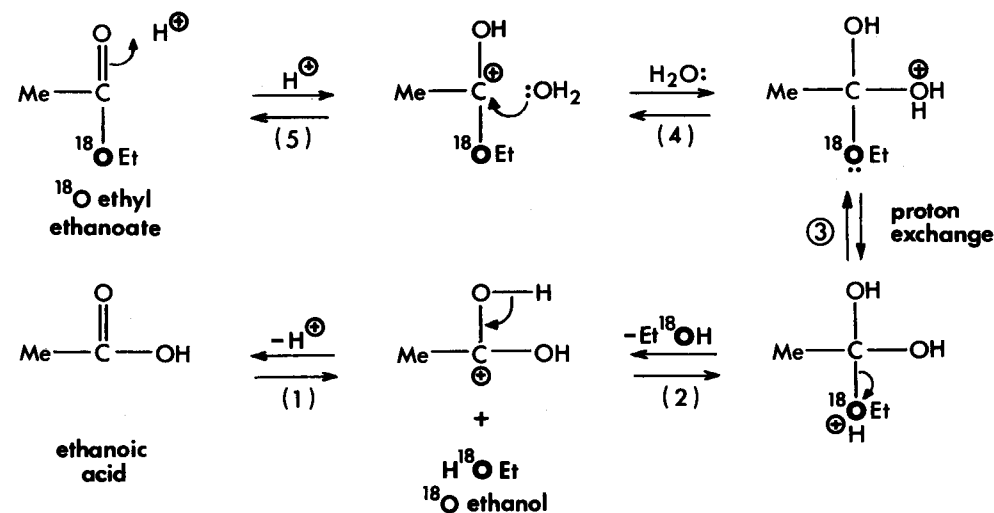

18 HYDROLYSIS OF ¹⁸O LABELLED ESTER → H¹⁸OEt

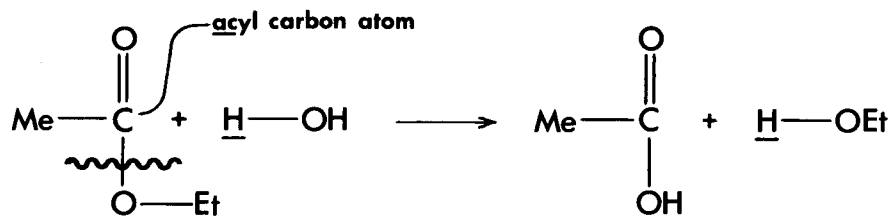

19

ACYL/OXYGEN (AC) CLEAVAGE OF ESTERS

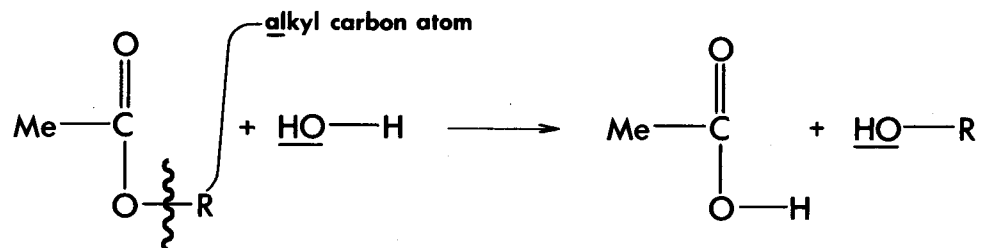

20

ALKYL/OXYGEN (AL) CLEAVAGE OF ESTERS

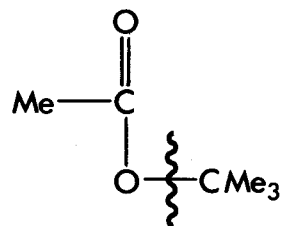

21

ALKYL/OXYGEN (AL) CLEAVAGE OF t-BUTYL ESTER

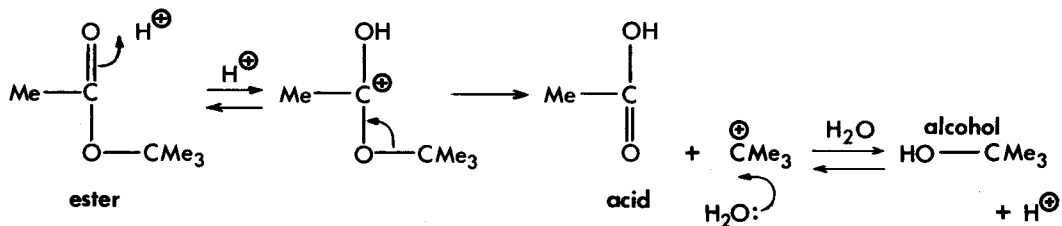

22

POSSIBLE ALKYL/OXYGEN (A_{AL}) HYDROLYSIS PATHWAY

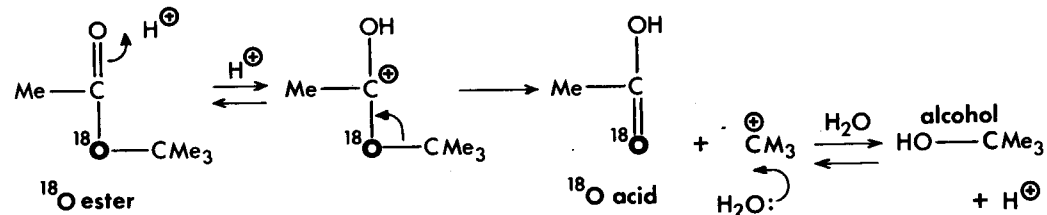

23

A_{AL} HYDROLYSIS OF ¹⁸O LABELLED ESTER → Me-¹⁸O-C-OH

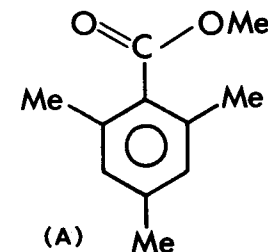

24

METHYL ESTER (A) OF AN AROMATIC ACID

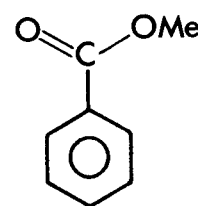

(B)

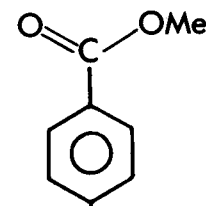

(C)

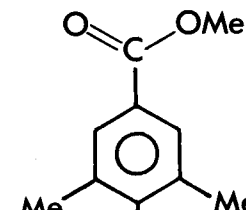

(D)

25

METHYL ESTERS OF THREE MORE AROMATIC ACIDS

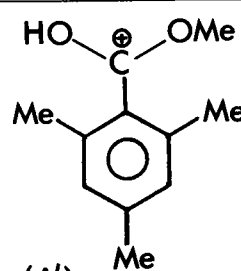

(A')

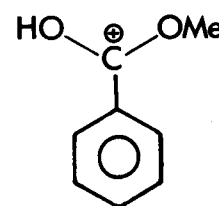

(B')

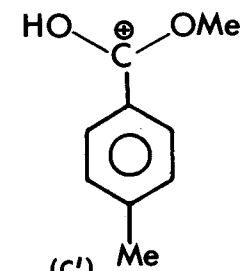

(C')

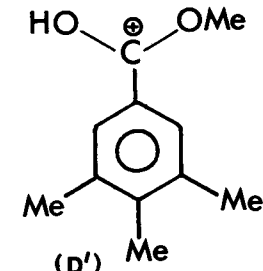

(D')

26

PROTONATED FORMS OF ALL FOUR ESTERS

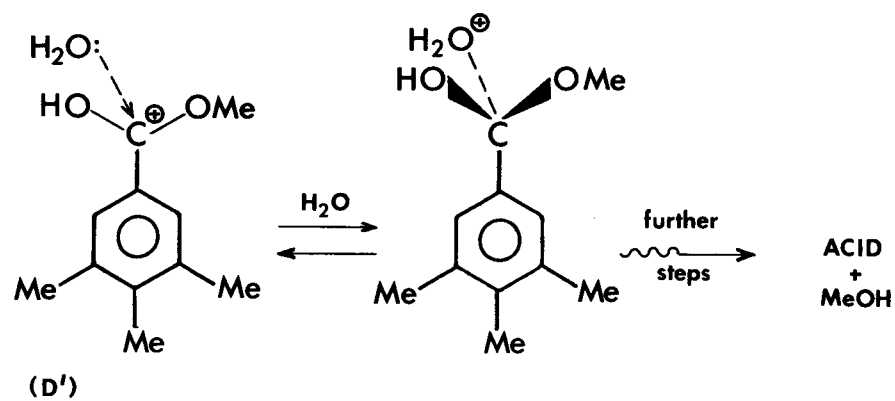

27

H₂O: ATTACK ON PROTONATED ESTER (D')

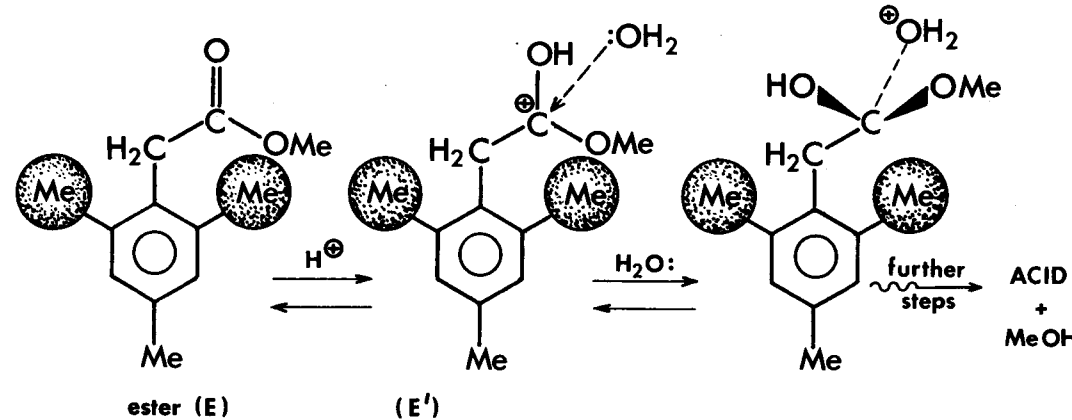

30

ACID HYDROLYSIS OF ESTER (E)

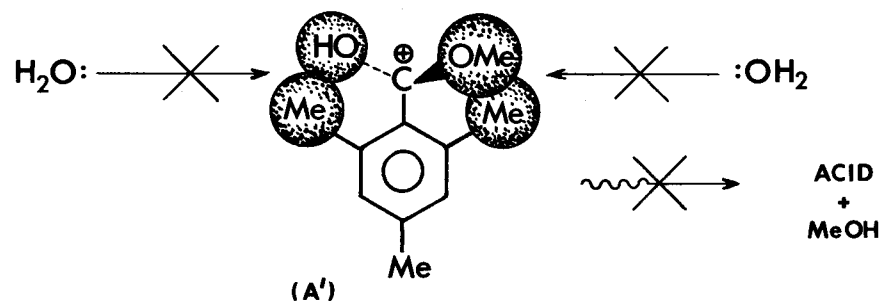

28

NO H₂O: ATTACK ON PROTONATED ESTER (A')

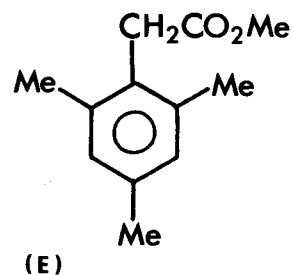

29

METHYL ESTER (E) OF YET ANOTHER AROMATIC ACID!

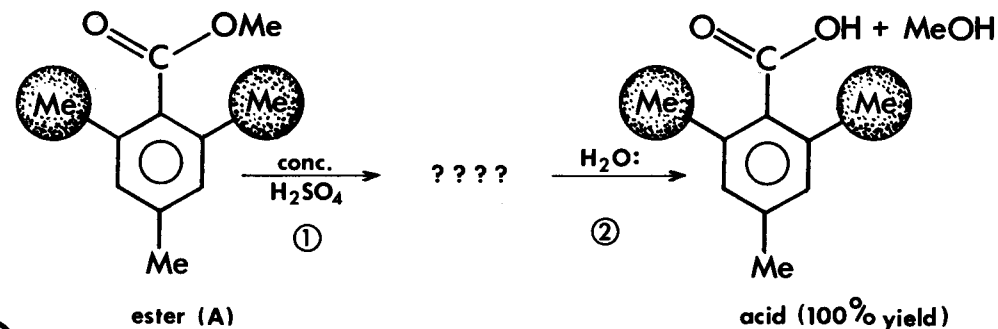

31

ACID HYDROLYSIS (CONC H₂SO₄) OF ESTER (A)

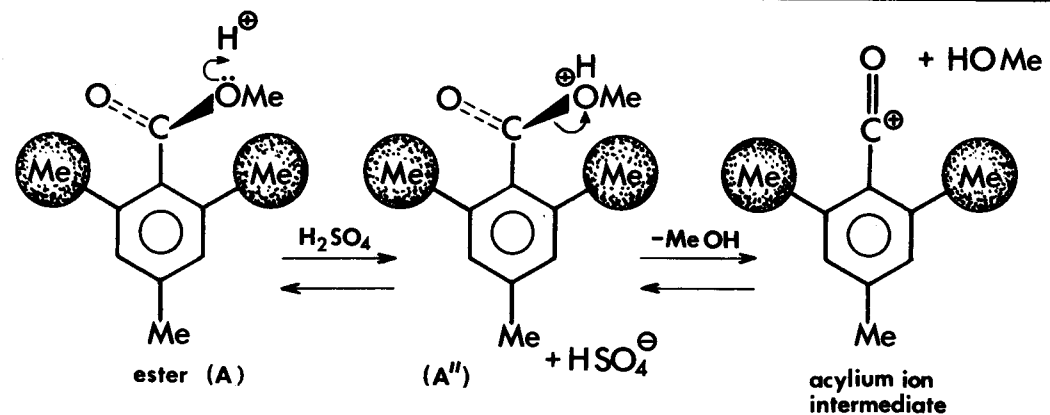

32

ACYLIUM ION INTERMEDIATE FROM ESTER (A)

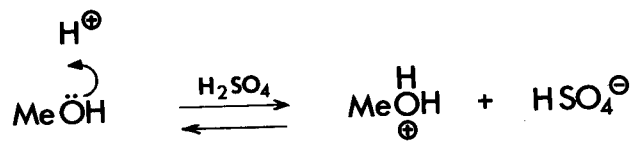

PROTONATION OF MeOH

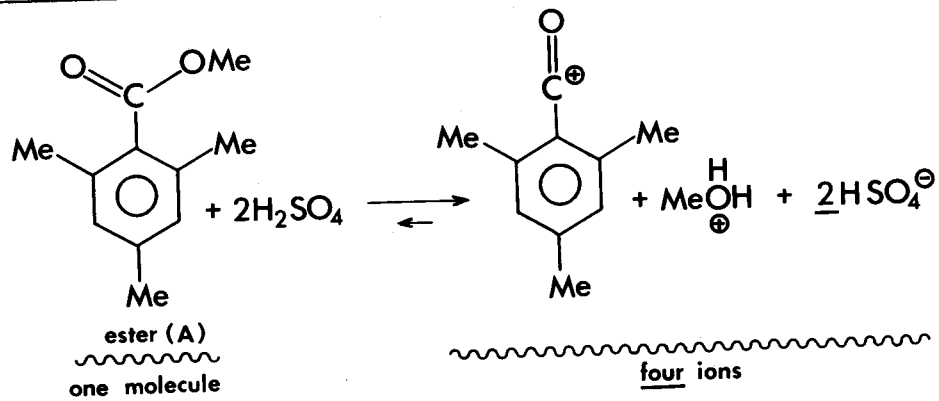

ESTER (A) + CONC. H₂SO₄ → FOUR IONS

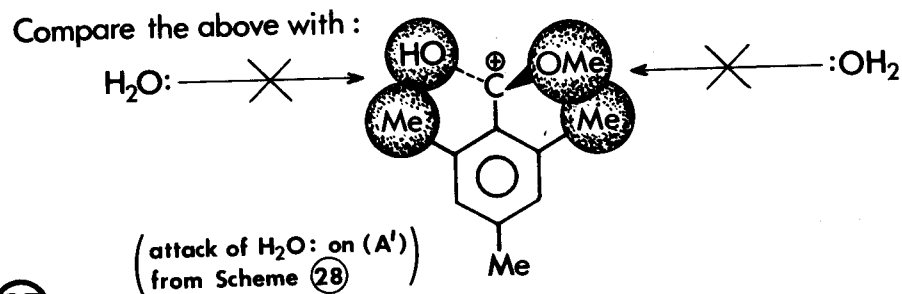
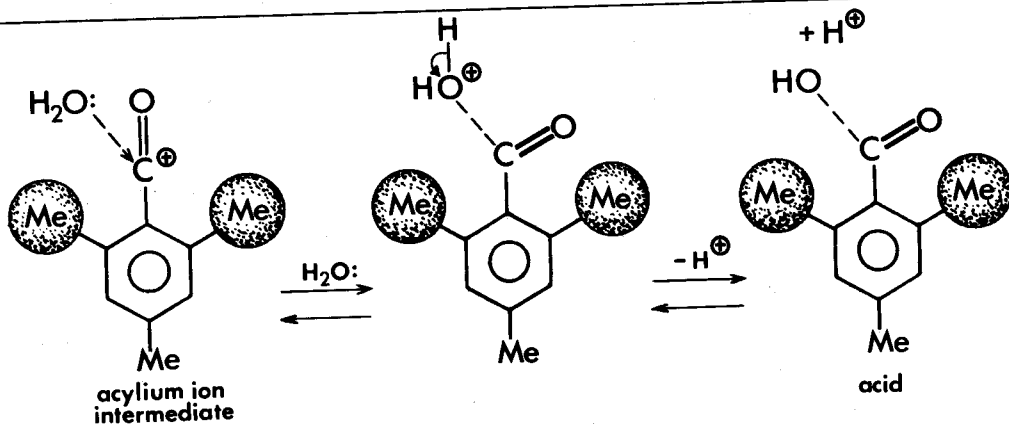

ATTACK OF H₂O: ON ACYLIUM ION INTERMEDIATE

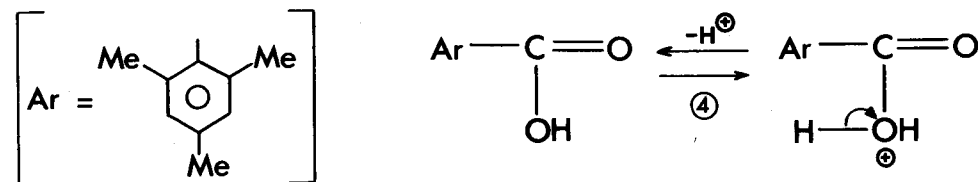
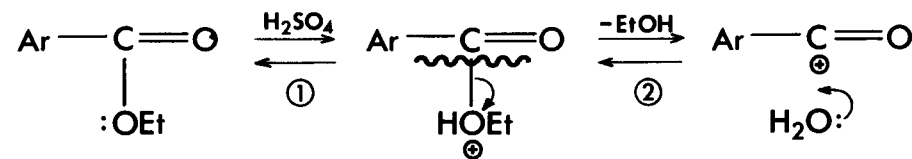

(i) A_{AC} : PATHWAY X

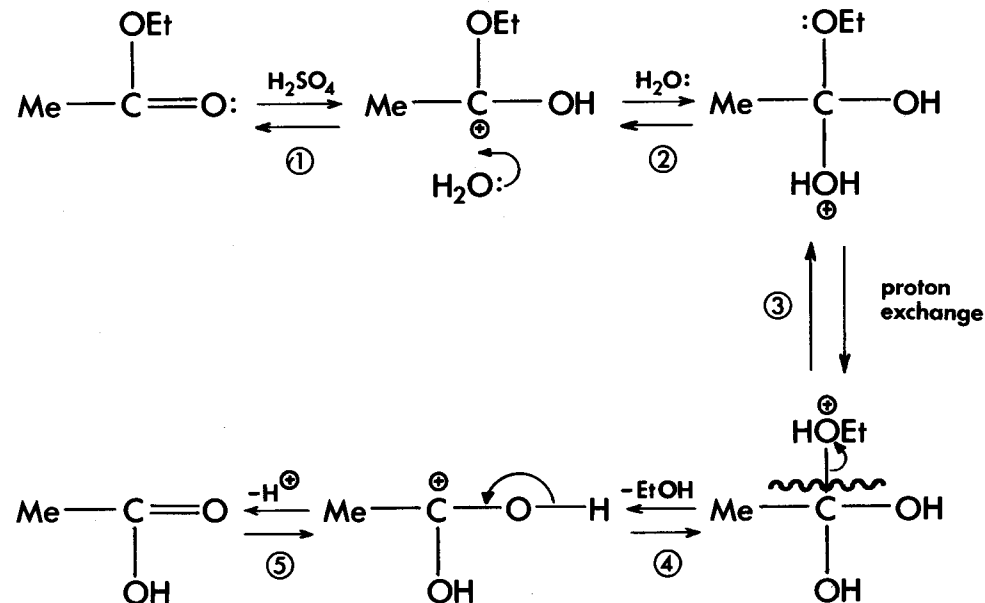

(ii) A_{AC} : PATHWAY Y

A_{AC} HYDROLYSIS: (i) AROMATIC ESTER; (ii) ETHYL ETHANOATE

33

34

35

36

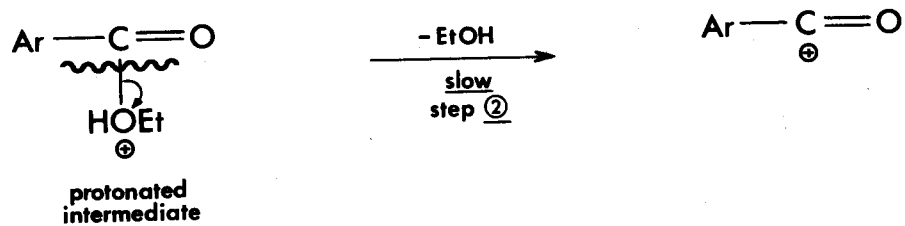

PATHWAY X: A_{AC}1

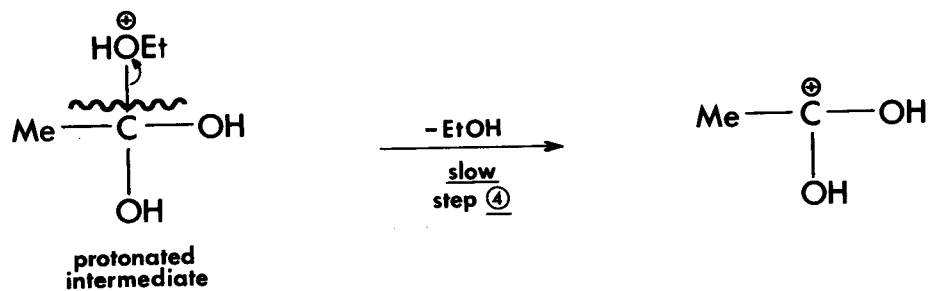

PATHWAY Y: A_{AC}2

RATE-LIMITING STEPS: PATHWAYS X(A_{AC}1) AND Y(A_{AC}2)

37

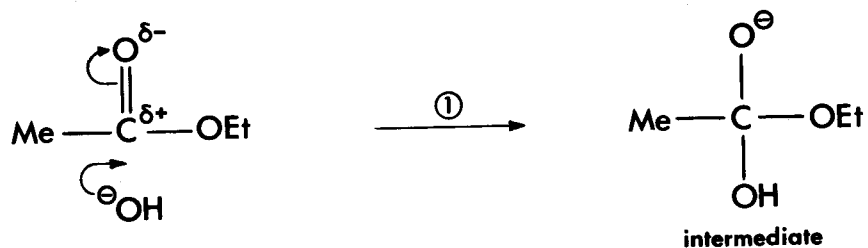

NUCLEOPHILIC ATTACK BY OH^- ON $\text{C}=\text{O}$ IN ESTER

38

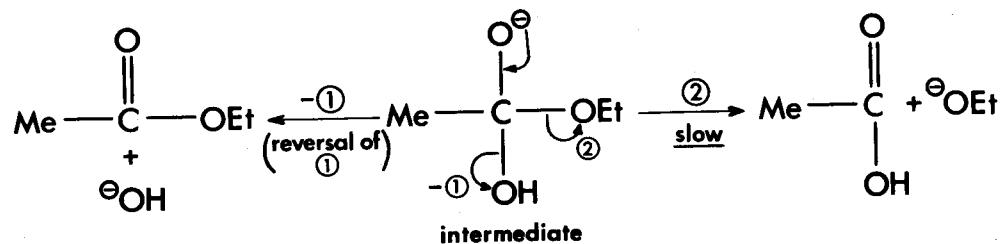

POSSIBLE FATES OF NEGATIVELY CHARGED INTERMEDIATE

39

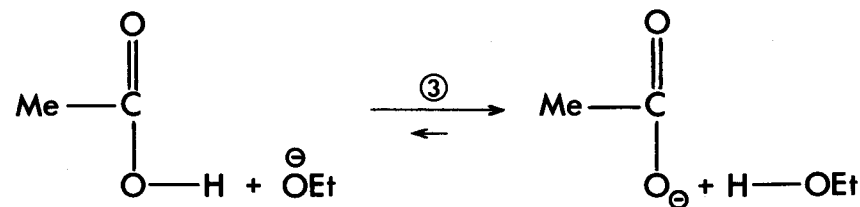

MeCO₂H v. EtOH : STRENGTHS AS ACIDS

40

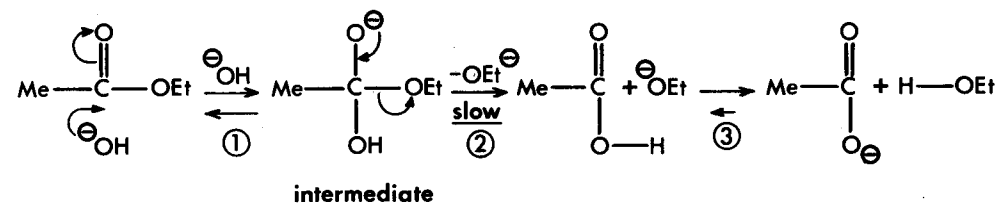

BASE-CATALYSED ESTER HYDROLYSIS : B_{AC}2 PATHWAY

41

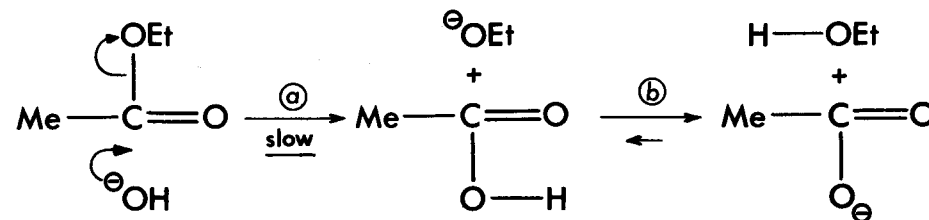

HYDROLYSIS BY DIRECT DISPLACEMENT PATHWAY

42

(i) LiAlH_4 :

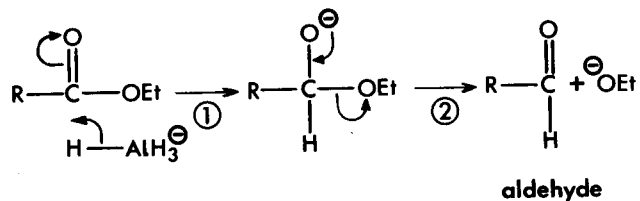

(ii) $\text{R}'\text{MgBr}$:

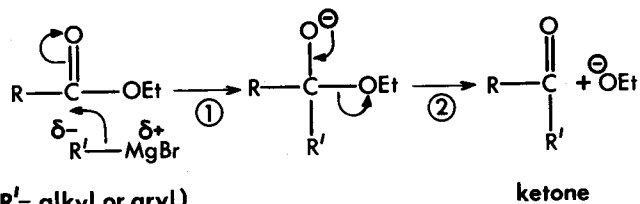

($\text{R}' = \text{alkyl or aryl}$)

50

NUCLEOPHILIC ATTACK BY LiAlH_4 AND $\text{R}'\text{MgBr}$

(i) LiAlH_4 (cont):

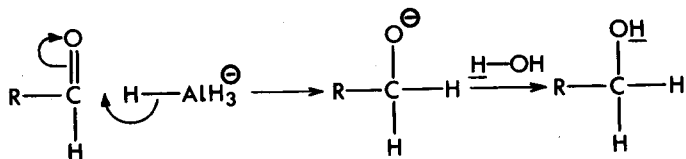

(ii) $\text{R}'\text{MgBr}$ (cont):

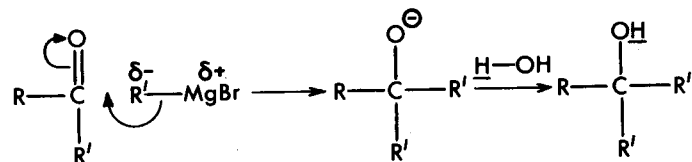

51

CONTINUATION OF NUCLEOPHILIC ATTACK

Reagent added:	NaCl	NH_3	NaOH	LiAlH_4	RMgBr
Potential nucleophile:	Cl^\ominus	$:\text{NH}_3$	$^\ominus\text{OH}$	AlH_4^\ominus	R^\ominus
Relative basic strength: (log scale)	1	10	15	≈ 40	≈ 40

52

RELATIVE BASIC STRENGTH OF SOME NUCLEOPHILES

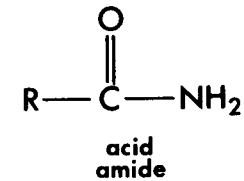
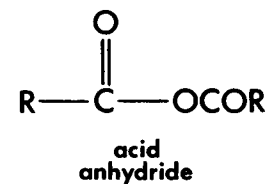
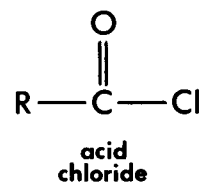

53

SOME OTHER CARBOXYLIC ACID DERIVATIVES

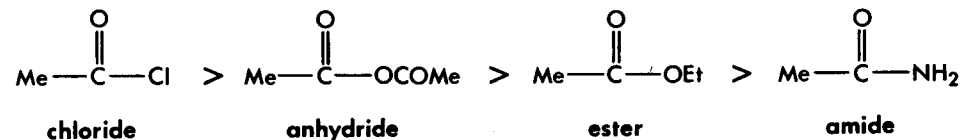

54

RELATIVE REACTIVITY OF ETHANOIC ACID DERIVATIVES

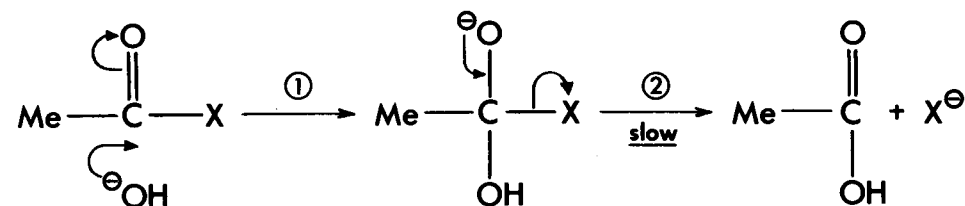

55

REACTION OF $^\ominus\text{OH}$ WITH $\text{R}-\overset{\text{O}}{\parallel}{\text{C}}-\text{X}$

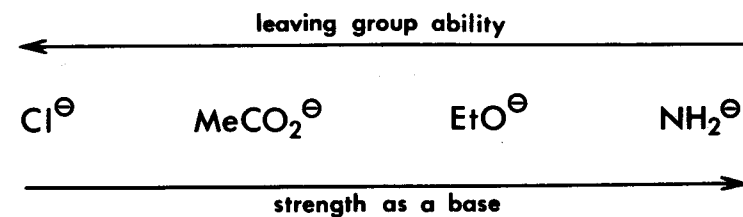

56

RELATIVE LEAVING GROUP ABILITY / BASIC STRENGTH OF X^\ominus

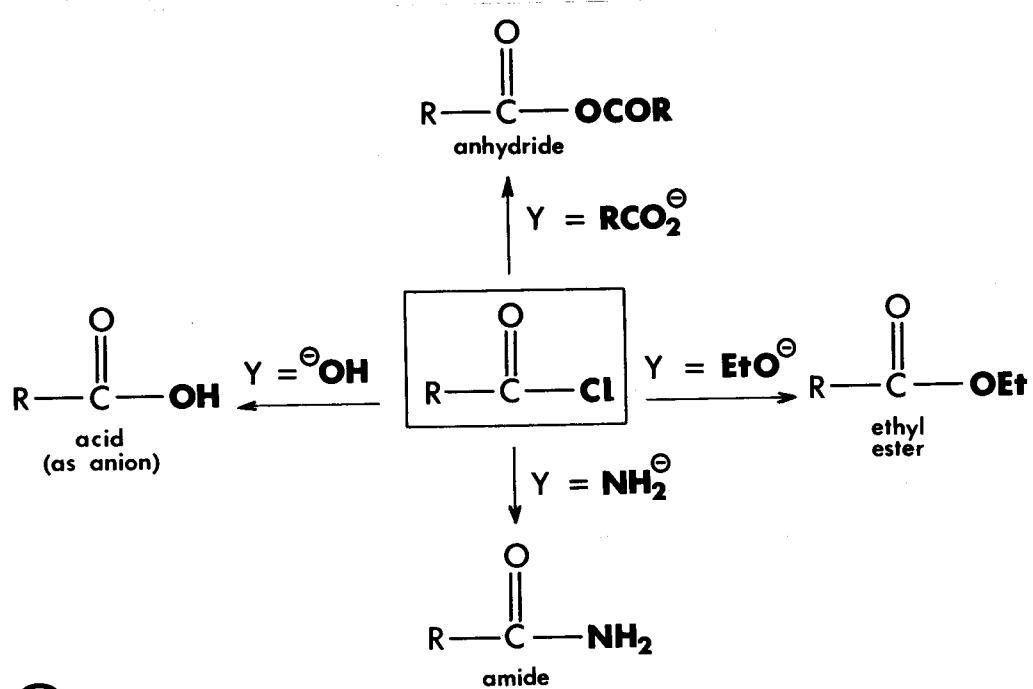

57

NUCLEOPHILIC REPLACEMENTS OF Cl^\ominus IN RCOCl

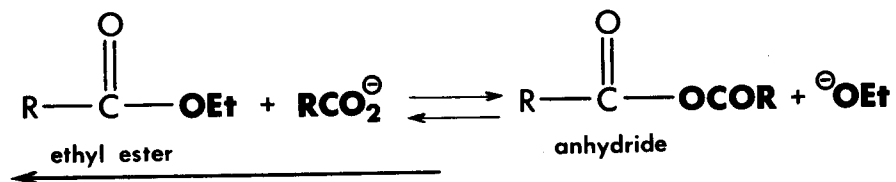
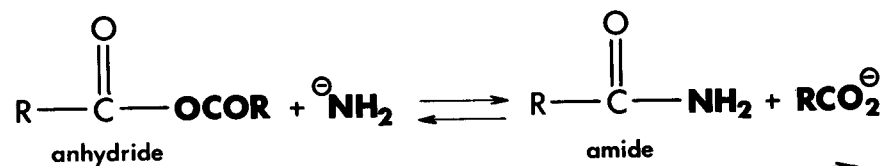

58

INTERCONVERSIONS OF CARBOXYLIC ACID DERIVATIVES

