



Historical Group

OCCASIONAL PAPERS

No 7

Nitrogen, Novel High-Pressure Chemistry, and the German War Effort (1900-1918)

Anthony S. Travis

(Sidney M. Edelstein Center for the History and Philosophy of Science, Technology and Medicine,
The Hebrew University of Jerusalem)

The Seventh Wheeler Lecture

Royal Society of Chemistry, 22 October 2014

April 2015

Introduction

“The story still is told of a Minister, a member of the War Cabinet, who, finding the conversation at a certain dinner turning to the sinister menace of the submarine campaign, then at its height, and its effects especially on the Chile communications, turned to his neighbour with the enquiry: ‘Tell me, what *is* this nitrate they are all making such a fuss about?’”

Stanley I. Levy, “The Status of Chemists and Chemistry”, in *Chemistry and Industry*, no. 11 (14 March 1924): 285-6.

Apocryphal or not, this extract from the correspondence columns of the then new British journal *Chemistry and Industry* in 1924 exposes the apparent general ignorance in Britain, and also for a time in Germany, of a crucial and even desperate episode in the conduct of what became known as the First Great War. “Nitrate”, a commodity essential to the production of modern explosives employed in warfare, mainly aromatic nitro compounds such as TNT and picric acid, was common currency to all belligerents. Nevertheless outside of scientific and industrial circles the critical roles of what was in fact Chilean nitrate (Chilean saltpetre, or sodium nitrate), extracted from the mineral caliche, and the other nitrogen-containing chemicals of commerce, such as calcium cyanamide and ammonia, as sources of vast destructive power, was generally given little, if any, prominence at the start of the war in early August 1914.

It was the military stalemate reached in September 1914 that led to immediate and unprecedented demand for these chemicals, nitric acid, and coal tar aromatics. That demand became even more urgent in Germany when at the end of the year, through the efforts of the British Royal Navy, German manufacturers of nitric acid and explosives were denied direct access to Chilean saltpetre. From then on the Kaiser’s chemists and industrialists gave top priority to the capture of atmospheric nitrogen. This was the turning point in the modern manufacture of nitrogen products. State sponsorship of and industrial investment in essential nitrogen products enabled the construction of vast chemical works for the purposes of war, but with the potential of no less vast markets after the war. German science and technology succeeded magnificently, something over which even the Allies were in agreement. Moreover, and as a measure of the complexities overcome by German scientists and technologists, their achievements could not be matched elsewhere. Fortunately for the Allied nations, they could continue to rely on the natural nitrates, despite submarine attacks on merchant shipping. In many respects, the impact during the years immediately following cessation of hostilities was no less great, as Germany’s former enemies fought to catch up in nitrogen fixation processes and the development of high-pressure chemical technology that it spawned.

In late 1914, the situation was very different. Fortunately for the Germans there were available novel technical processes, based on studies undertaken during the previous decade that could, through improvements, be adapted to a war economy. What follows is an account of their developments prior to 1914, and subsequent applications until 1918.

Until 1914, Chilean saltpetre supplied two-thirds of the world’s supply of fixed nitrogen fertilizer. Concerns over depletion of reserves of caliche, and the Chilean monopoly over the saltpetre extracted from caliche, stimulated European scientists and inventors to explore the direct fixation of atmospheric nitrogen. In Britain they included Sir William Crookes (1832-1919), who in 1898, in his presidential address to the British Association for the Advancement of Science at Bristol, spoke of a Malthusian threat represented by an impending fertilizer crisis once the deposits of caliche were spent. Crookes’ observations on “The World’s Wheat Supply”, which predicted certain doom unless the nitrogen problem was solved, were widely publicized. Not everyone however agreed with his prognosis. Some thought that he was given to over-exaggeration (Crookes 1900). Estimates of reserves varied from two decades to half a century and in the case of the nitrate industry to over a century.

Electric Arcs

By the mid-1890s, scientific and technical interest in electrochemistry was already aroused among those inventors interested in fixing atmospheric nitrogen. The growing availability of low-cost hydroelectricity encouraged investigations of electrothermal reactions for use on an industrial scale. The main limitation was the lack of reliable high voltage transmission systems, which restricted the geographical distribution of any technically viable processes to localities that offered hydroelectric power, or access to sources of inexpensive coal. In 1897, Lord Rayleigh (1842-1919), following studies of William Crookes and others, suggested the technical combination of nitrogen with oxygen in an electric arc, which directed studies into gaseous electrothermics.

Success was first achieved in 1903, after Norwegian physicist and inventor Kristian Olaf Bernhard Birkeland (1867-1917), at the University of Kristiania (now Oslo), met engineer Samuel Eyde (1866-1940) during a dinner party at the home of Norwegian cabinet minister (and later prime minister) Gunnar Knudsen (1848-1928). Birkeland was a keen explorer and inventor, with an interest in electromagnetic devices, including a cannon of his own design. Eyde had studied engineering in Berlin, and then worked on railway construction projects, prior to forming the successful engineering firm of Gleim & Eyde. At Knudsen’s party, Eyde, no doubt knowing of Birkeland’s work with electromagnetism, suggested the capture of atmospheric nitrogen by the most powerful flash of artificial lightning that could be produced. Birkeland, perhaps inspired by a massive short circuit that had occurred while testing his cannon, responded by devising an electric arc that simulated lightning, enabling capture of nitrogen in what appeared to be a technically viable method. Subsequently Birkeland and Eyde developed what became known as the Birkeland-Eyde electric arc process. In this process an electromagnetic field concentrated the discharge, which, as in other arc processes, was turned into a flame when subjected to blasts or currents of air. Birkeland’s electric sun was a two-metre disc of flame created when an alternating current was deflected by a magnetic field such that it was at right angles to the

electrodes (**Figure 1**). This arrangement enabled the working of large furnaces. The atmospheric nitrogen was captured as nitric oxide. A prototype was constructed at Arendal, Eyde's birthplace.

Figure 1. Birkeland and Eyde electric arc process (Travis, 1984)

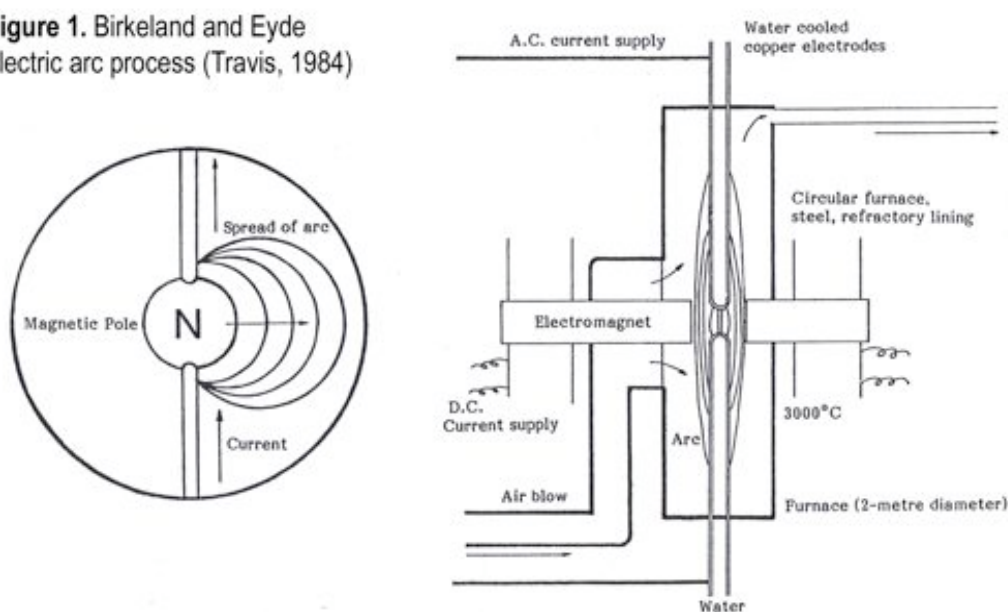

At the end of 1903, Birkeland and Eyde, jointly with the Swedish bankers Knut and Marcus Wallenberg, backed by the Enskilda Bank, Stockholm, set up the firm Elektrokemisk, followed by Notodden Saltpeterfabriker AG (1904) to undertake manufacture at Notodden, in Telemark, southwest of Oslo. On 2 May 1905, work started on a small factory, with three 500-kilowatt furnaces. Power for the Birkeland-Eyde process was supplied by the Tinfos hydroelectric station, opened in 1901.

The gas leaving the electric arc furnaces contained two to three per cent of nitric oxide. Rapid quenching in an aluminium vessel lowered the temperature, in order to prevent decomposition of the oxide. The cooled gas was passed through oxidation chambers, vertical iron tanks lined with acid-proof stone, to form dioxide, and then through an absorption system where the dioxide was converted into nitric acid.

Details of the Birkeland-Eyde process were described by the chemist Otto N. Witt (1853-1915) on 25 November 1905 at the inauguration of the new technical chemistry institute at the Royal Technical College of Berlin (Königliche Technische Hochschule zu Berlin, also known as the Technische Hochschule Charlottenberg). Witt had made his name as a dye chemist while working in England, in particular with the development of azo dyes and a theory of colour and constitution. He was now a leading promoter of electrochemistry, thoroughly familiar with the Norwegian process after serving as a consultant to Birkeland and Eyde. Following Crookes, Witt also warned of future shortages of nitrates, suggesting that they would begin to run out by the mid-1920s (Witt 1905). Birkeland and Eyde were in the audience, as were Heinrich von Brunck, managing director of Badische Anilin- und Soda-Fabrik (BASF), and his colleague the chemist Rudolf Kneitsch (1854-1906), all at that time committed to the capture of atmospheric nitrogen through electric arcs.

One week later, on 2 December 1905, Norsk Hydro-Elektrisk Kvälstofaktieselskab (Norwegian Hydroelectric Nitrogen Company), better known as Norsk Hydro, was founded with mainly French capital. Marcus Wallenberg was the first chairman of the board. The Birkeland-Eyde process was at the heart of what was to become Norway's first multinational corporation.

In October 1907, the much enlarged Notodden facility became engaged in full-scale commercial production of calcium nitrate (Norges-salpeter, Norwegian saltpetre, nitrate of lime, air-salpetre). Electricity came from the new Svelgfoss power station, five kilometres away, the largest in Europe, and the second largest in the world after that of the Ontario Power Company, at Niagara Falls.

In 1911, the Rjukan facility, some distance north of Notodden, was inaugurated. The chemical works was at Sâheim. Electricity was generated nearby, at the Rjukanfossen waterfall on the Måne River. This hydroelectric plant, also known as Rjukan I (1907-1911), was the largest power station in the world when built, generating 140,000 horsepower.

During 1912-1913, demand for Norwegian nitrogen doubled. An even larger power station at Sâheim (Rjukan II) was brought into operation in 1916, with nine generators supplying 167,000 horsepower to forty electric arc furnaces located in the same building

Also worked in Norway, jointly with Norsk Hydro, was the BASF electric arc process of Otto Schönherr (1861-1926). This came about following a meeting between Birkeland, Eyde, von Brunck, and Kneitsch in 1905 on the occasion of Witt's Berlin lecture. In 1905, Schönherr, in collaboration with the electrical engineer Johannes Hessberger (1871-1934), developed a long, slender discharge furnace, an iron pipe over twenty feet long, incorporating within concentric

iron pipes surrounding an inner electrode. From the absorption towers, forty per cent nitric acid was obtained, which was either further concentrated, or reacted with limestone to give calcium nitrate.

On 11 September 1906, Norsk Hydro, and its Swedish and French investors, signed an agreement with BASF, in partnership with Bayer and AGFA, the Dreibund, for joint developments at Rjukan. There were considerable polemics over the most suitable type, or the number of each type, of arc furnace, Birkeland-Eyde or BASF, to be installed. Relations quickly became strained. Eyde was opposed by the other partners, and forced to step down from involvement in the various concerns.

The yield of desired nitric oxide from the BASF electric arc was higher than from the Birkeland-Eyde arc. Also, the cost of the BASF furnace was lower, and repair and maintenance costs were not great. However, new and taller BASF furnaces were problematic in operation. In 1909, BASF commissioned the academic physicist Jonathan Zenneck (1871-1959) of Braunschweig to take up residence in Rjukan for some time in an effort to bring about improvements. In 1910, BASF consultant Fritz Haber was also called upon to assist. He and an assistant undertook experiments with a laboratory-size Schönherr electric arc furnace and found that an increase in pressure had no advantage. Little came out of these efforts. The Birkeland-Eyde furnaces were found to be more efficient than the newer BASF furnaces. BASF pulled out in 1911, already heavily involved in another, quite different, way of fixing nitrogen based on the work of Haber.

Several other arc processes were developed, including, in 1902, one by Harry Pauling, citizen of Brandau, Bohemia, Austria-Hungary, in which a stream of fast moving air was blown against an arc created between two diverging electrodes. This horn-arrester, based on the horn-break lightning arresting device, consisted of two hollow iron electrodes arranged to form a V. Air blown up through a nozzle into the lower part of the arc was deformed into a flame (Lunge 1916, vol. 1, pp. 253-256). The process was adopted in the furnaces of Salpetersäure-Industriegesellschaft Gelsenkirchen, of Cologne, at Patsch, near Innsbruck, from 1904, at La Nitrogène Cie., Roche-de-Rame, Hautes Alpes, France, in 1908, and at Legnano, near Milan, in 1911. All of these factories relied on hydroelectric power. The electric arcs were single phase. As elsewhere, nitric acid of thirty-five to forty per cent concentration was obtained from absorption towers, and was concentrated further by hot gases generated during the arc process. Harry Pauling worked in partnership with his brother, G. Pauling.

Cyanamide

Another approach that relied on cheap electrical power involved the reaction between calcium carbide (made from coal and lime in an electric furnace) and atmospheric nitrogen. In 1895, the study of the absorption of nitrogen by carbides was taken up in Germany by the chemists Adolph Frank (1834-1916) and Nikodem Caro (1871-1935). Frank studied pharmacy, chemistry and technology, and in 1863 received his doctorate in chemistry at Göttingen. In 1885 he became an independent consultant, with a special interest in the paper industry. Nikodem Caro (a relative of Heinrich Caro, the technical leader at BASF during the nineteenth century), grew up in Lodz, Upper Silesia. In 1888, he arrived in Berlin, where he studied chemistry at the Technische Hochschule Charlottenberg. In 1892, he was awarded his doctorate from the University of Rostock.

For Dynamit AG, Frank and Caro undertook research into a new method for making the sodium cyanide required in the extraction of gold. They heated barium or calcium carbide in a stream of nitrogen and found that both carbides absorbed nitrogen on heating. Their first patent, filed on 31 March 1895, was for barium cyanide. Though it mentioned in passing that calcium carbide absorbed nitrogen, the product was not identified. In 1898, chemist Fritz Rothe demonstrated that the nitrogen product from calcium carbide was calcium cyanamide, and a patent was filed for the cyanamide process. The calcium carbide had to be heated at 1,000 to 1,600°C in order to take up nitrogen.

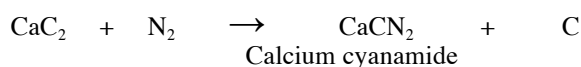

Frank, Caro and Rothe, together with Deutsche Bank, Siemens & Halske, and Deutsche Gold- und Silber-Scheideanstalt vormals Roessler (Degussa), founded in 1899 the Cyanidgesellschaft mbH in Berlin. The factory was in Frankfurt. The crude calcium cyanamide was converted into cyanide by fusion when mixed with calcium carbide and sodium chloride in an arc furnace, followed by rapid chilling of the melt. The carbide prevented loss of nitrogen at the high temperature required. The resulting sodium cyanide was used in gold extraction and was converted to hydrogen cyanide for application as a fumigant.

In 1901 Frank's son, Albert Rudolph Frank (1872-1965), and Hermann Freudenberg suggested that calcium cyanamide be employed as a fertilizer, after Caro a year earlier found that calcium cyanamide in the presence of water released ammonia in the soil. Also, if heated with steam it decomposed to give ammonia.

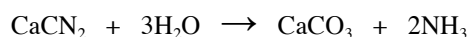

The Cyanidgesellschaft was reorganized under the management of Albert Frank and Freudenberg. A pilot plant was set up at Spandau, Germany, followed, around 1905, by a factory, with an intended initial capacity of 500 tons per year, in central Italy at Piano d'Orta, Abruzzo, making use of hydroelectric power. These first attempts ended in failure because of the limited lifetime of the externally heated retorts. Adolph Frank then developed electric ovens incorporating carbon "pencil" electrodes, inserted into the drums of carbide (**Figure 2**). In 1907 the Italian factory, now fitted with self-heating ovens, commenced production at the rate of 4,000 tons of calcium cyanamide per year.

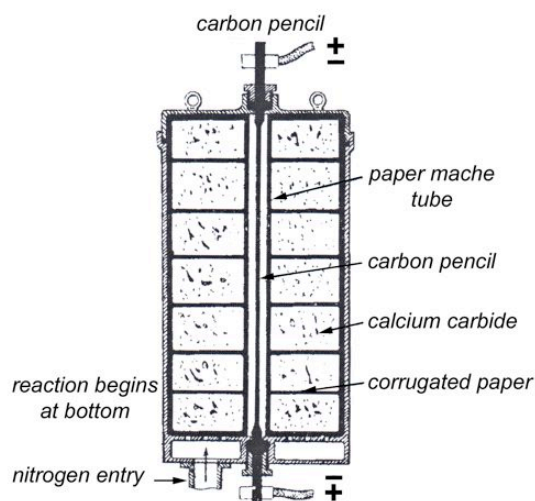

Figure 2: Early Frank-Caro Electric Oven for Calcium Cyanamide (redrawn from Ernest Kilburn Scott, *Nature*, 11 July 1912, p. 492).

In the improved cyanamide process, the absorption of nitrogen took place at the point of contact of the pencil with the carbide and continued gradually outward. After around twenty-five hours the current was switched off, and the furnaces left a further ten hours, by which time the nitrogen had been absorbed. The calcium cyanamide, appearing as a black-grey clinker, was turned out, crushed, ground, and packed in bags for shipping. The high operating temperature kept the power cost high.

That changed with the introduction of a rival cyanamide process, developed in 1901 by Austro-Hungarian chemist Ferdinand Eduard Polzenius (1862-1918). He overcame the furnace difficulties, mainly the high temperature requirement, by introducing calcium chloride as a catalyst. This enabled reduction of the operating temperature to 700-800°C. With inventor Constantin Krauss, Polzenius developed a manufacturing process. In 1904, it was taken up at Westeregeln, close to Magdeburg, central Germany, but proved uneconomic. Following improvements to the furnaces, the Deutsche Karbid Gesellschaft was founded on 31 May 1906 in Frankfurt am Main by Metallgesellschaft. A factory was erected at Knapsack, near Cologne. It began operating, with three furnaces, in October 1907, using purchased carbide. A brown coal power plant and calcium carbide production facility were added in 1908. Several difficulties were encountered, including with the supply of labour; the conditions were hardly salubrious and the work arduous. In 1909, along with reorganization, the name of the company was changed to Aktiengesellschaft für Stickstoffdünger, and in the following year Krauss took over as manager. In 1911, the Knapsack site began the manufacture of calcium cyanamide in a continuous process.

Operation of the Frank-Caro process within Germany was delayed until 1908, when Frank and Caro came to an arrangement with Polzenius over the latter's cyanamide patent. From then on, addition of catalyst enabled a lowering of the operating temperature in all the furnaces that used the Frank-Caro process. Unlike the arc processes, the cyanamide process required pure nitrogen; the Frank-Caro cyanamide works were the first bulk customers for nitrogen obtained by fractionation of air according to the Carl von Linde process (1908).

On 6 November 1908, the Cyanidgesellschaft, with the backing of Deutsche Bank, created a subsidiary, Bayrische Stickstoffwerke AG, in Munich, for the manufacture of the lime-nitrogen, Kalkstickstoff, in Germany. (Degussa had withdrawn from the partnership; in 1899 its research chemist Johannes Pflieger [1867-1957] improved on the cyanide process developed by Hamilton Y. Castner.) Adolph Frank and Nikodem Caro were the principals of Bayrische. Albert Frank worked in administration until 1916, when following the death of his father he joined the board. A large factory was built at Trostberg, Bavaria, supplied with electricity from a hydroelectric power station on the River Alz, a tributary of the Inn ("Trostberg: From Fertilizers to Construction Chemicals"). The hygroscopic catalyst calcium chloride was later replaced with, for example, calcium fluoride, as well as other alkali and alkaline earth salts.

By 1914, annual global production of cyanamide was 120,000 tons, with one-quarter manufactured in Germany. The crude product containing approximately twenty-three per cent of nitrogen was applied direct to the soil as fertilizer. Most production in Germany came from the Bayrische factory. Many improvements in the manufacturing process were made during World War I. By the end of hostilities production increased over twenty-fold, as compared with 1914.

Carl Bosch

The challenge posed by producing synthetic fixed nitrogen as fertilizer was taken up using different routes, including the electric arc, at BASF, the leading dye manufacturing firm. BASF was founded one-hundred-and-fifty years ago, in 1865, at Mannheim, but soon after moved to nearby Ludwigshafen, on the west bank of the River Rhine. By 1900, the firm was seeking ways to diversify. The most difficult challenge, offering substantial profits if successful, was the fixation of atmospheric nitrogen. Particular interest was shown in the combination of hydrogen and nitrogen to produce ammonia, as achieved by physical chemist Wilhelm Ostwald (1853-1932).

On 12 March 1900, Ostwald advised the BASF management that he had devised a method for preparing ammonia from its elements based on the application of elevated temperature in the presence of an iron wire catalyst (Stoltzenberg 2004, p. 80). However, when the method was tried at BASF it was found that the ammonia was not formed directly (but perhaps from iron nitride). The scientist in charge of the evaluation was Carl Bosch.

Carl Bosch (1874-1940), was born in Cologne, where his father had a gas supply engineering business. In 1893, he embarked on an apprenticeship in a metallurgical factory, and during 1894-1896 studied metallurgy and mechanical engineering at the Technische Hochschule Charlottenberg. In 1896, he undertook research in chemistry at the University of Leipzig. In 1898, he was awarded his doctorate in organic chemistry under Johannes Wislicenus (1835-1902) (Holdermann 1953).

Bosch joined BASF in April 1899, working in the Indigo Department with Rudolf Knietsch. Around 1900 he was assigned the problem of nitrogen fixation; it was here that he quickly showed why Ostwald's ammonia process was flawed. From 1902, Bosch investigated metal cyanides and nitrides as possible sources of stable nitrogen products. Though a pilot plant for barium cyanide was erected in 1907, it was not viable commercially and was abandoned in 1908.

Fritz Haber

Fritz Haber (1868-1934) was born into a secular Jewish family, at Breslau, Prussia (now Wrocław, western Poland). He graduated *cum laude* at the Technische Hochschule Charlottenberg in 1891 with a doctoral thesis on an indigo derivative. However, aromatic organic chemistry was a little too much like cookery for the ambitious Haber. Following his academic studies, there followed short sojourns in industry at a Hungarian alcohol distillery, an Austrian Solvay factory, and a Polish salt mine, and then a semester during 1892 at the chemical institute of the Zurich's Eidgenossische Technische Hochschule (ETH), under Georg Lunge (1839-1923), former industrial chemist and a leading expert on gas analysis.

Haber then entered into his father's chemicals business, until, soon after, a poor decision - the late purchase of a large amount of chloride of lime intended to help bring an end to the 1892 cholera epidemic in Hamburg that, as a result of poor hygiene and contaminated water, took the lives of almost nine thousand people - brought his commercial career to a quick end.

Haber then joined the University of Jena as assistant to organic chemist Ludwig Knorr (1859-1921). However, Haber's interests were now moving towards the emerging field of physical chemistry, stimulated in part by the lectures of theoretical physicist Rudolf Straube. It was Haber's intention to work with Ostwald, though this did not work out. Meantime, in his mid-twenties, he underwent conversion to Christianity, an act, he hoped, that would improve his career prospects in the German Reich.

In 1894, Knorr gave Haber a letter of recommendation to Carl Engler (1842-1925) at the Karlsruhe Technische Hochschule. The attraction was probably Engler's interest from the mid-1880s in petroleum technology (Schuster 1976, pp.108-127). Haber joined Engler's institute as a research assistant in fuel technology, working with Hans Bunte (1848-1925). In 1896 Haber received his *Habilitation*, on the decomposition and combustion of hydrocarbons, and became a *Privatdozent*. There was soon after great interest in the new field of electrochemistry. In 1898, he published *Grundriss der Technischen Elektrochemie auf theoretischer Grundlage* (Outline of Technical Electrochemistry on a Theoretical Basis), and was appointed professor extraordinarius. His research increasingly involved thermodynamics and reactions in the gaseous phase.

Nitrogen Fixation: Haber's Methods

Haber's entry into the field of nitrogen fixation began in 1904 when he was asked by the Margulies brothers, Otto and Robert, of the Österreichische Chemische Werke, based in Vienna, to investigate conditions for the combination of atmospheric nitrogen with oxygen, using electric arcs, or directly with hydrogen to afford ammonia. Working at Karlsruhe with Gabriel van Oordt and applying high temperatures to the reaction between nitrogen and hydrogen, it was found that at normal pressure in the presence of catalysts the yield represented just a trace of ammonia, far too low to suit industrial application. Haber's *Thermodynamik technischer Gasreaktionen*, published in 1905, included details of ammonia experiments undertaken for the Margulies brothers (an English language version, *Thermodynamics of Technical Gas Reactions*, was published in 1908). It appeared to Haber in 1905 that the electric arc methods held out the greatest hope for capturing nitrogen.

In 1906, Haber, then aged thirty-eight, was appointed professor at Karlsruhe. Also in 1906, physical chemist Walther Nernst (1864-1941) developed his heat theorem, which enabled calculation of yield from thermochemical data. Nernst claimed that Haber's reported 0.005 per cent yield of ammonia, at 1,000°C with an iron catalyst at atmospheric pressure, was larger than that predicted by the heat theorem. Nernst, applying his new theorem, began an attack on Haber's findings related to the ammonia synthesis. Nernst had applied pressure in his experiments and managed to synthesize ammonia from its elements in a ceramic apparatus (Dronsfield and Morris, 2007). This spurred Haber to resort to experiments under pressure, starting at around 30 atmospheres, and in so doing he confirmed that his earlier results were correct.

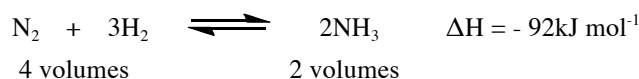

Since the reaction is exothermic, lowering the temperature might appear to be an important factor in encouraging formation of product ammonia. However, at a low temperature the rate at which the reaction takes place is extremely slow, as Haber had found in his early experiments. To bring about the rapid formation of ammonia a high temperature is required, although this in turn causes decomposition of the ammonia to the starting hydrogen and nitrogen. The use of high pressure and elevated temperature act in opposition in this particular process. The way to reduce the barrier to reaction, as was known, was to introduce a catalyst. Also, the decomposition of ammonia was minimized by its rapid withdrawal.

Henri Le Châtelier, aware that a compromise between the rate of reaction and the yield of ammonia could be obtained by adjusting the pressure and temperature and introducing a catalyst, had in 1900 investigated the synthesis of ammonia under such conditions. In 1901 he filed a patent for the process. Further development was brought to an abrupt halt when the apparatus blew up. It was left to Fritz Haber to take up the ammonia story where Le Châtelier and Ostwald had left off.

Haber's work was followed closely by Engler, who had joined the board of BASF in 1903, at the time when Carl Bosch was investigating the fixation of atmospheric nitrogen by indirect cyanide and metal nitride routes. The BASF experimental work was carried out in the Inorganic Department by Alwin Mittasch (1869-1953), who joined the firm in 1904. Mittasch received his doctorate in 1901, at Wilhelm Ostwald's institute in Leipzig, under the supervision of Max Bodenstein (1871-1942) (Holdermann 1953).

On 16 February 1908, Engler recommended Haber to BASF as an expert in nitrogen fixation, particularly for his work on the formation of nitric oxide using electrical discharges, based on studies carried out jointly with Adolf Koenig at Karlsruhe (Schuster 1976, pp. 124-125). BASF Central Research Laboratory director August Bernthsen (1855-1931) visited Haber at Karlsruhe on 6 March 1908, as a result of which two research contracts were drawn up (Schuster 1976, pp. 124-125; Smil 2001, pp. 75-82). Koenig joined BASF, where he continued to investigate the electric arc method, and collaborated with Haber. Haber in 1909 filed his first patent for the direct fixation of nitrogen, based on the electrothermal reaction.

Until the summer of 1909, this was still the most favoured route to nitrogen fixation, as was made clear in London at the Seventh International Congress of Applied Chemistry, formally opened on May 27 by the Prince of Wales (Later King George V) at the Royal Albert Hall. The papers on electrothermal methods for the capture of nitrogen, chaired by William Ramsay (1852-1916), attracted good audiences, reflecting their significance to the new artificial fertilizer industry. Present were Kristian Birkeland, Samuel Eyde, Nikodem Caro, BASF research leader August Bernthsen, Otto N. Witt, and Russian high-pressure chemist Vladimir Ipatieff. Certainly this was the largest ever gathering of inventors and representatives of major electrothermal methods then in use for capturing nitrogen, including the cyanamide route. Birkeland reviewed progress in the application of his furnace. Bernthsen described the long tubular Schönherr furnace in which BASF held high hopes. On the same occasion he disparaged the calcium cyanamide product.

By then, however, Haber was on the point of achieving success in another direction, the high-pressure synthesis of ammonia from its elements (Tamaru 1991).

The 1908 agreement between BASF and Haber included further investigation of the direct combination of nitrogen with hydrogen. It was perhaps fortunate that Nernst's attacks on Haber's earlier results stimulated a completely new approach, based on the application of pressure. Unlike Nernst, Haber opted for an apparatus made of steel.

Haber's response relied on the dexterity of his young English research assistant, Robert Le Rossignol (1884-1976), recently arrived from Ramsay's laboratory at University College London. Le Rossignol, the son of a physician from St Helier, Jersey, in the Channel Islands, had achieved excellent results in the basement laboratories at University College, a far cry from the great comforts and conveniences of a modern German research institute. In 1907, Ramsay had recommended research under Richard Abegg at Breslau, but Le Rossignol opted for Haber's laboratory because he had heard that there were already "too many Englishmen" at Breslau. Haber was greatly impressed by his newcomer's efforts, especially after Le Rossignol confirmed the results of earlier work on the synthesis of ammonia. Haber's calculations suggested that an estimated eight per cent equilibrium yield of ammonia could be achieved at 600°C and 200 atmospheres. This was now Le Rossignol's assignment, using custom made steel apparatus and a novel compressor newly acquired by Haber that was capable of achieving a pressure of 200 atmospheres. Critical to the enterprise was the help of the laboratory technician Friedrich Kirchenbauer.

Le Rossignol succeeded magnificently, all the time introducing improvements into what was designed as a continuous process. His first major contribution was a special valve, later called the Le Rossignol valve, which withstood the high pressure and controlled the flow of hot gases.

By introducing a manganese catalyst, and carrying out the reaction at 200 atmospheres and in excess of 700°C, an increase in the rate of conversion was observed. Catalysts based on iron, chromium, and nickel were also tried. There was little enhancement until osmium, and uranium, as uranium carbide, were investigated as catalysts. Osmium was found to be the most effective. This rare and valuable metal was received with the help of the industrialist Leopold Koppel, for whom Haber acted as a scientific consultant. Haber's services were mainly to Koppel's Auer-Gesellschaft, founded in 1892 as successor to Deutsche Gaslicht Glühlicht AG.

Le Rossignol designed the complete ammonia apparatus, in which the compressed mixture of reactant gases was directed through the steel converter, the mixture was then cooled, the ammonia liquefied, and separated from unreacted

gases. After its performance was deemed satisfactory, Haber advised Engler: “Es tropft, Herr Geheimrat!” (Schuster 1976, p. 126).

This was enough to encourage further investigation aimed at technical application. Haber and Le Rossignol had to devise an apparatus capable of withstanding the high pressure and temperature requirements. Elegant innovations included pre-heating of the reactant gases by the outgoing reaction mixture while still in the converter, and the recirculation of unreacted gases. The low yield required, for industrial application, a continuous process from which product ammonia could be separated, and fresh charges of preheated hydrogen and nitrogen introduced. The small-scale bench top demonstration apparatus was less than one metre high (**Figure 3**).

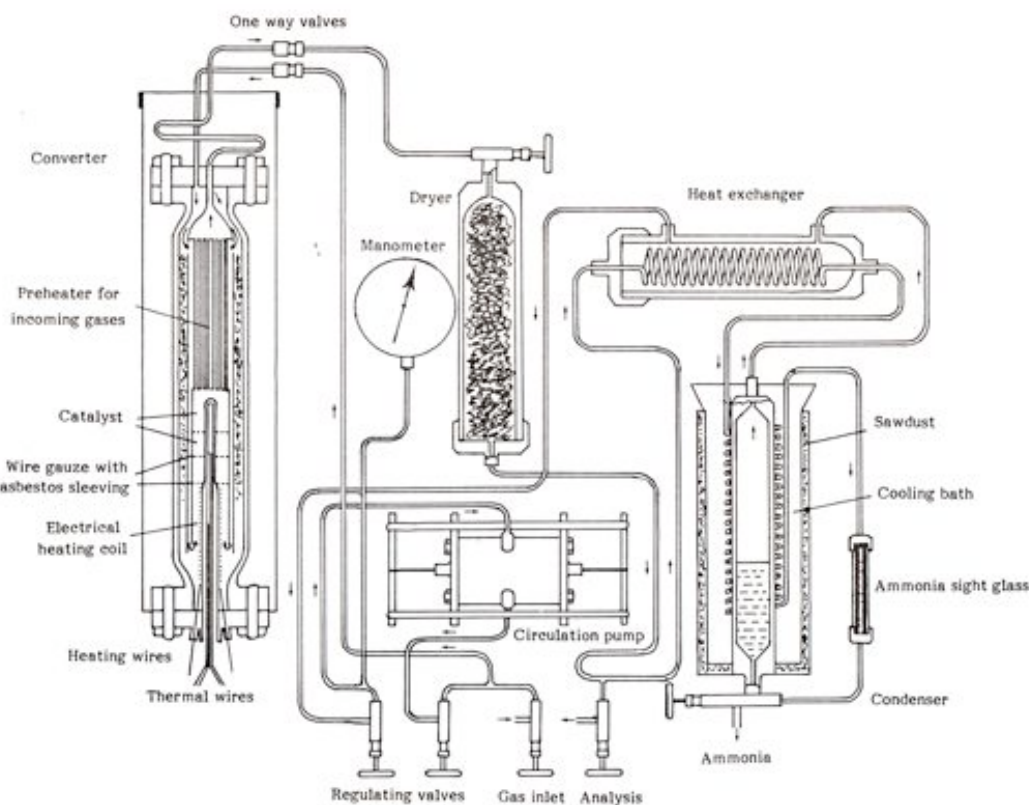

Figure 3: Haber-Le Rossignol Laboratory Apparatus for Synthetic Ammonia (Travis, 1984)

The heat removed from the exhaust gases, it was realized, could be used to maintain the continuous operation. There was a further advantage; the process, if viable on a manufacturing scale, and unlike the electric arc and cyanamide processes, did not require enormous quantities of electricity. It also provided a cleaner product than the cyanamide process (Haber and Le Rossignol 1913).

Scaling Up

Bosch, as BASF nitrogen-fixation specialist, was invited to observe Haber’s apparatus in operation at Karlsruhe. According to one version of events, on 1 July 1909, Bosch, Mittasch and BASF chief mechanic Kranz turned up at Haber’s laboratory. The first demonstration run was hardly auspicious. A bolt of one of Le Rossignol’s carefully made seals sprang under the great pressure. The circulating pump was shut down, and repairs put in hand. Bosch was unable to wait and returned to Ludwigshafen. Mittasch and Kranz remained until the seal was put right, and the next day liquefied ammonia began to appear. Mittasch’s report impressed Bosch who advised his colleagues. At first, August Bernthsen was not so impressed and remained committed to the electrothermal process.

However, after much discussion in the boardroom, BASF decided to adopt Haber’s method. For the early experimental work, around 100g of osmium was purchased, probably at the time most of the world supply of the hard, bluish-white metal. Mittasch was assigned the challenge of developing an inexpensive and effective catalyst, one that would make the method commercially viable. Mittasch’s colleague George Stern devised a laboratory air-cooled apparatus for testing catalysts, around two grams at each run, under pressure, with internal heating. Twenty-four identical experimental units were manufactured. After over two thousand screening experiments, it was found that iron, activated by the presence of a promoter, and as first investigated in 1910, was an ideal catalyst (Mittasch 1950, 1951).

No less problematic were the metallurgical and engineering challenges. Bosch worked on the design of a pilot plant, aided by chief engineer Franz Lappe. They had to construct a converter suited to continuous operation under conditions of high pressure and high temperature. The special Mannesmann tubes burst, believed at first to be the result of embrittlement by nitrogen. Bosch used his training in metallographic research to establish the cause. At high pressure, it was found, hydrogen diffused into the iron of the steel wall, causing it to become brittle, the result of decarbonization.

The converter had to be re-designed to prevent, or at least minimize, this difficulty. The development work continued with experimental converters encased in concrete, minimizing damage to the surroundings from the inevitable explosions. In February 1911, Bosch, aided by Lappe, overcame the problem by developing a double-wall converter. The inner wall, of soft iron, or low carbon steel, which did not undergo decarbonization, allowed hydrogen to diffuse through it, with rapid loss of pressure, under which conditions the outer wall, of ordinary steel, did not become brittle. This was aided by narrow grooves machined on the outside of the inner wall as the tube was turned. Small holes in the outer wall enabled the release of hydrogen (Figure 4). Massive gas compressors of a type never previously used in industry had to be designed. Tests carried out on 5 March 1911 with a 4-metre high converter were considered sufficiently successful for the commissioning of a full-size manufacturing unit (Appl 1982).

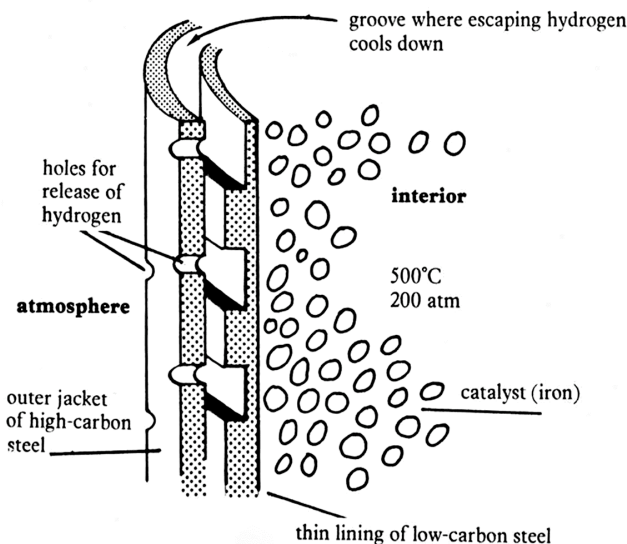

Figure 4: Diagram, much simplified, of Bosch Double-wall Converter for Synthetic Ammonia (author)

Nitrogen was at first obtained by Linde's process for the liquefaction of air. Hydrogen for the pilot plant came from the electrolysis of brine. For full-scale production, hydrogen was made from the water gas process. The equipment, including compressors, and eight-metre high-pressure converters, was put together at the new Oppau facility, three kilometres north of the Ludwigshafen factory. A dedicated Ammonia Laboratory headed by Mittasch served the new Nitrogen Department. Production of synthetic ammonia began on 9 September 1913 at the rate of twenty tons per day, soon increased to thirty tons (Figure 5). The ammonia was converted into ammonium sulphate for use as fertilizer.

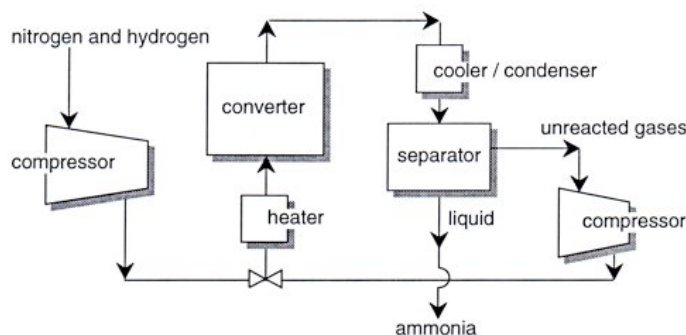

Figure 5: Flow Chart for Manufacture of Ammonia (Travis, 1998)

Now a new source of stable synthetic nitrogen fertilizer was added to cyanamide, the products from electric arc processes, gasworks ammonia, and, most importantly, imported Chilean nitrate, which was still the most economical source for nitric acid production. Nevertheless, German hopes for self-sufficiency in nitrogen products had come a giant step closer. Carl Bosch had stretched available technology to the limit and succeeded.

Meantime, in 1911, Haber, now a leading physical chemist, noted for his ingenuity and organizational skills, and supported by Koppel, was appointed head of the new Kaiser-Wilhelm-Institut für physikalische Chemie und Electrochemie in Berlin, which opened in 1912.

Nitric Acid

Production of ammonia by fixation of nitrogen was a triumph. For many purposes, however, particularly in the manufacture of explosives, the ammonia required conversion to concentrated nitric acid.

This was another difficult technical challenge that had to be overcome. In 1908 the first large plant for catalyzed air oxidation of ammonia to nitric acid was constructed by the Gewerkschaft des Steinkohlenbirgwerks Lothringen. The

ammonia came from a coke-oven plant at Gerthe, in Westfalen (Westphalia; Gerthe gave its name to the plant), near Bochum in the Ruhr. This relied on Wilhelm Ostwald's method, developed at Leipzig with Eberhard Brauer, his future son-in-law, during 1900-1901, using platinum, either solid or spongy, as a catalyst, for which a patent had been filed in 1902. Difficulties were encountered due to the impermeability of the platinum. Nevertheless, the output of nitric acid from ammonia at Gerthe, based on Ostwald's work, in 1911 reached 1,495 tons (Travis 1984, p. 50).

At Bayrische, Nikodem Caro worked on the catalytic conversion of cyanamide-derived ammonia to nitric acid using thorium compounds as catalysts at atmospheric pressure. In 1907, Caro and Albert Frank collaborated with the engineering firm Berlin-Anhaltische Maschinenbau AG (Bamag), on small-scale ammonia oxidation using platinum as catalyst. Special tanks were designed for bulk transportation of the acid.

During 1914, Caro and Frank filed patents for the oxidation of ammonia with an electrically heated platinum gauze catalyst. They also developed an improved apparatus for the oxidation of ammonia. This work offered an improvement over Ostwald's corrugated platinum strip that had a lifetime of four to six weeks (Hunt 1958, p. 133). Severe corrosion problems in the absorption areas still had to be overcome. Despite considerable success, under normal economic conditions this could not provide the basis for replacing even in a small way the manufacture of nitric acid from Chilean nitrate. But this was not the case in a situation of war emergency.

Synthetic ammonia, and oxidation of ammonia to nitric acid, might well have remained no more important than many other novel industrial processes that were appearing during the first decade of the twentieth century but for a world-shattering event: the assassination of Archduke Franz Ferdinand of Austria-Este, eldest son of Archduke Karl Ludwig, and heir presumptive to Franz Josef and the Austro-Hungarian Empire, and his wife, at Sarajevo on 28 June 1914. On 28 July there was the first declaration of what was to become the "All-Europe Conflict", or Great War. Until then there had been no general mobilization of industry for war. Oppau was producing synthetic ammonia, by what had become known as the Haber-Bosch process, for conversion to fertilizer. Hugo Wolff at BASF had examined metals of the platinum group as catalysts for oxidation of the ammonia. Studies on nitrogen fixation and oxidation to nitric acid were conducted at Bayer, and the Hoechst dyeworks (Meister, Lucius & Brüning). They were about to receive priority.

War and Peace

The challenges of nitrogen fixation, and their implications, had been expressed in no uncertain terms during the summer of 1903 by Ostwald, writing in the *Schwäbische Merkur*. "The significance for bound nitrogen...is especially high for both war and peace...Without saltpetre the best military is almost helpless...Were war to break out today between two great powers, one of which was able to prevent the export of saltpetre from Chile's few harbours, that ability alone would render its opponent almost incapable of fighting" (quoted from Stoltzenberg 2004, p. 130). Therein lay the nitrate problem. Its solution was a strategic necessity, quite apart from the critical importance to agriculture.

This was also recognized in Britain, where inventor Ernest Kilburn Scott, before the British Association for the Advancement of Science in 1911, and the Royal Society of Arts in 1912, made similar statements in support of the need for developing technical methods of nitrogen fixation. Kilburn-Scott was working on his 3-phase a.c. electric arc process, for which a laboratory-scale apparatus had been assembled at Northampton Polytechnic Institute, Clerkenwell, London (Kilburn Scott 1915).

Nitrogen Chemistry at War

In August 1914, the German plan of attack, the Schlieffen plan, was aimed at the rapid surrender of Paris and capitulation of France, while Russia was held at bay by a small force. Anticipating a German victory, several leading scientists and scholars, in fits of extreme, if misguided, patriotism, volunteered for service at the front. They included Walther Nernst and the sociologist Alfred Weber. Reality soon set in. The Schlieffen plan failed during the first two weeks of September 1914 at the banks of the River Marne. The intellectuals returned to their institutions. This foreshadowed the years of extended trench warfare along a front that extended from Dunkirk to Switzerland.

The German army, and navy, had now to grapple with the ramifications. To maintain military strength, new strategies had to be called into play, particularly for the supply of the matériel of war, not least of which were aromatic nitro compounds, for explosives. The availability of nitro compounds in turn relied on adequate supplies of nitric acid, and science-based chemical industry. Nitrogen products came to the fore. The Germans were fortunate, for a while, in that a substantial amount of Chilean saltpetre, in excess of 20,000 tons, had been abandoned by the retreating Belgian army at Antwerp, while stocks were held by various companies in Germany. But these were hardly adequate for meeting the demands of prolonged warfare. The military leaders needed to be made aware of the situation.

On 13 August 1914, Walther Rathenau (1867-1922), of the electrical corporation AEG, was placed in charge of the War Raw Materials Office (Kriegsrohstoffabteilung) by the Prussian War Minister Erich H. Falkenhayn. In September, organic chemist Emil Fischer (1852-1919) reviewed the nitrogen situation for Rathenau's office. It was realized that Chilean saltpetre could not satisfy all of Germany's needs, particularly if the stalemate was to continue. Fischer, in his report of 1 October, recommended adoption on a large scale of the Haber-Bosch process, and conversion of the ammonia to nitric acid by a method that was far from technically perfect. Fritz Haber and Emil Fischer together warned of the impending crisis in nitric acid supply. Rathenau, with the support of Haber, arranged for Carl Bosch to meet with representatives of the War Ministry in Berlin to discuss the nitrogen situation. Bosch was struck by the ignorance of basic scientific and technical knowledge among senior military personnel. He had to describe the various processes involved in the production of conventional high explosives, the aromatic nitro compounds, in particular the need for nitric acid, which mainly relied upon the nitrates imported from Chile.

Fischer, as a member of the War Ministry's Commission for the Preparation of Contracts for the Purpose of Increasing Nitrogen Production (Kommission zu Vorbereitung der Verträge zwecks Steigerung der Stickstoffproduktion), pushed forward the commissioning of new nitrogen facilities in the chemical industry. On 30 September 1914, a Reich war chemical corporation, the Kriegsschemikalien AG, one of several large government supervised corporations established to ensure adequate supplies of war materials, was founded. Bosch was present at the first meeting and was asked to increase the BASF output of ammonia. The challenge remained of converting ammonia to nitric acid suited to the manufacture of explosives. Bosch had even been encouraged by Fischer to start adding capacity to the Oppau facility before contracts with the War Ministry had been finalized (Moy 1989, pp. 110-113).

Wilhelm Ostwald and Eberhard Brauer, as well as the coal industry, favoured the nitric acid process adopted at Gerthe, for which they acted as consultants. The owners of Gerthe promised Fischer that they could build twenty plants with an output of 6,000 tons of sodium nitrate from coal gas ammonia every month. Fischer also considered the electric arc processes, including that of Pauling. BASF had already, in 1911, dropped its interest in the Schönherr furnace, convinced that the Haber method would lead to the decline of all the electrothermal methods (Szöllösi-Janze 2000, pp. 98-99; Mantell 1940, pp. 574-575).

Prior to the summer of 1914, Chilean nitrate and gas works ammonia were by far the major sources of nitrogen. According to a German account, appearing in the *Frankfurter Zeitung*, on 23 November 1919, nitrogen consumption by Germany in 1913 was made up as follows: Chilean saltpetre, 750,000 tons (of which the nitrogen content was 116,000 tons); ammonium sulphate, from gas works, 460,000 tons (nitrogen 92,000 tons); Norwegian nitrate, from the Norsk Hydro processes, 35,000 tons (nitrogen 4,500 tons); calcium cyanamide, 30,000 tons (nitrogen 6,000 tons); and Haber-Bosch derived ammonium sulphate, 20,000 tons (nitrogen 4,000 tons). The total, calculated as nitrogen, was 222,500 tons (LeFebure 1923, p. 38). In 1913, the monthly output of the Haber-Bosch process at Oppau was, according to one account, 600 tons of ammonia, converted into 3,000 tons of ammonium sulphate, a rate that was probably increased by the autumn of 1914. The press report certainly emphasized the overriding importance of Chilean nitrate as compared with other sources. Germany had since the turn of the century been the main importer, mainly for the agricultural sector.

The military needs in explosives were now calculated to be 12,000 or more tons per month. Certainly the uninterrupted supply of nitrates from Chile might have seemed secure, though it could not be guaranteed. It depended on the tide of war at sea, which was changing. In September, the Germans won advantages in commerce-raiding and submarine operations. On 1 November 1914, a British Royal Navy squadron off the Chilean coastal city of Coronel in the South Pacific Ocean suffered defeat in a duel with the German East Asia Squadron, commanded by Count von Spee. The situation was reversed on 8 December 1914, at the Battle of the Falkland Islands, when Spee went down with his flagship, the *Scharnhorst*. From then until the end of the war the direct supply of Chilean saltpetre was cut off from Germany by the Royal Navy's blockade. The Allies continued to be hampered at sea, including by an intensive programme of submarine attacks between late February and mid-May 1915, and particularly during 1916 and 1917, but they were not denied access to nitrate.

Although obliged to deal with all the nitrogen firms, Haber, as a government officer of the Reich engaged in procuring essential chemicals, certainly favoured BASF, whose chemists and engineers were working on a commercially feasible means for obtaining concentrated nitric acid from the Haber-Bosch ammonia facility at Oppau. On behalf of the Reich he came to an agreement with BASF, finalized in January 1915, for a massive expansion of ammonia production, backed by a state subsidy of six million marks. Shortly after, Haber became deeply involved in the German gas warfare programme (Haber 1986).

With the outbreak of war Robert Le Rossignol, as an enemy alien living in Germany, was interned. While at Karlsruhe he had married a local girl and they moved to Berlin where, on Haber's recommendation, in 1909 he joined the laboratories of the Auer-Gesellschaft, manufacturer of Osram lamps. Haber intervened and arranged Le Rossignol's release in 1915. He then returned to the laboratories of the Auer-Gesellschaft. Le Rossignol left Germany for England on 6 December 1918. In 1919, he joined the Hammersmith (London) laboratories of the British Osram Company Ltd., a company confiscated as enemy property, and which from 1916 was wholly owned by the (British) General Electric Company. From 1923, General Electric research was carried out at purpose-built laboratories in Wembley. There, Le Rossignol developed large high-powered transmitting valves for radio communication.

Shortly after the outbreak of war in 1914, Nikodem Caro negotiated with Emil Fischer for additional electrical power for use in the Bayrische (Troostberg) cyanamide works, in particular for meeting the needs of the agricultural sector. Cyanamide factories were well established and the process perfected. Moreover, not only had conversion of cyanamide to ammonia been achieved, but oxidation of the ammonia had been integrated into the Bayrische factory. After Caro agreed to increase production of cyanamide at least fourfold, the Reich Treasury, with Rathenau's backing, on 5 March 1915, commissioned Bayrische to erect new cyanamide production facilities.

Hoechst had acquired almost half the shares in the Knapsack cyanamide facility by December 1914, and as a result had priority over the supply of cyanamide, for conversion into ammonia. Hoechst expanded the Knapsack facility in 1915. New carbide furnaces were installed, and the workforce was increased from sixty to four hundred.

Ammonia Oxidation

The study of the ammonia oxidation process had been taken up by both the Hoechst dyeworks and BASF by around 1912 or 1913. At the start of the war, Hoechst was the major producer of concentrated nitric acid, based increasingly on the oxidation of ammonia from cyanamide, with an output of 150 tons of 100 per cent acid every day. The development of ammonia oxidation from synthetic nitrogen compounds became a priority from late 1914. BASF, now fully involved

with the Haber-Bosch process, had not been idle. Alwin Mittasch worked on improvements to the oxidation since early 1914. In July, in collaboration with Christoph Beck, he came up with an iron oxide catalyst containing a promoter. An efficient iron-bismuth catalyst was also discovered. This was important, since there were shortages of platinum, previously available from the Ural Mountains in Russia. It was Mittasch's success which enabled Carl Bosch in October 1914 to guarantee that new enlarged plant at Oppau would meet the needs of the BASF contract with the military from around March or April 1915 (Stoltzenberg 2004, p. 131).

Converting ammonia to nitric acid involved the oxidation of ammonia, of seven to ten per cent volume, mixed with air to give nitric oxide.

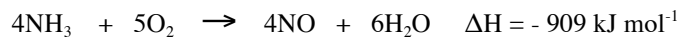

The oxide was then combined with oxygen:



The dioxide was absorbed in water to afford dilute nitric acid, not unlike similar steps in the electric arc processes, and concentrated.

In May 1915, BASF began production of the concentrated nitric acid. By 1918, BASF nitric acid output was 140 tons of 100 per cent acid every day, from Oppau and Ludwigshafen (Hartley 1919, 211). While this was considerably less than the 375 tons produced by Hoechst (which in part relied on Oppau ammonia), BASF manufacture, based on Haber-Bosch ammonia, and its oxidation, would become the route of choice. Nevertheless, at this stage and for some time after, German munitions production was heavily reliant on the cyanamide works. In 1916, the War Ministry authorized further expansion at Knapsack, resulting in a new cyanamide facility capable of producing additional ammonia that Hoechst required for conversion into concentrated nitric acid. As catalyst, Hoechst used platinized asbestos, diaphragms of platinum, or a narrow tube of platinum.

During the first years of the war nitrogen was prepared at Oppau by blowing air over coke to form a mixture of carbon monoxide and nitrogen, that is, producer gas. Later a mixture of nitrogen and hydrogen in the proportions required by the ammonia synthesis was made up from producer gas, water gas and steam. The mixed gases were temporarily freed of nitrogen, and the carbon monoxide was oxidized with steam by the "shift reaction". The gases were washed to remove impurities and the hydrogen and nitrogen made up to the correct stoichiometric proportions, a mixture of composition seventy-five per cent hydrogen and twenty-five per cent nitrogen (Appl 1982). Further expansion at Oppau enabled daily production of ammonia to approach the peak of 250 tons, or 90,000 tons a year, by the beginning of 1917.

The wartime emergency and organization of a new sector of the chemical industry in Germany based on ammonia and nitric acid was the outcome of outstanding research efforts and commitments. It involved not only close integration between the activities of laboratory, pilot plant and construction departments, but also negotiations with the state and its military arm, and substantial support from the Reich treasury (Johnson 2004, pp. 142-171).

Leuna

On the basis of the success of the Oppau ammonia works, Bosch lobbied the German government to provide funding for the construction of a new Haber-Bosch facility, to the east, in central Germany, at Leuna, near Merseburg, and south east of Halle. Not only was it safe from the frequent Allied bombing (the French had first bombed Oppau on 27 May 1915), but nearby were sources of water, brown coal and gypsum. It was also in Prussia, rather than in Bavaria.

An agreement was reached in April 1916. BASF accepted the cost of construction, with subsidies from the Reich for the war work. Construction commenced on 19 May 1916 (Morris 1982, p. 15). When on 18 August 1916, the two groups of major German dye making firms created the Interessengemeinschaft der deutschen Teerfarbenindustrie (I.G. Farben), which included Weiler-ter Meer and Griesheim-Elektron, one of the areas excluded from their joint interests was the BASF involvement in ammonia.

The year 1916 was critical in the conduct of the war. Germany launched the Verdun offensive in February, leading to a series of attacks and counter attacks until December. On 1 July 1916, the British began their massive Somme attack, a major setback for the Germans, who were forced to move men and equipment from the Verdun sector. At the end of August, Paul von Hindenburg and Erich von Ludendorff, following their military successes on the Eastern Front since 1914, were appointed joint chiefs-of-staff, replacing Erich von Falkenhayn whose Verdun offensive was falling apart.

Soon after, the Hindenburg programme for industrial reorganization, named after the elderly new chief of staff, and in which Carl Duisberg of Bayer played a prominent role, was implemented. The programme involved an industrialized war economy carried out on an unprecedented scale, with centralized control of the production of armaments, particularly shells and explosives. It called for urgent doubling and even tripling of war production. This meant increased production of ammonia, calcium cyanamide, nitric acid, ammonium nitrate, and toluene and other aromatics, as well as the war gases.

The new Leuna ammonia facility was well suited to the demands of the Hindenburg programme. On 27 April 1917, the factory dispatched its first railway tank wagons containing liquid ammonia. It was just three weeks after the United States declared war on Germany.

The initial plant capacity at Leuna was 36,000 tons per year. This was soon increased, in line with the demands of the Hindenburg programme, to 75,000 tons, then to a planned 160,000 tons. Not long before the cessation of hostilities there was a proposal for further expansion to 240,000 tons per year.

In April 1918, von Ludendorff, Supreme Commander of the German Army in Flanders, failed to hold back British forces on the coasts of Belgium and France. This decisive event would bring an end to the war. In the final stages, Germany was producing 650 tons of synthetic ammonia per day. Of this Oppau was responsible for 250 tons and Leuna for 400 tons (Hartley 1919, p. 211). German output of cyanamide, much of it converted into nitric acid for the manufacture of explosives, was close to an annual rate of 600,000 tons. Following the cessation of hostilities, it was estimated that there was the potential in Germany for peacetime manufacture of 500,000 tons of nitrogen products annually, as fertilizer: sixty per cent from the Haber-Bosch process, and twenty per cent each from the gas works and cyanamide factories (“Nitrogenous Fertilizers”, 1920). The future of the Haber-Bosch process had been assured by the needs of wartime.

Conclusion

The almost four-year stalemate that followed the Battle of the Marne in September 1914 made heavy demands on the producers of nitrogen compounds employed in the manufacture of explosives. At that time both the Allies and the Central Powers were reliant on imported Chilean nitrate for production of the nitric acid required to nitrate, mainly aromatic, organic chemicals. For the Central Powers the availability of this vital commodity ceased following the Battle of the Falkland Islands in December 1914. German industry turned to the processes for capturing atmospheric nitrogen that had developed from around 1900: the cyanamide and, increasingly, Haber-Bosch processes were of critical importance. This stimulated technical improvement and the massive expansion of these processes, as well as major developments in the production of concentrated nitric acid by catalytic oxidation of ammonia. The Haber-Bosch process came to the forefront from 1916 mainly as a result of the decision to erect a new works at Leuna, and the demands of the Hindenburg programme of state-led industrial organization. The war inaugurated a new era in industrial chemistry, including the growth of a key sector: nitrogen products as fertilizer (Smil 2001; Travis 1998).

An expanded version of this paper will appear in the Springer Briefs in Molecular Sciences: History of Chemistry series, edited by Seth C. Rasmussen

REFERENCES

- Appl, Max, “The Haber-Bosch Process and the Development of Chemical Engineering”, in *A Century of Chemical Engineering*, ed. W.F. Furter (New York: Plenum, 1982), 29-53.
- Crookes, William, *The Wheat Problem* (New York: G.P. Putnam’s Sons/London: John Murray, 1900).
- Dronsfeld, Alan T., and Peter J.T. Morris, “Who Really Discovered the Haber Process”, *Education in Chemistry*, May 2007. <http://www.rsc.org/Education/Eic/issues/2007May/WhoReallyDiscoveredHaberProcess.asp> (accessed 28 January 2015).
- Haber, Fritz, and Robert Le Rossignol, “Ammonia; Technical Preparation of...From its Elements”, *Journal of the Society of Chemical Industry*, 32, no. 3 (15 January 1913): 134-138.
- Haber, Lutz (L.F.), *The Poisonous Cloud: Chemical Warfare in the First World War* (Oxford: Oxford University Press, 1986).
- Hartley, H[arold], “Report of the British Mission Appointed to Visit Enemy Chemical Factories in the Occupied Zone Engaged in the Production of Munitions of War”, in *Dyestuffs: Hearings before the Committee on Ways and Means, House of Representatives, on H.R. 2706 and H.R. 6495, June 18-20 and July 14-18, 1919 [66th Cong., 1st Sess., 1919]*, Committee on Ways and Means (Washington: Government Printing Office, 1919), 210-214.
- Holdermann, Karl, *In Banne der Chemie: Carl Bosch, Leben und Werke* (Düsseldorf: Econ-Verlag, 1953).
- Hunt, L.B., “The Ammonia Oxidation Process for Nitric Acid Manufacture”, *Platinum Metals Review*, 2, no. 4 (1958): 129-134.
- Johnson, Jeffrey Allan, “The Power of Synthesis, 1900-1925”, in Werner Abelhauser, Wolfgang von Hippel, Jeffrey Allan Johnson, and Raymond G. Stokes, *German Industry and Global Enterprise. BASF: The History of a Company* (New York: Cambridge University Press, 2004), 115-206.
- Kilburn Scott, Ernest, “Production of Nitrates from Air, with Special Reference to a New Electric Furnace”, *Journal of the Society of Chemical Industry*, 34, no. 3 (15 February 1915): 113-126.
- LeFebure, Victor, *The Riddle of the Rhine: Chemical Strategy in Peace and War* (New York: E.P. Dutton & Co.), 1923.
- Lunge, Georg, *Handbuch der Schwefelsäurefabrikation und ihrer Nebenzweige*, 2 vols (Braunschweig: Friedr. Vieweg & Sohn, 1916).
- Mantell, C.L., *Industrial Electrochemistry* (New York: McGraw Hill, 2nd edition, 1940).
- Miles, Frank Douglas, *Nitric Acid: Manufacture and Uses* (London: Oxford University Press, 1961).
- Mittasch, Alwin, “Early Studies of Multi Component Catalysts”, in *Advances in Catalysis*, vol. 2, eds., W.G. Frankeburg, V.I. Komarewsky, and E.K. Rideal (New York: Academic Press, Inc., 1950), 81-104.
- Mittasch, Alwin, *Geschichte der Ammoniak-synthese* (Weinheim: Verlag Chemie, 1951).

- Morris, Peter J.T., "The Development of Acetylene Chemistry and Synthetic Rubber by I.G. Farbenindustrie Aktiengesellschaft: 1926-1945", D. Phil. Thesis, University of Oxford, 1982.
- Moy, Timothy D., "Emil Fischer as 'Chemical Mediator': Science, Industry and Government in World War One", *Ambix*, 36 (1989): 109-120.
- "Nitrogenous Fertilizers in Germany", *Journal of the Society of Chemical Industry*, 39, no. 3 (16 February 1920): 59R.
- Schuster, Curt, *Wissenschaft und Technik* (Ludwigshafen: BASF, 1976).
- Smil, Vaclav, *Enriching the Earth: Fritz Haber, Carl Bosch, and the Transformation of World Food Production* (Cambridge, Mass.: MIT Press, 2001).
- Stoltzenberg, Dietrich, *Fritz Haber: Chemist, Nobel Laureate, German, Jew* (Philadelphia: Chemical Heritage Foundation, 2004).
- Szöllösi-Janze, Margit, "Losing the War, but Gaining Ground: The German Chemical Industry during World War I", in *The German Chemical Industry in the Twentieth Century*, ed. John E. Lesch (Dordrecht: Kluwer, 2000), 91-121.
- Tamaru, Kenzi, "The History of the Development of the Ammonia Synthesis", in *Ammonia Synthesis: Fundamentals and Practice*, ed. J.R. Jennings (New York: Plenum, 1991), 1-18.
- Travis, Anthony S., *The High Pressure Chemists* (Wembley: Brent Schools and Industry Project, 1984).
- Travis, Anthony S., "High Pressure Industrial Chemistry: The First Steps, 1909-1913, and the Impact", in *Determinants in the Evolution of the European Chemical Industry, 1900-1939: New Technologies, Political Frameworks, Markets and Companies*, eds. Anthony S. Travis, Ernst Homburg, Harm Schröter, and Peter J.T. Morris (Dordrecht: Kluwer, 1998), 3-12.
- "Trostberg: From Fertilizers to Construction Chemicals", <http://history.evonik.com/sites/geschichte/en/predecessor-companies/skw-trostberg> (accessed 19 August 2014).
- Witt, Otto Nikolaus, *Das neue Technisch-Chemische Institut der Königlich-Technischen Hochschule zu Berlin und die Feier seiner Eröffnung am 25 Nov 1905* (Berlin: Weidmann, 1905).