

## Supporting Information

### Alternating-Current Driven Quantum-Dot Light-Emitting-Diodes with High Brightness

Fengtian Xia, Shuming Chen\*,

Department of Electrical and Electronic Engineering, Southern University of Science  
and Technology, Shenzhen, 518055, P. R. China

chen.sm@sustc.edu.cn

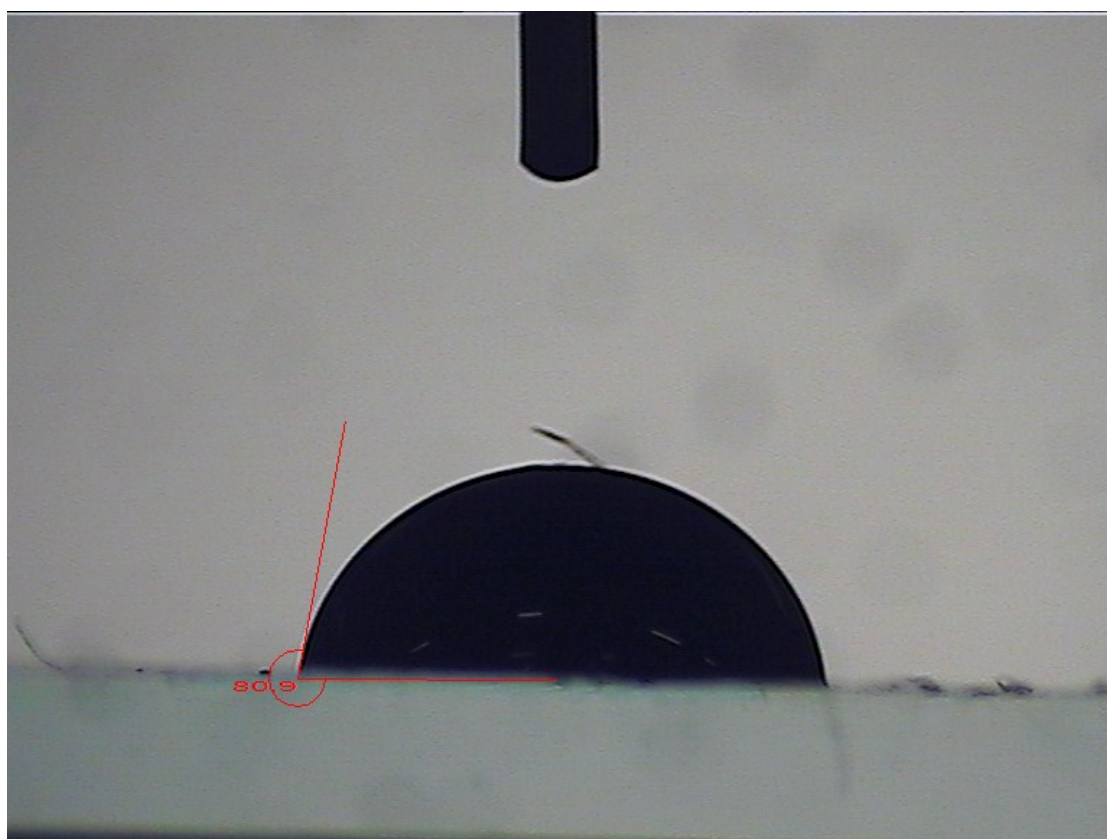

**Figure S1.** Contact angle of PEDOT:PSS deposited on P(VDF-TrFE-CFE).

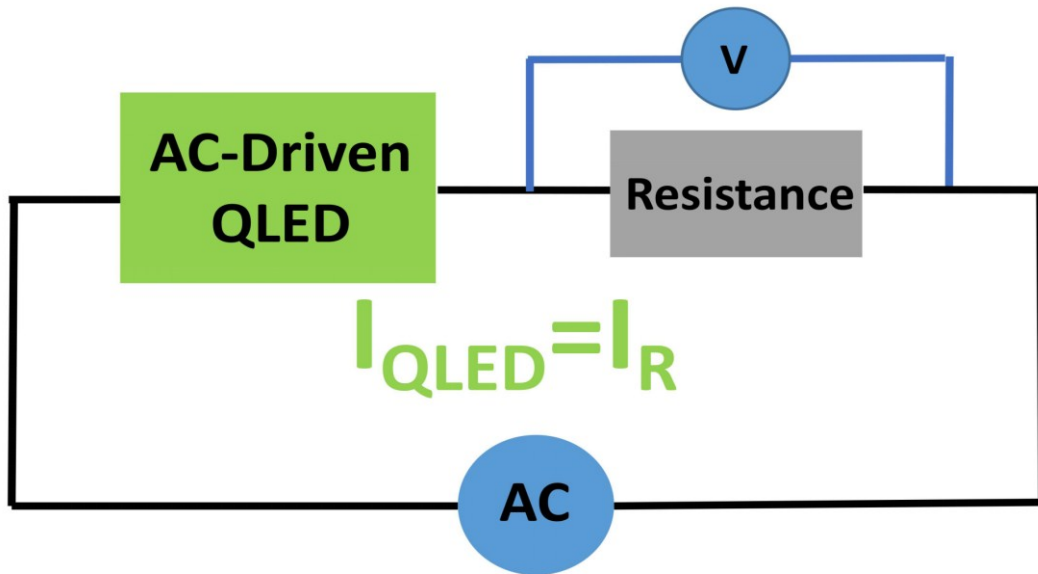

**Figure S2.** Method of measuring the current of AC-driven QLED.

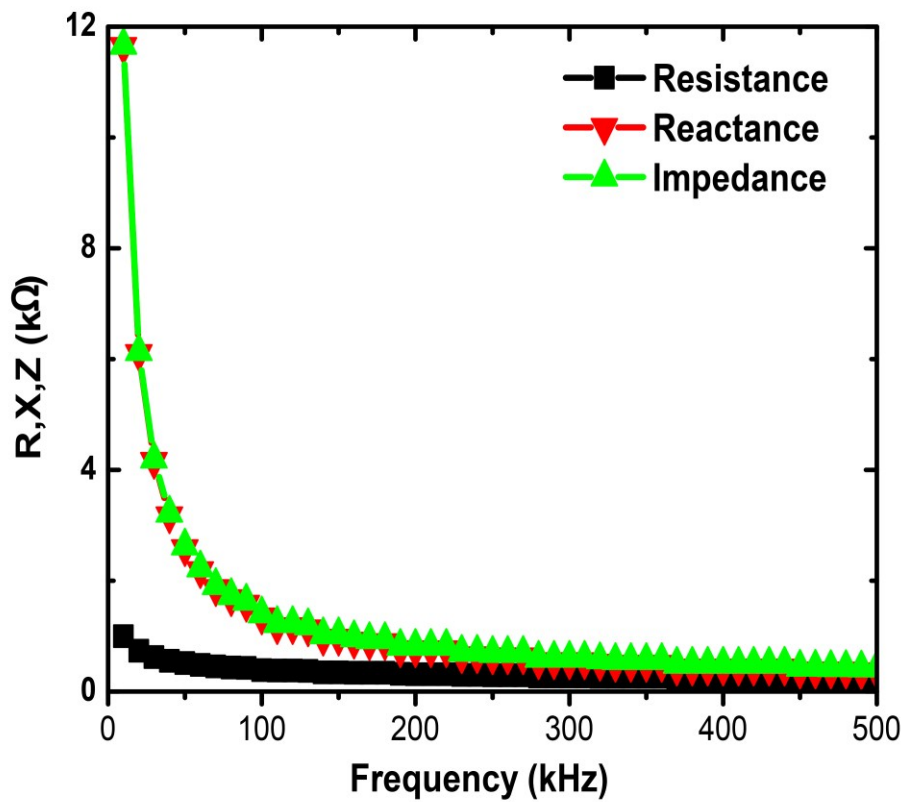

**Figure S3.** Resistance, reactance and impedance as functions of frequency.

**Table S1.** The key performances of the representative AC-driven devices in literature.

Device Structure	Device Type	Insulation Type	Color	Max L (cd m <sup>-2</sup> )	Max CE (cd A <sup>-1</sup> )	Ref.
ITO/SiO <sub>2</sub> /Alq <sub>3</sub> /SiO <sub>2</sub> /Al	AC-OLED	Double-insulation	Blue	-	-	1
ITO/PVP/PVK/BND/MEH-PPV/ITO/PVK/BND/MEH-PPV/PVP/Al	AC-OLED	Double-insulation	Orange-Red	261	-	2
ITO/SiO <sub>2</sub> /CNT:PS-b-PPP:F8BT/Au	AC-OLED	Single-insulation	Yellow	350	-	3
ITO/HfO <sub>2</sub> /MeO-TPD:F6TCNNQ/Spiro-TAD/TCTA:Ir(ppy) <sub>3</sub> /Bphen/Bphen:Cs/HfO <sub>2</sub> /Al	AC-OLED	Double-insulation	Green	500	-	4
ITO/P(VDF-TrFE)/PVK:Ir(ppy) <sub>3</sub> /Ca/Al	AC-OLED	Single-insulation	Green	550	-	5
ITO/SiO <sub>2</sub> /MeO-TPD:F4TCNQ/NPB/Ir(MDQ) <sub>2</sub> (acac)/BPhen/BPhen:Cs/SiO <sub>2</sub> /Al	AC-OLED	Double-insulation	Orange-Red	1000	-	6
ITO/HfO <sub>2</sub> /MeO-TPD:F4TCNQ/NPB/Ir(MDQ) <sub>2</sub> (acac)/BPhen/BPhen:Cs/HfO <sub>2</sub> /Al	AC-OLED	Double-insulation	Orange-Red	1500	-	7
ITO/SiO <sub>2</sub> /NWNTs:PS-b-P4VP/B-G-R Layer/Ag	AC-OLED	Single-insulation	Red	5000	-	8
			Green	6000		
			Blue	2300		
ITO/SWNTs:P(VDF-TrFE-CFE)/P3HT:F4TCNQ/PVK:OXD-7:Ir(ppy) <sub>3</sub> /TmPyPB:Li <sub>2</sub> CO <sub>3</sub> /LiF/Al	AC-OLED	Single-insulation	Green	7210	33.8	9
ITO/P(VDF-TrFE-CFE)/Poly-TPD:F4TCNQ/PVK:OXD-7:Ir(ppy) <sub>3</sub> /TmPyPB/LiF/Al	AC-OLED	Single-insulation	Green	13500	72.5	10
ITO/P(VDF-TrFE-CFE)/P3HT:F4TCNQ/PVK:OXD-7:Phosphors/TmPyPB/LiF/Al	AC-OLED	Single-insulation	Orange-Red	1600	8.8	11
			Green	13800	76.4	
			Blue	3000	15.8	
ITO/P(VDF-TrFE-CFE)/P3HT:F4TCNQ/PVK:OXD-7:Ir(ppy) <sub>3</sub> /TmPyPB/LiF/Al	AC-OLED	Single-insulation	Green	20500	110.7	12
ITO/Al <sub>2</sub> O <sub>3</sub> /ZnS/ZnSe/ZnS:Mn/ZnS/ Al <sub>2</sub> O <sub>3</sub> /ITO	AC-TFEL	Double-insulation	Orange	-	-	13
ITO/SiO <sub>2</sub> /F8BT:QDs/Au	AC-Q/OLED	Single-insulation	Green	650	-	14
ITO/SiO <sub>2</sub> /QDs:PIB/SiO <sub>2</sub> /Al	AC-QLED	Double-insulation	R/G/B	-	-	15
ITO/AL <sub>2</sub> O <sub>3</sub> /QDs:PIB/ZnO/ZnS:Cu/Conductive tape	AC-QLED	Single-insulation	R/G/B	-	-	16
Al/Si/Si QD/Si/SiO <sub>2</sub> /ITO	AC-QLED	Double-insulation	Near Infrared	-	-	17
ITO/QDs:MEH-PPV/Phosphor/Ag	AC-QLED	Double-insulation	Orange	18.6	-	18
			Green	82.3		
			Blue	49.2		
ITO/P(VDF-TrFE-CFE)/MoO <sub>3</sub> /TFB/QDs/ZnMgO/Al	AC-QLED	Single-insulation	Green	65760	4.4	ours

## References

- [1] X. L. Xu, X. H. Chen, Y. B. Hou, Z. Xu, X. H. Yang, S. G. Yin, Z. J. Wang, X. R. Xu, S. P. Lau, B. K. Tay, Blue electroluminescence from tris-(8-hydroxyquinoline)

- aluminum thin film, *Chem. Phys. Lett.*, 2000, **325**, 420-424.
- [2] S. B. Lee, K. Fujita, T. Tsutsui, Emission Mechanism of Double-Insulating Organic Electroluminescence Device Driven at AC Voltage, *Jpn. J. Appl. Phys.*, 2005, **44**, 6607-6611.
- [3] J. Sung, Y. S. Choi, S. J. Kang, S. H. Cho, T. Lee, C. Park, AC field-induced polymer electroluminescence with single wall carbon nanotubes, *Nano Lett.*, 2011, **11**, 966-972.
- [4] M. Fröbel, A. Perumal, T. Schwab, M. C. Gather, B. Lüssem, K. Leo, Enhancing the efficiency of alternating current driven organic light-emitting devices by optimizing the operation frequency, *Org. Electron*, 2013, **14**, 809-813.
- [5] Y. Xia, Y. Chen, G. M. Smith, Y. Li, W. X. Huang, D. L. Carroll, Carroll, D. L. Effects of electrode modification using calcium on the performance of alternating current field-induced polymer electroluminescent devices, *Appl. Phys. Lett.*, 2013, **102**, 253302.
- [6] A. Perumal, M. Fröbel, S. Gorantla, T. Gemming, B. Lüssem, J. Eckert, K. Leo, Novel Approach for Alternating Current (AC)-Driven Organic Light-Emitting Devices, *Adv. Funct. Mater.*, 2012, **22**, 210-217.
- [7] A. Perumal, B. Lüsse, K. Leo, High brightness alternating current electroluminescence with organic light emitting material, *Appl. Phys. Lett.*, 2012, **100**, 68.
- [8] S. H. Cho, S. S. Jo, I. Hwang, J. Sung, J. Seo, S. Jung, I. Bae, J. R. Choi, H. Cho, T. Lee, J. K. Lee, T. Lee, C. Park, Extremely Bright Full Color Alternating Current Electroluminescence of Solution-Blended Fluorescent Polymers with Self-Assembled Block Copolymer Micelles, *ACS Nano*, 2013, **7**, 10809-10817.
- [9] Y. Chen, Y. Xia, G. M. Smith, C. A. Hewitt, Q. Fu, Y. Liu, H. Sun, D. Ma, Y. Gu, C. Yang, Y. Mei, D. L. Carroll, High-color-quality white emission in AC-driven field-induced polymer electroluminescent devices, *Org. Electron*, 2014, **15**, 182-188.
- [10] Y. Chen, Y. Xia, G. M. Smith, D. L. Carroll, Electroluminescent devices: frequency-dependent, alternating current-driven, field-induced polymer electroluminescent devices with high power efficiency, *Adv. Mater.*, 2014, **26**, 8133-

8140.

[11] Y. Chen, Y. Xia, H. Sun, G. M. Smith, D. Yang, D. Ma, D. L. Carroll, Thin Films: Solution-Processed Highly Efficient Alternating Current-Driven Field-Induced Polymer Electroluminescent Devices Employing High-k Relaxor Ferroelectric Polymer Dielectric, *Adv. Funct. Mater.*, 2014, **24**, 1501-1508.

[12] Y. Chen, Y. Xia, G. M. Smith, H. Sun, D. Yang, D. Ma, Y. Li, W. Huang, D. L. Carroll, *Adv. Funct. Mater.* 2014, **24**, 2677.

[13] V. Wood, J. Halpert, M. J. Panzer, M. Bawendi, Alternating Current Driven Electroluminescence from ZnSe/ZnS:Mn/ZnS Nanocrystals, *Nano Lett.*, 2009, **9**, 2367-2371.

[14] S. H. Cho, J. Sung, I. Hwang, R. H. Kim, Y. S. Choi, S. S. Jo, T. W. Lee, C. Park, High Performance AC Electroluminescence from Colloidal Quantum Dot Hybrids, *Adv. Mater.*, 2012, **24**, 4540-4546.

[15] V. Wood, M. J. Panzer, D. Bozyigit, Y. Shirasaki, I. Rousseau, S. Geyer, M. Bawendi, V. Bulovic, Electroluminescence from Nanoscale Materials via Field-Driven Ionization, *Nano Lett.*, 2011, **11**, 2927-2932.

[16] V. Wood, M. J. Panzer, J. Chen, M. S. Bradley, J. Halpert, M. Bawendi, V. Bulovic, Inkjet-printed Quantum Dot-Polymer Composites for Full-color AC-driven Displays, *Adv. Mater.*, 2010, **21**, 2151-2155.

[17] W. W. Mu, P. Zhang, J. Xu, S. H. Sun, J. Xu, W. Li, K. J. Chen, Direct-Current and Alternating-Current Driving Si Quantum Dots-Based Light Emitting Device, *IEEE J. Quantum Elect.*, 2014, **20**, 206-211.

[18] R. M. Taylor, K. H. Church, M. I. Sluch, Red light emission from hybrid organic/inorganic quantum dot AC light emitting displays, *Displays*, 2007, **28**, 92-96.