

# **Adhesive Bacterial Amyloid Nanofibers-Mediated Growth of Metal-Organic Frameworks on Diverse Polymeric Substrates**

Cuizheng Zhang,<sup>a, †</sup> Yingfeng Li,<sup>a, b, c, †</sup> Hongliang Wang,<sup>a</sup> Sanfeng He,<sup>a</sup> Yiyi Xu,<sup>a</sup> Chao Zhong<sup>\*a</sup>  
and Tao Li<sup>\*a</sup>

## **Affiliations:**

<sup>a</sup>School of Physical Science and Technology, ShanghaiTech University, Shanghai  
201210, China.

<sup>b</sup>Shanghai Institute of Ceramics, Chinese Academy of Sciences, Shanghai 200050,  
China.

<sup>c</sup>University of Chinese Academy of Sciences, Beijing100049, China.

<sup>†</sup>These authors contributed equally to this work.

## **Corresponding authors:**

E-mail: litao1@shanghaitech.edu.cn

zhongchao@shanghaitech.edu.cn

## **Table of Contents:**

Materials and Methods

Figures S1 to S21

References

## **Materials and Methods:**

1 Materials

2 Characterization

3 CsgA sequence

4 6FDA-DAM membrane fabrication

5 CsgA proteins expression and purification

6 General protocol to prepare curli nanofiber coatings on different substrates

7 Sub-100 nm ZIF-8 growth

8 Tape peel test

9 Micron-sized ZIF-8 growth<sup>1</sup>

10 UiO-66 growth

11 Pre-treatment of Sylgard 184

12 Fabrication of TFC membranes

## **Materials**

All reagents were obtained through commercial sources without further purification unless specified.

Methyl-2-pyrrolidinone (NMP) and chloroform were heated under reflux for 4 hours over  $\text{CaH}_2$  before distillation.

4,4'-(Hexafluoroisopropylidene) diphthalic anhydride (6FDA) was purified by vacuum sublimation at 215 °C. 2,4,6-trimethyl-1,3-phenylenediamine (DAM) was purified by recrystallization in ethanol.

6FDA-DAM polyimide was synthesized according the reported method.<sup>2</sup> Specifically, 2.152 g (14.33 mmol) DAM was completely dissolved in 15 mL dry NMP in a round button flask. The flask was then immersed in an ice-bath. 6.364 g (14.33 mmol) 6FDA and additional 15 mL NMP were added. Then the mixture was stirred for 24 hours to form a viscous poly(amic acid) solution. For the imidization, a mixture of 2 mL triethylamine, 5.4 mL of acetic anhydride and 6 mL NMP was added. The mixture was stirred at room temperature for another 24 hours. And then slowly ejected into methanol through a syringe, yielding white polyimide fibers. The obtained polyimide was thoroughly washed and exchanged with methanol for several days before drying in a vacuum oven at 200 °C for 24 hours.

## **Characterization**

### **Scanning electron microscope (SEM)**

SEM images were obtained using a Phenom Pro-Scanning electron microscopy (15 kV). Samples were coated with Au for 30 seconds using a SBC-12 sputter coater. High-resolution SEM images were obtained using a JSM-7800F Prime Scanning Electron Microscopy. Samples were coated with Au for 10 seconds using a SBC-12 sputter coater.

### **Transmission electron microscope (TEM)**

TEM images were taken on JEM 2100 plus (200 kV). Briefly, 20  $\mu\text{L}$  CsgA nanofiber solution was directly deposited on TEM grids for 30 seconds. Then, excessive solution was wicked away with pieces of filter paper. Samples were negatively stained with 5  $\mu\text{L}$  2 wt% uranyl acetate for 1 min. After wicking off, the grid was dried for 15 minutes under an infrared lamp.

### **Powder X-ray diffraction (PXRD)**

PXRD patterns were collected in the  $2\theta$  range of  $5 - 30^\circ$  at room temperature on a Bruker D2 X-ray diffractometer with Cu  $K\alpha$  radiation ( $\lambda = 1.54184 \text{ \AA}$ ) at a scan rate of  $2^\circ/\text{min}$  and a step size of  $0.02^\circ$ .

### **Gas chromatography (GC)**

GC curves were got from Techcomp GC D7900P equipped with a GDX-502 packed column. Briefly, an equimolar binary gas mixture of  $\text{C}_3\text{H}_6$  and  $\text{C}_3\text{H}_8$  was used as feed gas. The total up-stream volumetric flow rate was set to 8 scc/min. A helium

(99.999%) cylinder which used as downstream sweep gas was attached to the membrane cell controlled via a mass flow controller and the volumetric flow rate was set to 10 sccm. The transmembrane pressure (TMP) was controlled through a back pressure valve. The membrane cell, column oven and thermal conductivity detector (TCD) temperature were maintained at 35, 100 and 150 °C. At each pressure point, the system was stabilized for 30 minutes and the measurement was repeated for at least 3 times.

### **Water contact angle measurements**

Contact angle data were collected on a USA KINO Industry Optical Contact Angle SL200KS and the drop shape was fitted using circle model.

### **Atomic force microscope (AFM)**

AFM images were obtained by an Asylum MFP-3D-Bio AFM on AC air tapping mode using AC160TS-R3 cantilevers (Olympus,  $k \approx 26$  N/m,  $\nu \approx 300$  kHz).

### **X-ray photoelectron spectroscopy (XPS)**

XPS spectrum was performed on a Thermo Fisher ESCALAB 250 Xi.

### **CsgA sequence**

MGVVPQYGGGGNHGGGGNNSGPNSELNIYQYGGGNSALALQTDARNSDLTI

TQHGGGNGADVGGQGSDDSSIDLTQRGFGNSATLDQWNGKNSEMTVKQFGG  
GNGAAVDQTASNSSVNVTQVGFGNNATAHQYHHHHHH

### **6FDA-DAM membrane fabrication**

To prepare dense 6FDA-DAM membranes, 8 wt% 6FDA-DAM in dry chloroform solution was filtered through a 0.45 mm PTFE syringe filter directly onto a casting tray. The tray is composed of a glass ring attached to a leveled glass plate by epoxy sealant. After slow evaporation of the solvent, the membrane was lifted off from the glass plate with the aid of a drop of water.

### **CsgA proteins expression and purification**

20 mL LB broth containing CsgA plate was cultured overnight. An additional 1 liter of room-temperature LB was added to the culture which was then grown to OD<sub>600</sub> 1.0. Isopropyl-β-D-thiogalactopyranoside (IPTG) was then added to a final concentration of 1 mM and was incubated for 60 min at 37 °C. The culture was centrifuged for 10 min at 4000 g at 4 °C. Every 5 g pellets were lysed by 50 mL Guanidine hydrochloride (GdnHCl 8 M, 300 mM NaCl, 50mM K<sub>2</sub>HPO<sub>4</sub>/KH<sub>2</sub>PO<sub>4</sub>, pH = 8) for 12 hours at room temperature. Supernatants of the lysates were collected at 12,000 × g for 30 minutes before loading onto a His-Select Ni-NTA column. The column was washed with KPI (300 mM NaCl, 50 mM K<sub>2</sub>HPO<sub>4</sub>/KH<sub>2</sub>PO<sub>4</sub>, pH = 8)

buffer and 20 mM imidazole KPI buffer, then eluted with 300 mM imidazole KPI buffer.

### **General protocol to prepare curli nanofiber coatings on different substrates**

Various substrates (flat or 3D) were immersed in fresh made CsgA monomer (~ 1 mg/mL) solution overnight. After CsgA forming curli nanofibers (CNFs), substrates were washed by deionized H<sub>2</sub>O and dried under a stream of nitrogen.

### **Sub-100 nm ZIF-8 growth**

For the growth of ZIF-8, separate stock solutions of Zn(NO<sub>3</sub>)<sub>2</sub>·6H<sub>2</sub>O (14.7 mg, 0.0494 mmol) in 1 mL MeOH and 2- methylimidazole (HMIM) (32.4 mg, 0.3952 mmol) in 1 mL MeOH were prepared. TEM grids, silicon substrate with and without curli nanofiber coatings and PS substrate with and without curli nanofiber coatings were first mixed with Zn(NO<sub>3</sub>)<sub>2</sub>·6H<sub>2</sub>O stock solution and then the latter solution was added. After 24 hours, substrates were washed three times in methanol and dried under a stream of nitrogen. TEM grids and silicon substrate with and without curli nanofiber coatings were used to confirm the nucleation roles of curli nanofibers on MOF growth. PS substrate with and without curli nanofiber coatings were used to the tape peel tests.

### **Tape peel test**

A high-tack tape (VHB, 3M, with an adhesion to steel value of  $2,600 \text{ N m}^{-1}$ ) was gently pressed onto each substrate with a thumb before peeling off. The substrates were then subjected to SEM and optical microscope characterization.

### **Micron-sized ZIF-8 growth**

For the growth of ZIF-8, separate stock solutions of  $\text{Zn}(\text{NO}_3)_2 \cdot 6\text{H}_2\text{O}$  (14.7 mg, 0.0494 mmol) in 1 mL MeOH and 2- methylimidazole (HMIM) (16.2 mg, 0.197 mmol) and 1- methylimidazole (15.7  $\mu\text{L}$ , 0.197 mmol) in 1 mL MeOH were prepared. Various substrates (flat or 3D) were first mixed with  $\text{Zn}(\text{NO}_3)_2 \cdot 6\text{H}_2\text{O}$  stock solution and then the latter solution was added. After 24 hours, substrates were washed three times in methanol and dried under a stream of nitrogen.

### **UiO-66 growth**

29.1 mg (0.125 mmol)  $\text{ZrCl}_4$  and 20.8 mg (0.125 mmol) terephthalic acid were dissolved in 5 ml N, N-Dimethylformamide (DMF) and then 686  $\mu\text{L}$  acetic acid was added. After submerging a piece of PTFE in the solution, the reaction mixture was heated in a  $120 \text{ }^\circ\text{C}$  oven for 24 hours. Then, the PTFE plate was washed three times in DMF and dried under a stream of nitrogen.

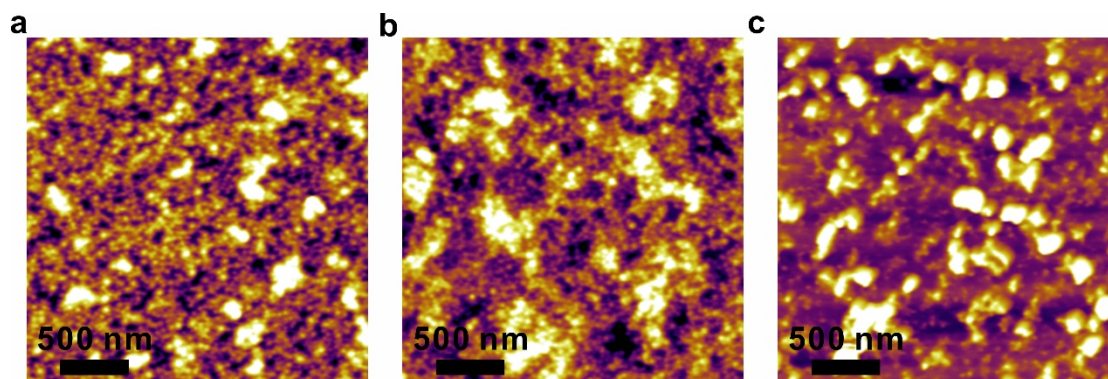


### **Pre-treatment of Sylgard 184**

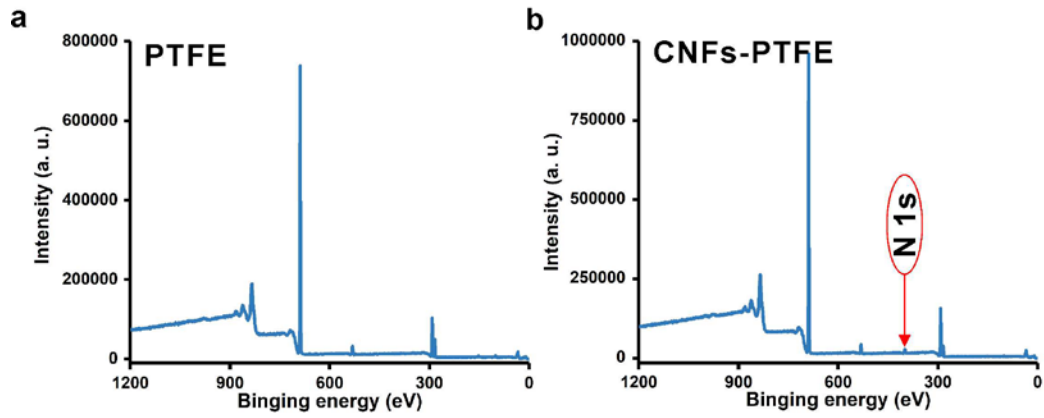
1.39 mL Sylgard 184 A and 136  $\mu$ L sylgard 184 B were mixed and dissolved in 12.9 mL hexane and sonicated for 1 min. Then the solution was pre-crosslinked under a UV lamp at 60 °C for 18 hours.

### **Fabrication of TFC membrane**

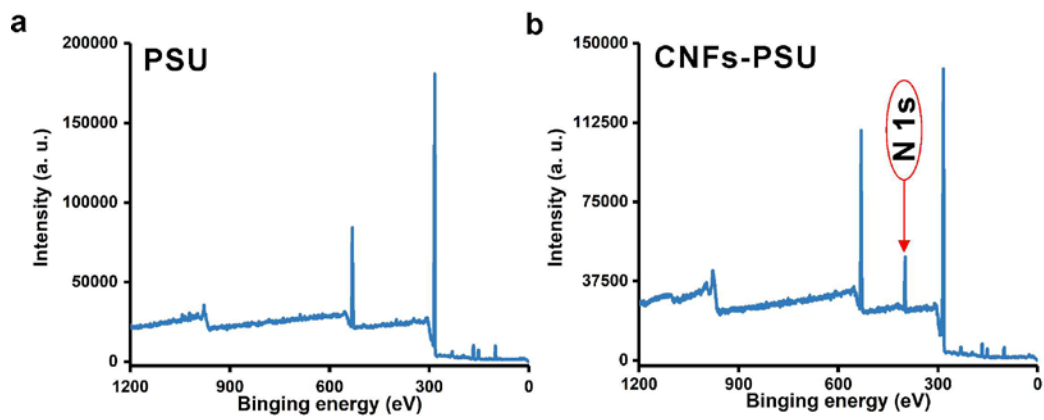
The ZIF-8 was first grown on a microporous PVDF support with a surface coverage of  $93 \pm 1$  % (denoted as ZIF-8@CNFs-PVDF). And then stock solutions of HMIM (20.5 g, 0.250 mol in 90 mL water) and  $\text{Zn}(\text{OAc})_2 \cdot 2\text{H}_2\text{O}$  (0.549 g, 2.5 mmol in 10 mL water) were prepared separately. Next ZIF-8@CNFs-PVDF was submerged in 2 mL HMIM stock solution first and then 146  $\mu$ L of  $\text{Zn}(\text{OAc})_2 \cdot 2\text{H}_2\text{O}$  stock solution was added. After 30 minutes, the membrane was washed by methanol three times and dried under a stream of nitrogen. This growth cycle was repeated five times. Finally, the membrane was installed on a brass mask with a 6 mm opening. Then 10  $\mu$ L of pre-treated of Sylgard 184 solution was drop casted on to the membrane. The TFC membrane was heated in an 80 °C oven for 30 minutes before use.



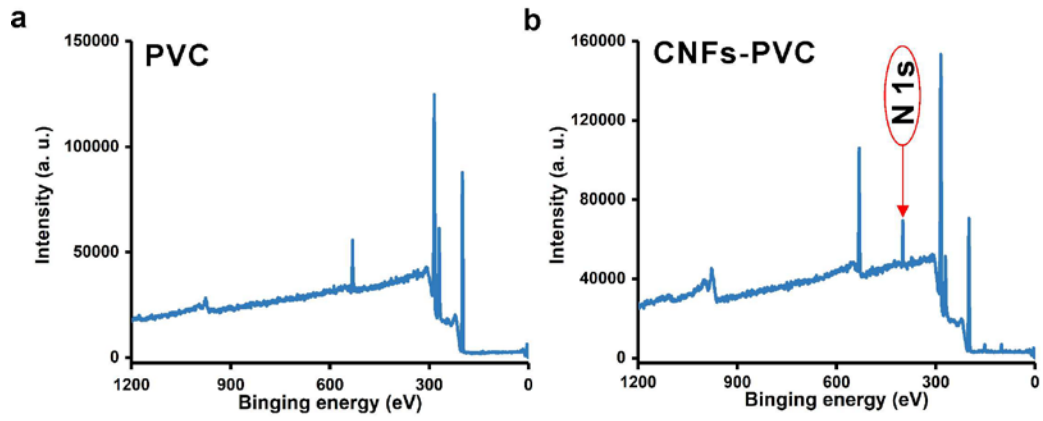
**Figure S1.** AFM images of sub-100 nm ZIF-8 particles grown on CNFs-coated silicon substrates for a) 10 mins, b) 30 mins and c) 60 mins.



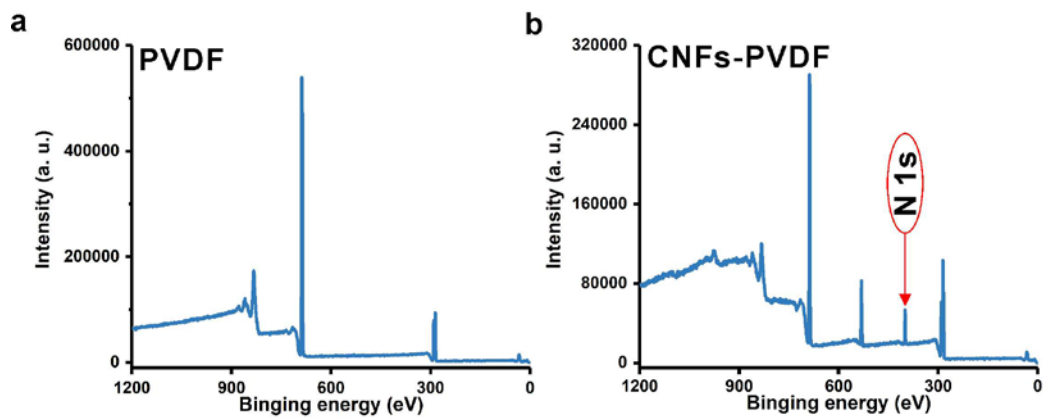
**Figure S2.** XPS spectrum of PTFE templates a) without and b) with curli nanofiber coatings.



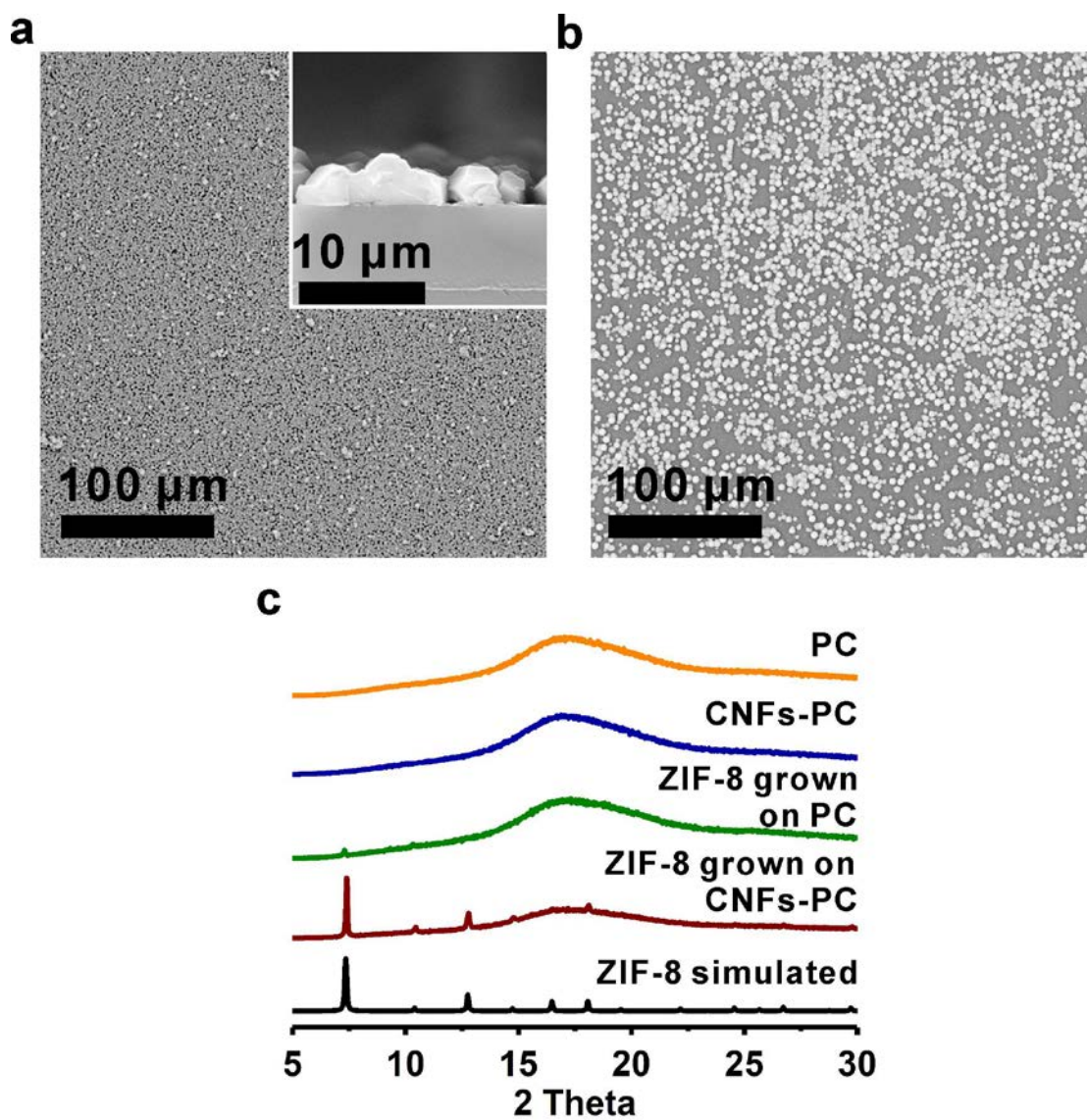
**Figure S3.** XPS spectrum of PSU templates a) without and b) with curli nanofiber coatings.



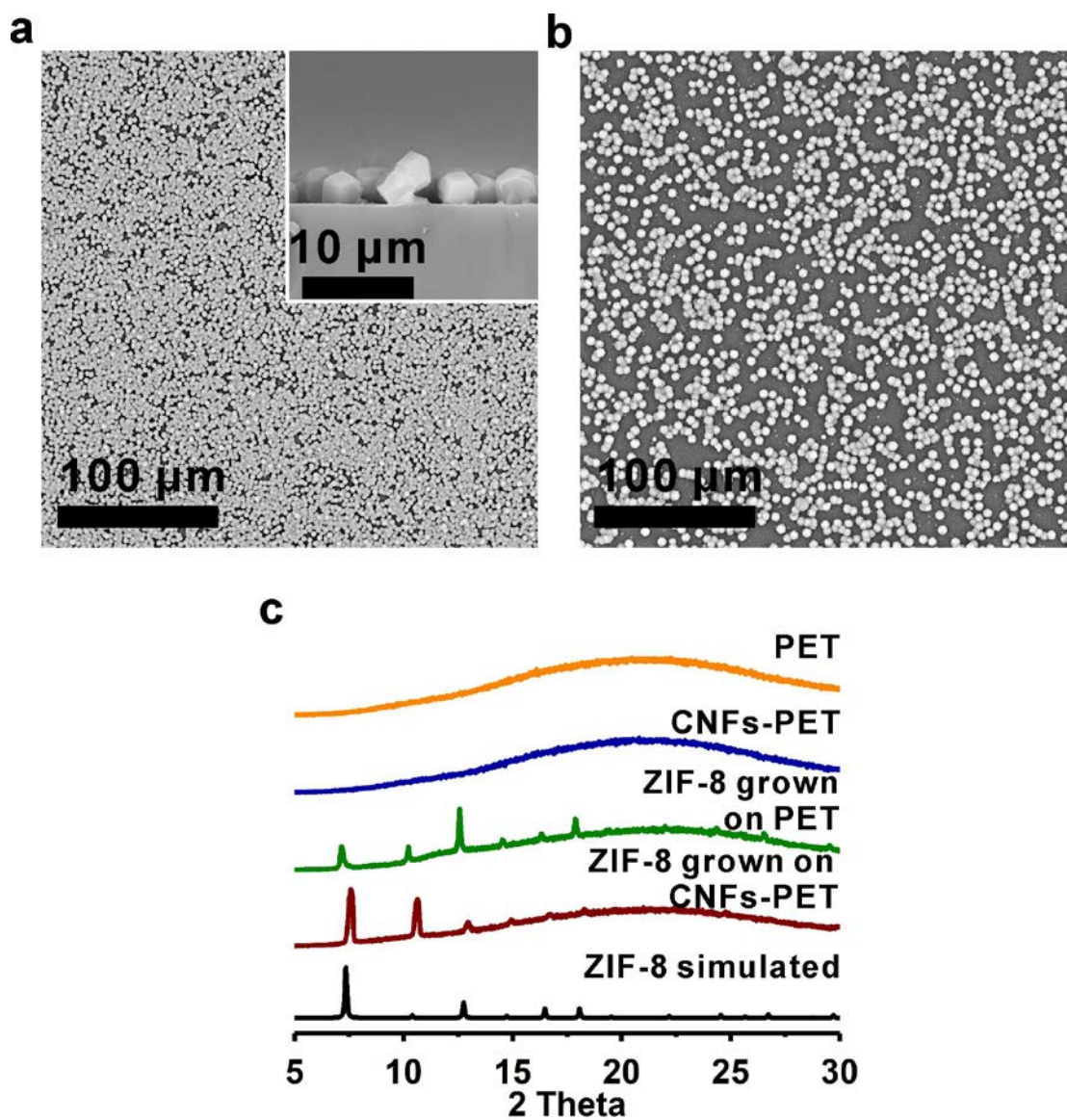
**Figure S4.** XPS spectrum of PVC templates a) without and b) with curli nanofiber coatings.



**Figure S5.** XPS spectrum of PVDF templates a) without and b) with curli nanofiber coatings.

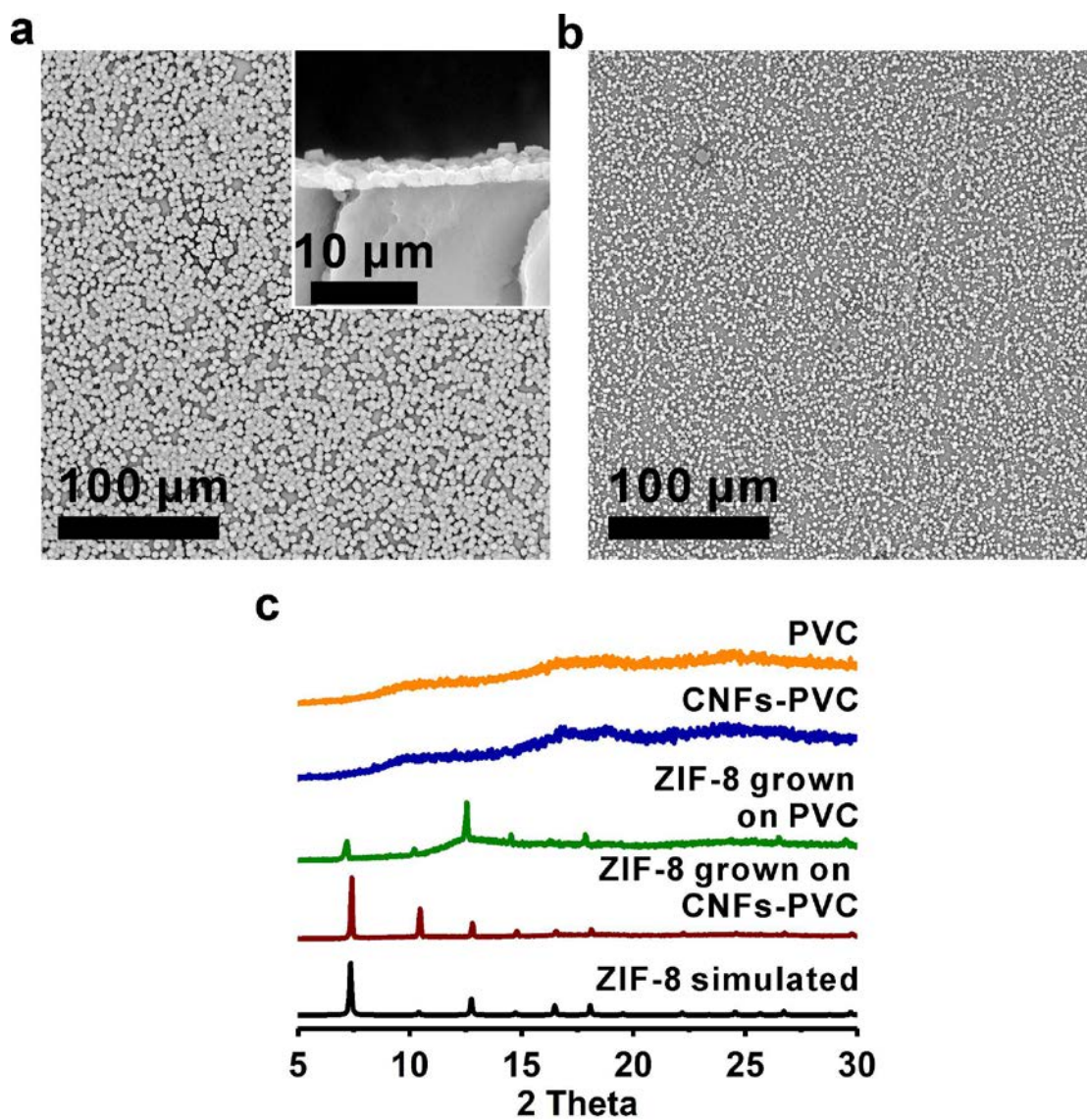


**Figure S6.** SEM images of micron-sized ZIF-8 particles grown on a) CNFs-coated PC and b) non-coated PC. The inset in a) is the cross-section SEM image of the corresponding sample. c) PXRD curves of different PC samples before and after ZIF-8 growth.

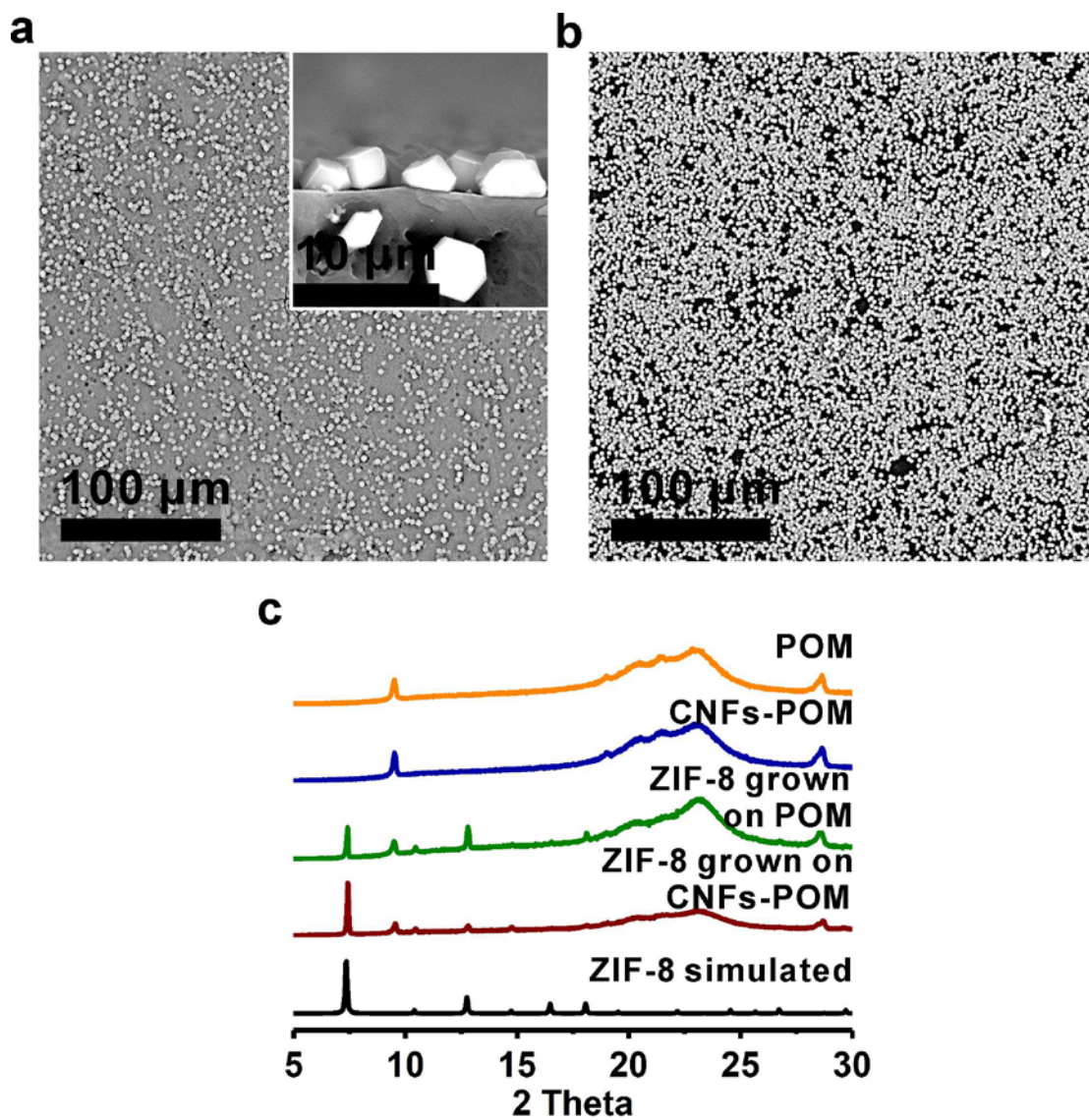


**Figure S7.** SEM images of micron-sized ZIF-8 particles grown on a) CNFs-coated PET and b) non-coated PET. The inset in a) is the cross-section SEM image of the corresponding sample. c) PXRD curves of different PET samples before and after ZIF-8 growth.



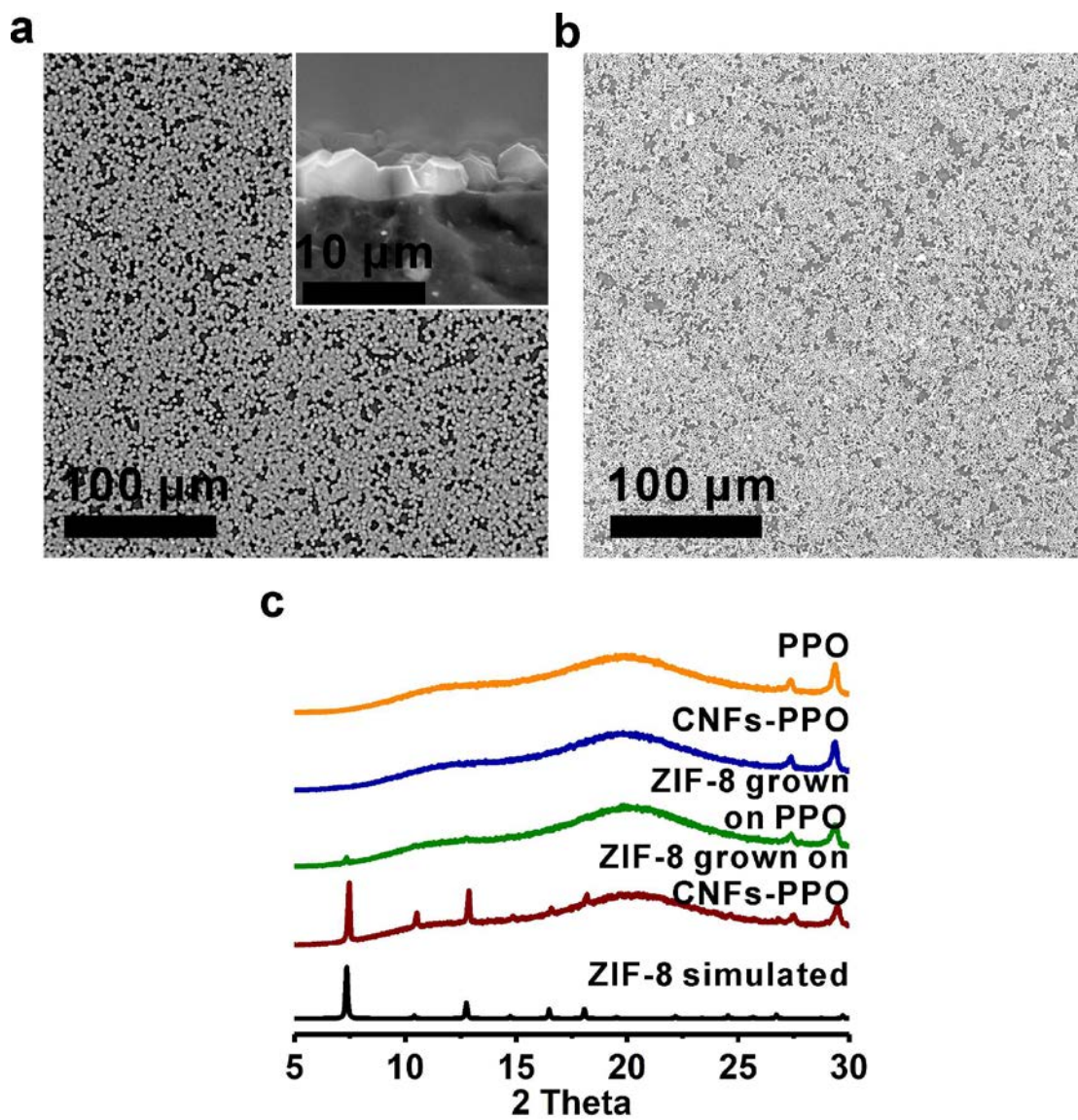


**Figure S8.** SEM images of micron-sized ZIF-8 particles grown on a) CNFs-coated PVC and b) non-coated PVC. The inset in a) is the cross-section SEM image of the corresponding sample. c) PXRD curves of different PVC samples before and after ZIF-8 growth.

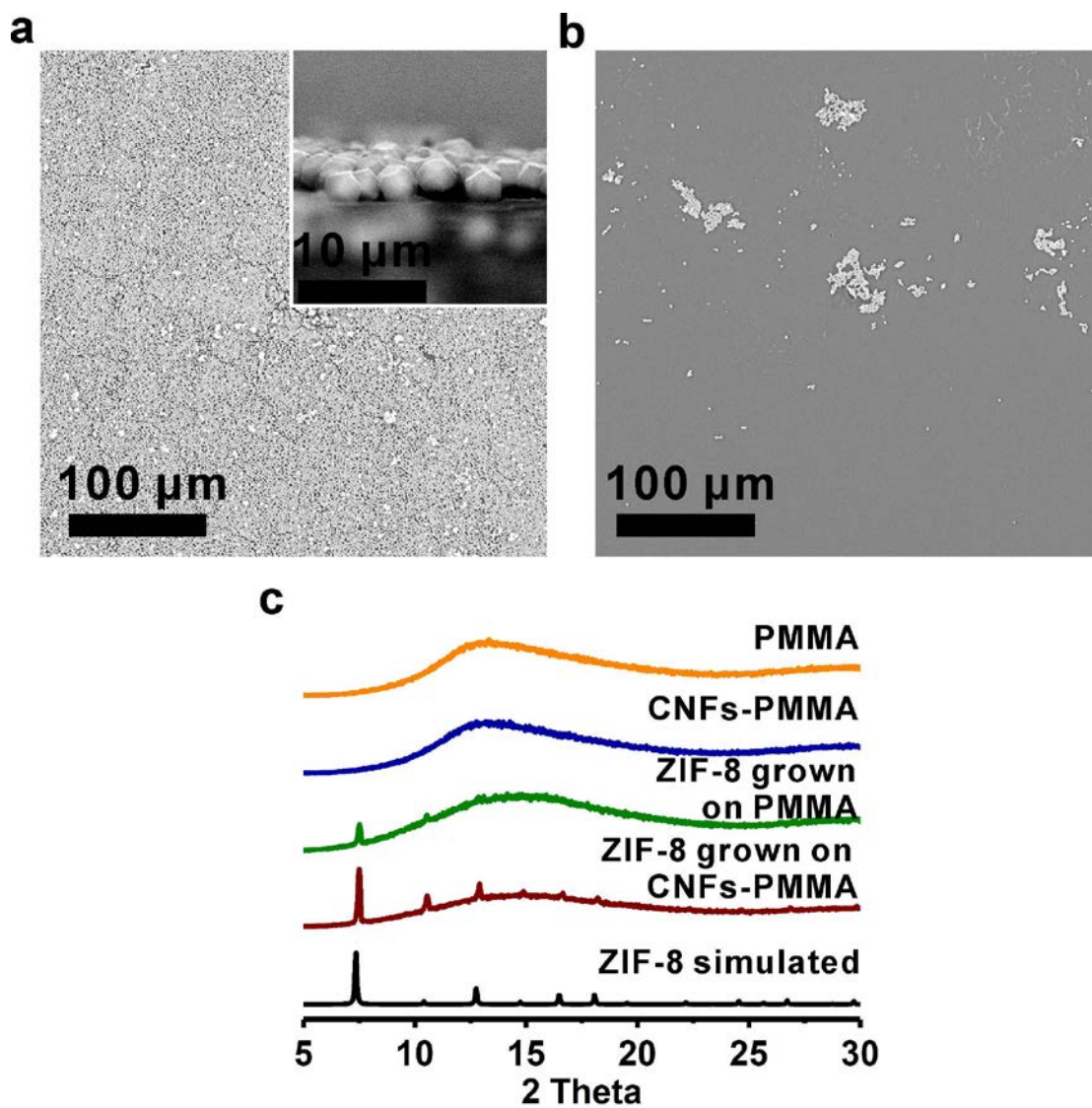


**Figure S9.** SEM images of micron-sized ZIF-8 particles grown on a) CNFs-coated POM and b) non-coated POM. The inset in a) is the cross-section SEM image of the corresponding sample. c) PXRD curves of different POM samples before and after ZIF-8 growth.

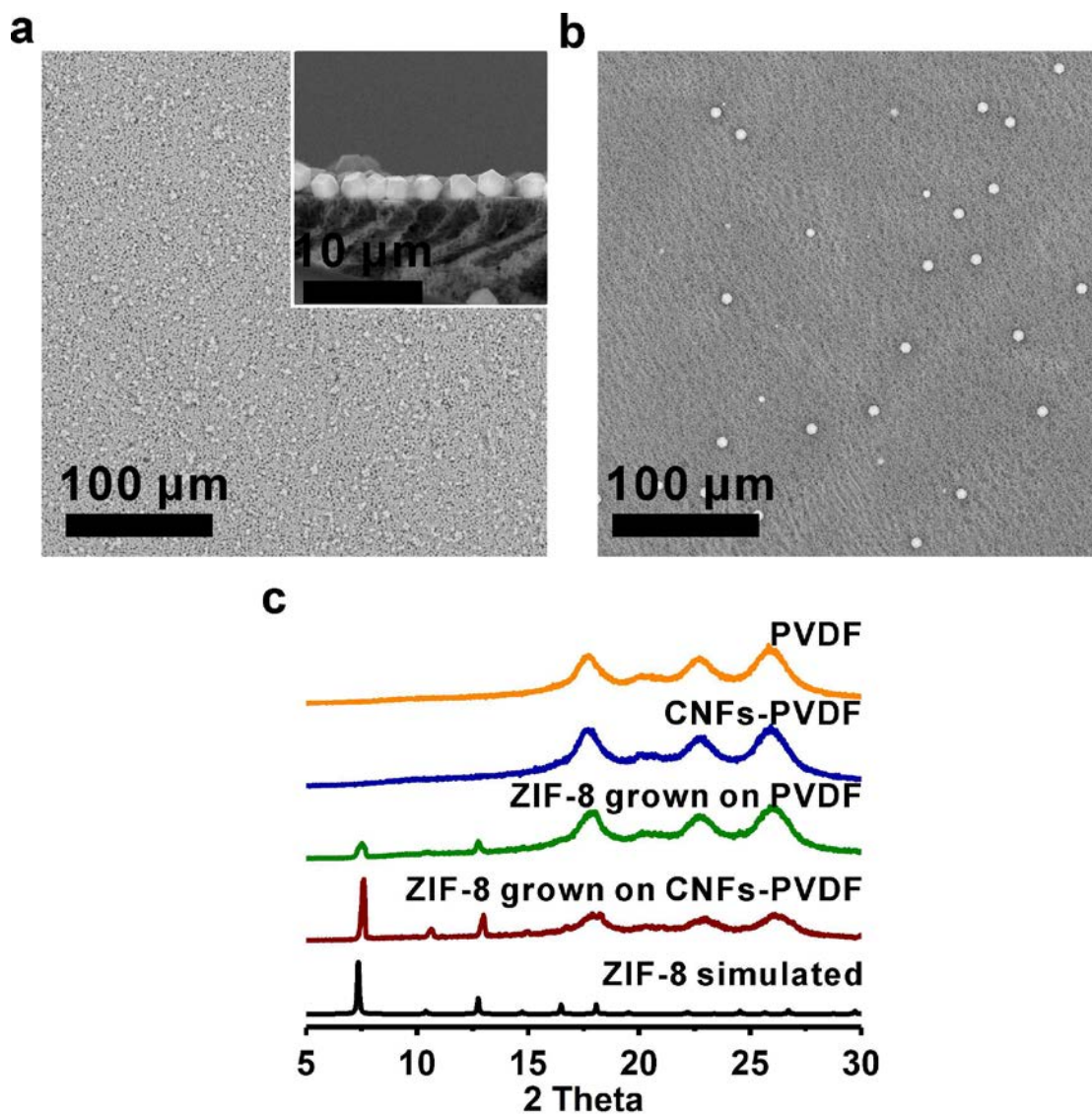




**Figure S10.** SEM images of micron-sized ZIF-8 particles grown on a) CNFs-coated PPO and b) non-coated PPO. The inset in a) is the cross-section SEM image of the corresponding sample. c) PXRD curves of different PPO samples before and after ZIF-8 growth.

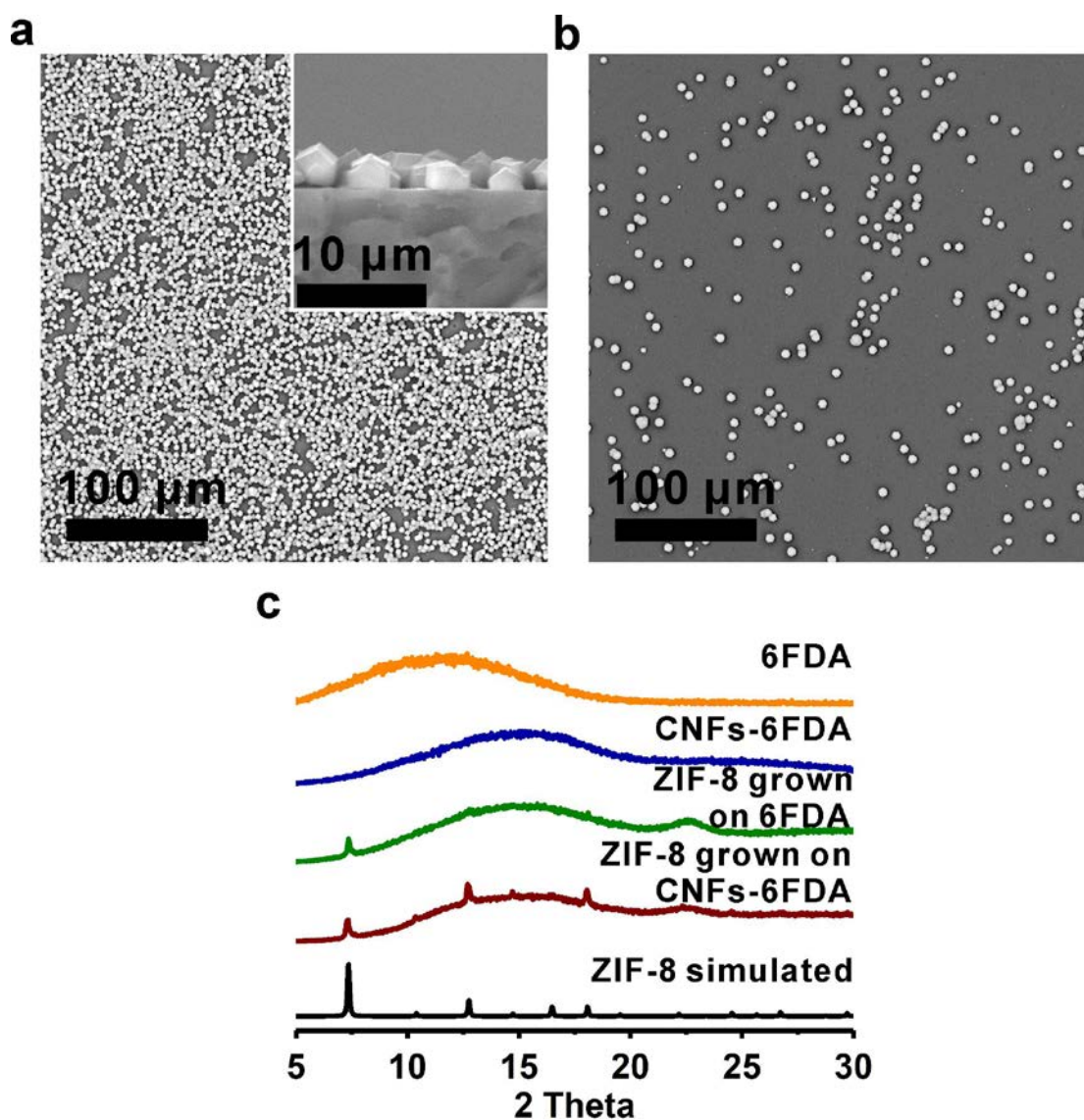


**Figure S11.** SEM images of micron-sized ZIF-8 particles grown on a) CNFs-coated PMMA and b) non-coated PMMA. The inset in a) is the cross-section SEM image of the corresponding sample. c) PXRD curves of different PMMA samples before and after ZIF-8 growth.

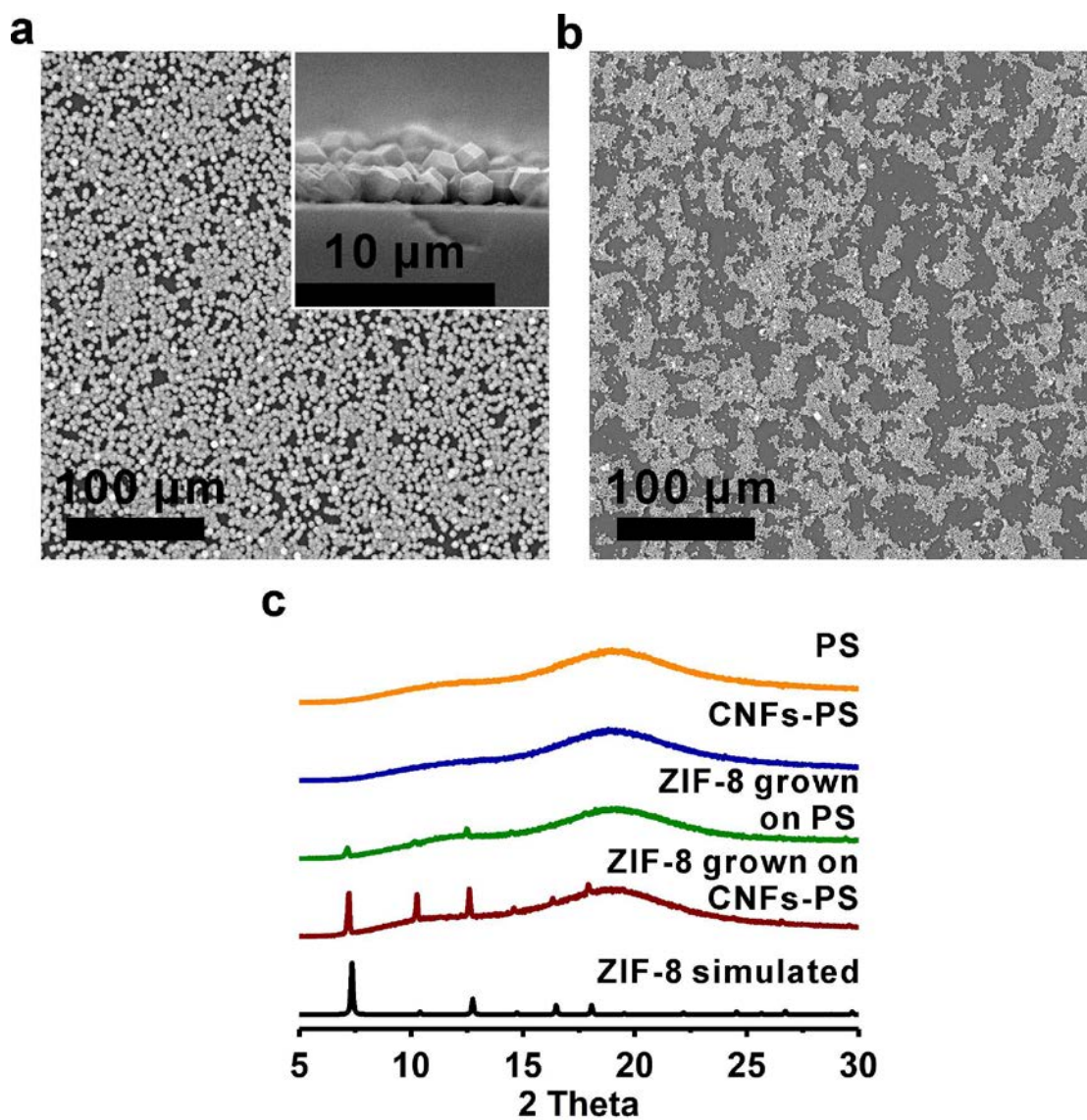


**Figure S12.** SEM images of micron-sized ZIF-8 particles grown on a) CNFs-coated PVDF and b) non-coated PVDF. The inset in a) is the cross-section SEM image of the corresponding sample. c) PXRD curves of different PVDF samples before and after ZIF-8 growth.

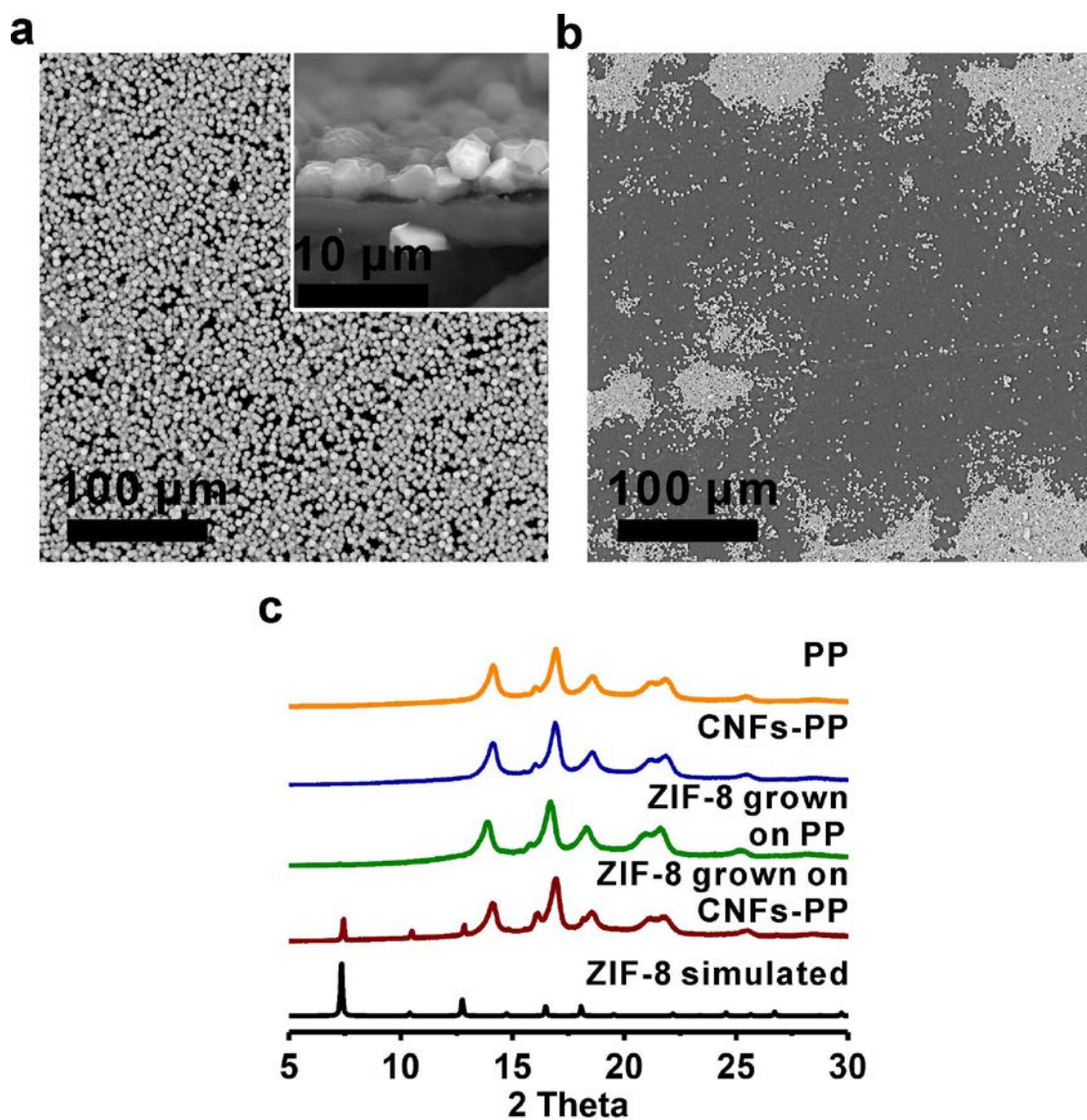




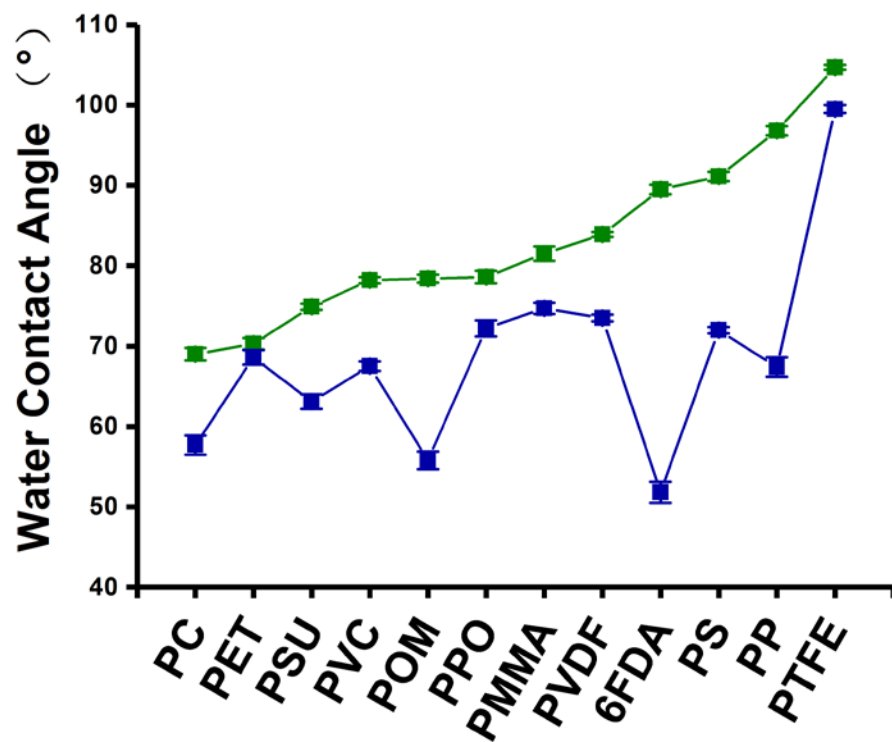
**Figure S13.** SEM images of micron-sized ZIF-8 particles grown on a) CNFs-coated 6FDA and b) non-coated 6FDA. The inset in a) is the cross-section SEM image of the corresponding sample. c) PXRD curves of different 6FDA samples before and after ZIF-8 growth.



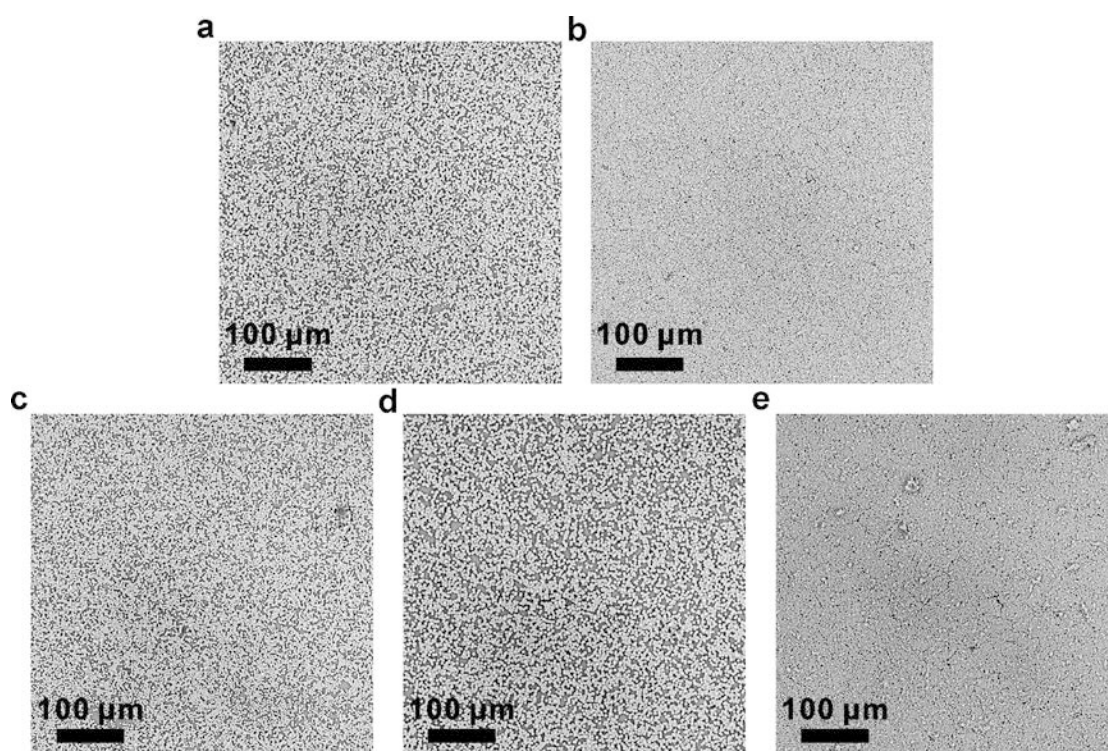
**Figure S14.** SEM images of micron-sized ZIF-8 particles grown on a) CNFs-coated PS and b) non-coated PS. The inset in a) is the cross-section SEM image of the corresponding sample. c) PXRD curves of different PS samples before and after ZIF-8 growth.



**Figure S15.** SEM images of micron-sized ZIF-8 particles grown on a) CNFs-coated PP and b) non-coated PP. The inset in a) is the cross-section SEM image of the corresponding sample. c) PXRD curves of different PP samples before and after ZIF-8 growth.

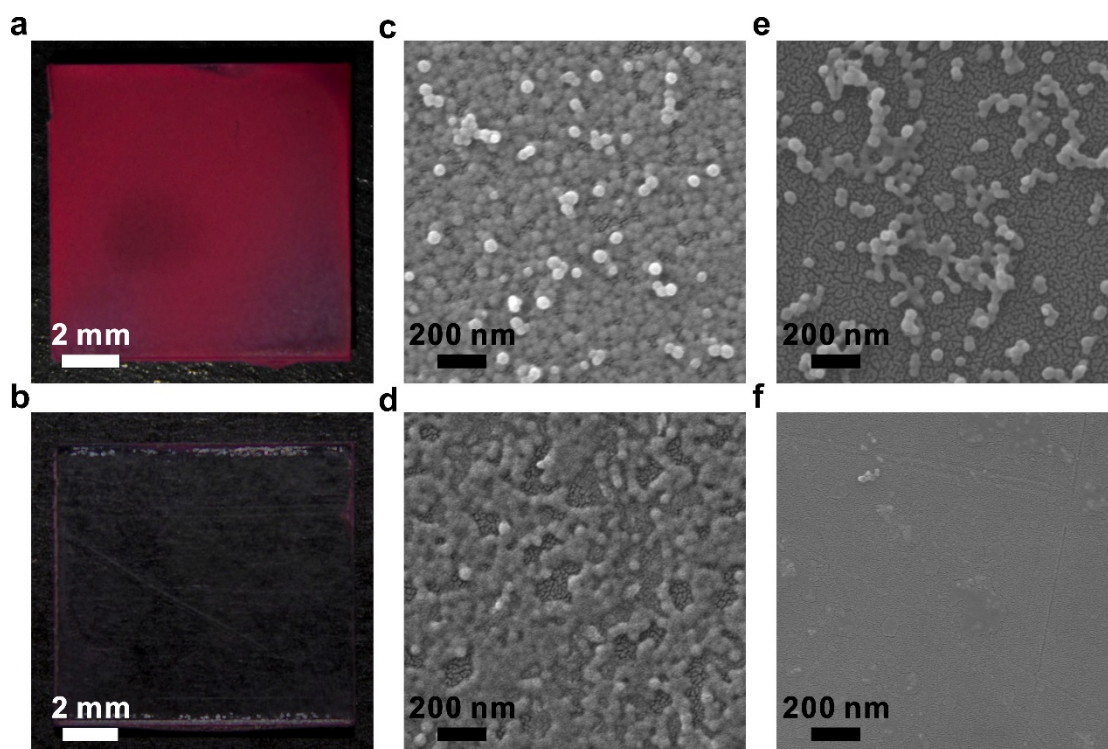


**Figure S16.** Water contact angle values of bare substrates (green) and CNFs-substrates (blue).

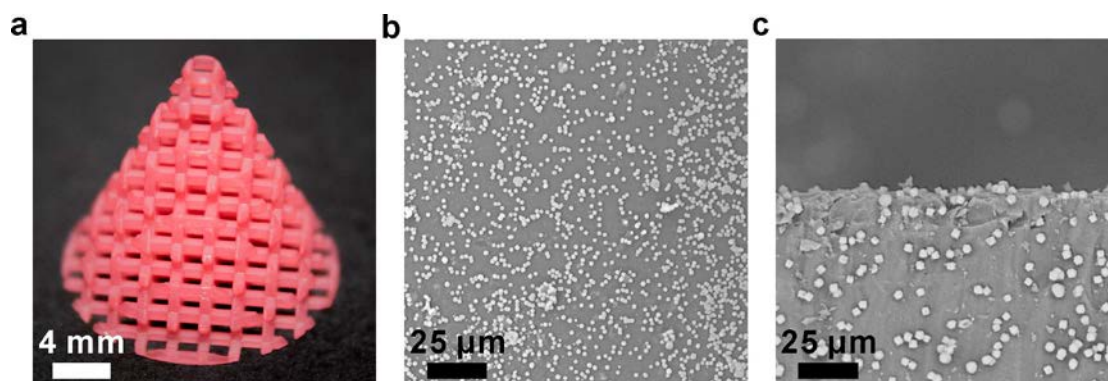


**Figure S17.** SEM images of micron-sized ZIF-8 crystals grown on CNFs-PTFE plates pre-treated by a) HCl pH=2, b) NaOH pH=12, c) DCM, d) DMF, and e) DMSO for 48 h.

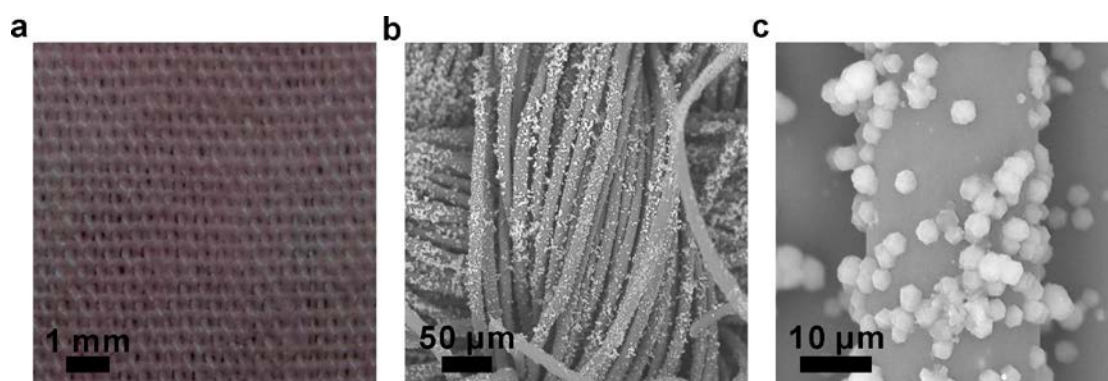




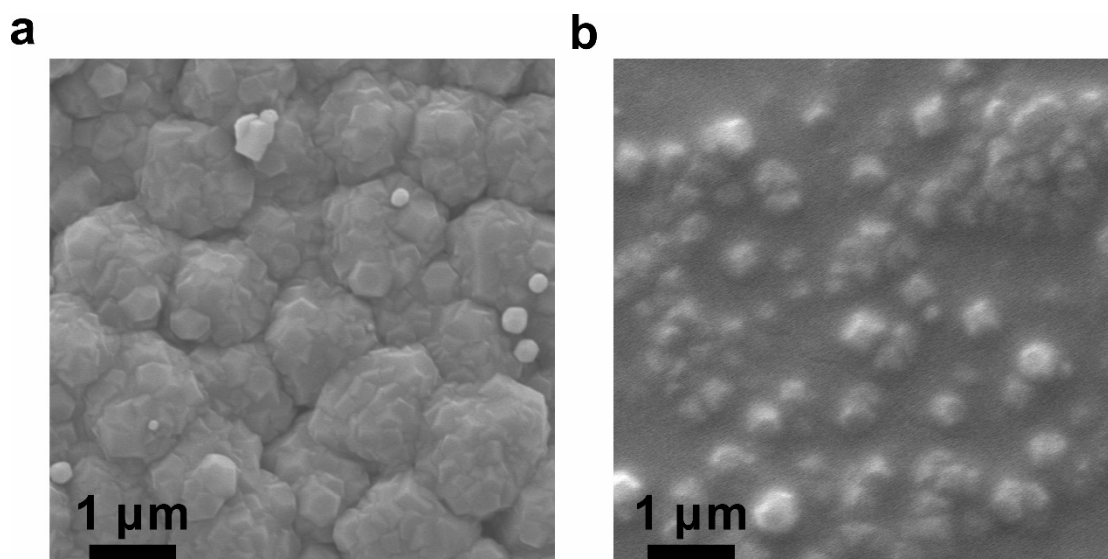
**Figure S18.** Photographs of micron-sized ZIF-8 (stained with congo red dye) grown on CNFs-coated PS a) before and b) after tape peel test. SEM images of sub-100 nm ZIF-8 grown on CNFs-coated PS c) before and d) after tape peel test. SEM images of sub-100 nm ZIF-8 grown on non-coated PS e) before and f) after tape peel test.



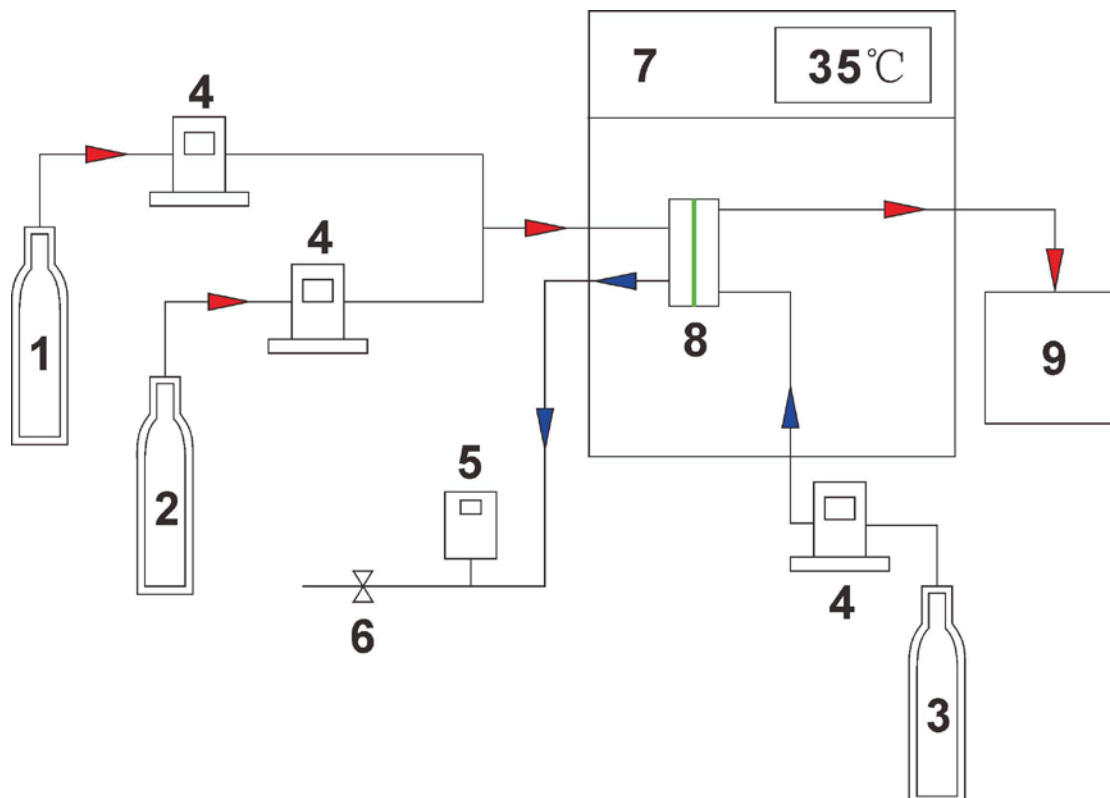
**Figure S19.** a) Photograph of micron-sized ZIF-8 grown on a 3D printed PR pyramid scaffold without curli nanofiber coatings. The SEM images of b) top view and c) one of the edge areas on the pyramid.



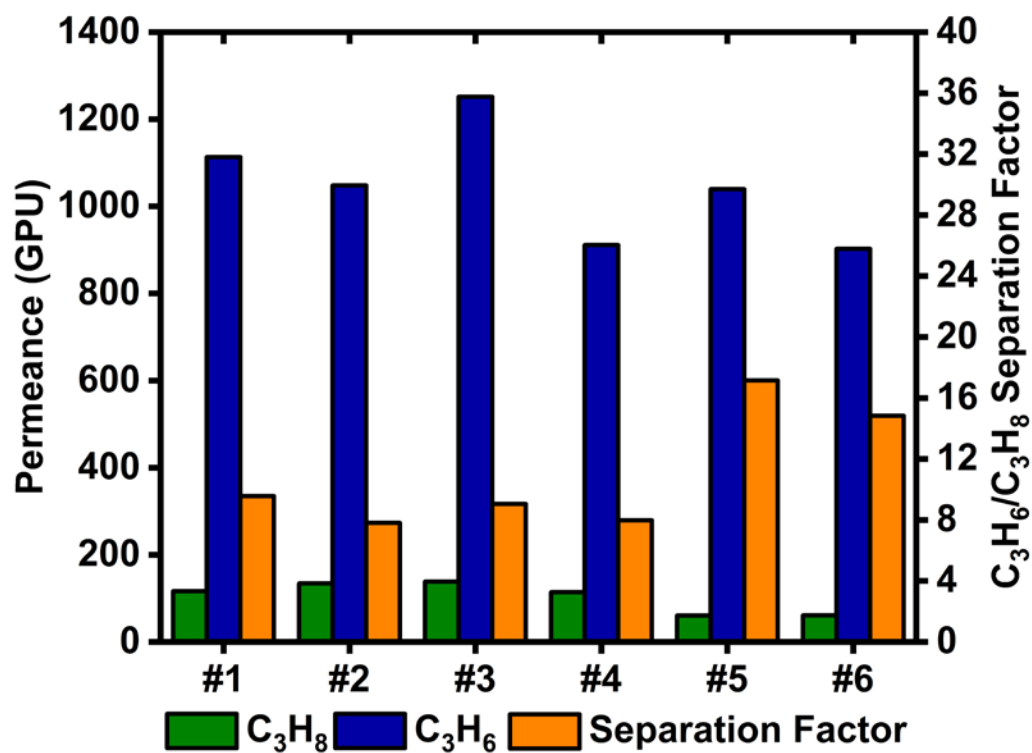
**Figure S20.** a) The photograph of micron-sized ZIF-8 grown on a piece of woven PET fabric without curli nanofiber coatings. The SEM images of b) top view and c) a zoomed-in PET fiber coated with ZIF-8.



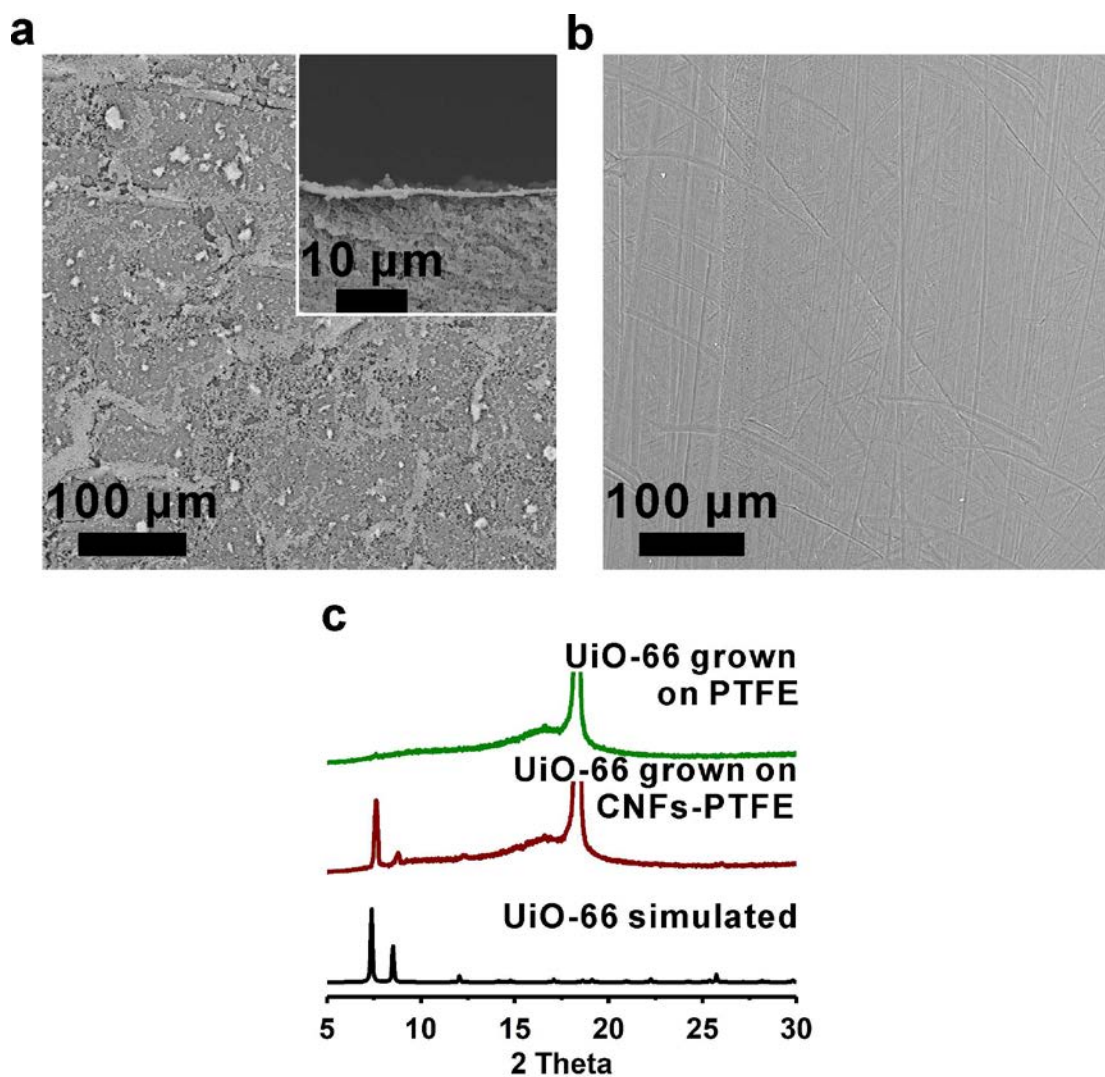
**Figure S21.** The high-resolution SEM images of a) ZIF-8@CNFs-PVDF obtained through layer-by-layer technique and b) the final TFC membrane with a PDMS coating.



**Figure S22.** Schematic home-built mixed-gas permeation device: 1) propane cylinder, 2) propylene cylinder, 3) helium cylinder, 4) mass flow controllers, 5) digital pressure gauge, 6) back pressure valve, 7) oven, 8) membrane cell, 9) GC



**Figure S23.** Binary equimolar  $C_3H_6/C_3H_8$  separation factor (right y axis) and permeance (left y axis) of six ZIF-8 TFC membrane samples.



**Figure S24.** SEM images of UiO-66 particles grown on a) CNFs-coated PTFE and b) bare PTFE. The inset in a) is the cross-section SEM image of the corresponding sample. c) PXRD curves of different PTFE samples after UiO-66 growth.

## References

1. J. Cravillon, R. Nayuk, S. Springer, A. Feldhoff, K. Huber and M. Wiebcke, *Chemistry of Materials*, 2011, **23**, 2130-2141.
2. J. E. Bachman, Z. P. Smith, T. Li, T. Xu and J. R. Long, *Nat. Mater.*, 2016, **15**, 845-849.