

## Three dimension modelling of the components in supercapacitors for proper understanding and contribution of each parameter to the final electrochemical performance

Farshad Barzegar <sup>\*a</sup>, Lijun Zhang <sup>a</sup>, Abdulhakeem Bello <sup>b,c</sup>, Ncholu Manyala <sup>b</sup>, Xiaohua Xia <sup>a</sup>

<sup>a</sup> Electrical, Electronic and Computer Engineering Department, University of Pretoria, Pretoria 0002, South Africa

<sup>b</sup> Physics Department, Institute of Applied Materials, SARCHI Chair in Carbon Technology and Materials, University of Pretoria, Pretoria 0028, South Africa

<sup>c</sup> Department of Materials Science and Engineering, African University of Science and Technology, Abuja, Nigeria

\*Corresponding Author Email address: [farshadbarzegar@gmail.com](mailto:farshadbarzegar@gmail.com)

\*The first two authors contributed equally to this work.

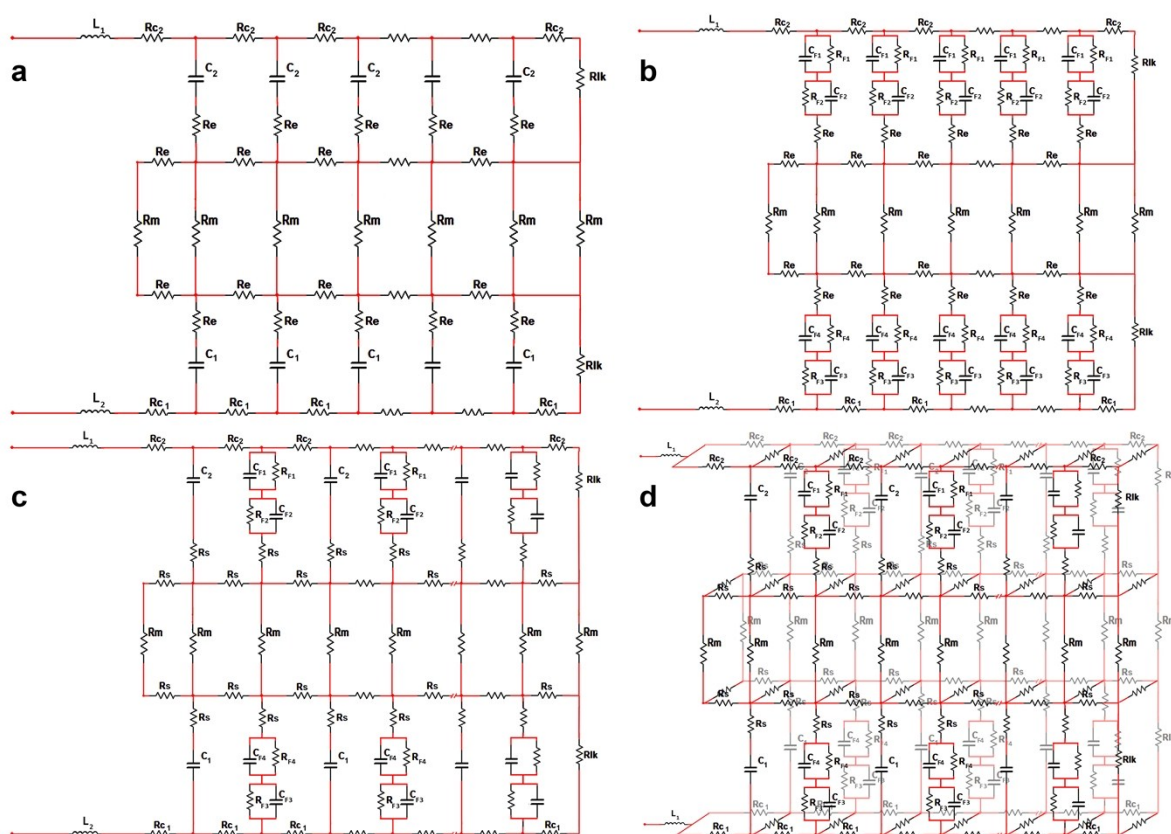

Figure S1. (a) 2D equivalent electrical model for full cell of the porous electrode in EDLCs, (b) RECs and, (c) Hybrid material and (d) 3D electrical equivalent model of practical ECs

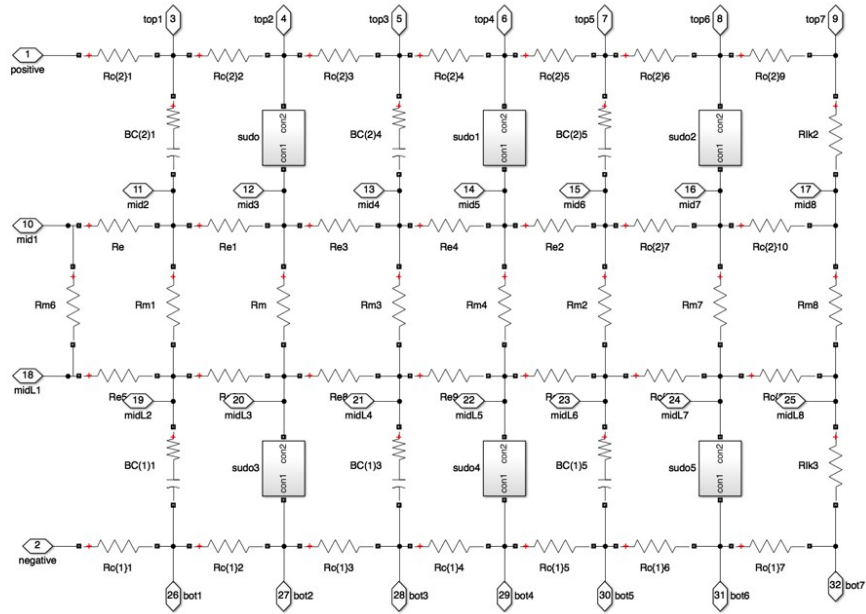

Figure S2. 2D supercapacitor model in Simulink

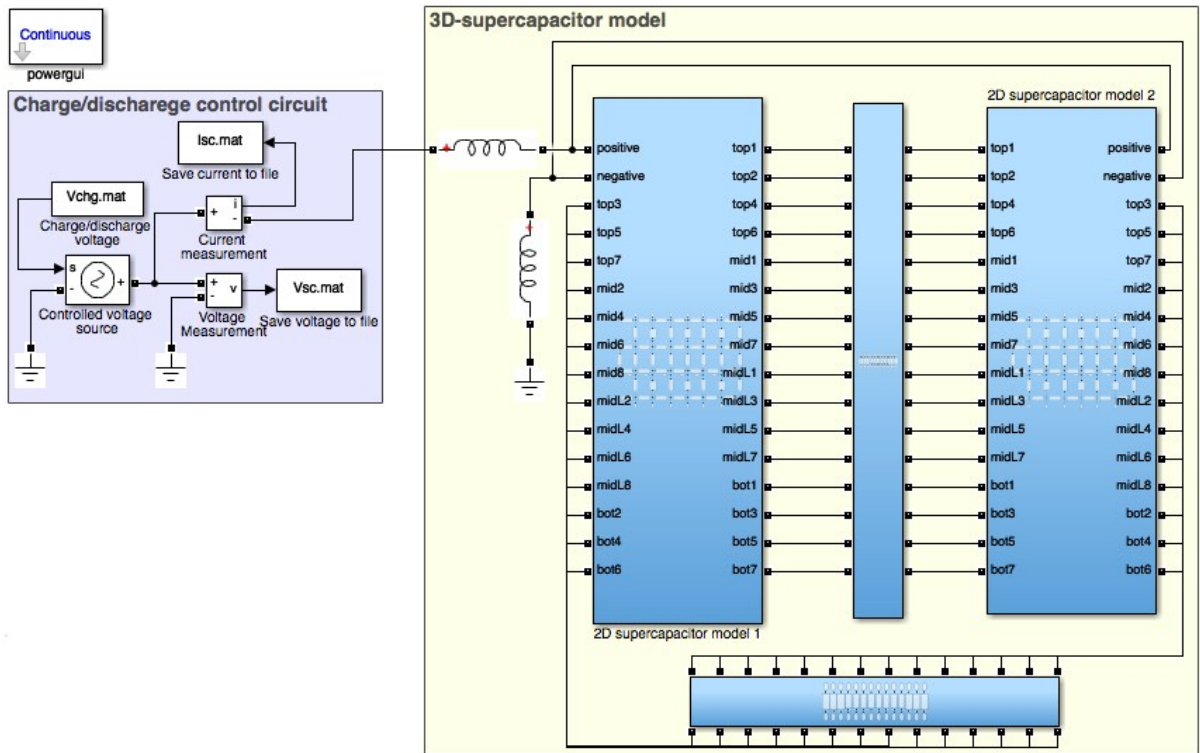

Figure S3. 3D Simulink model of the supercapacitor for simulation

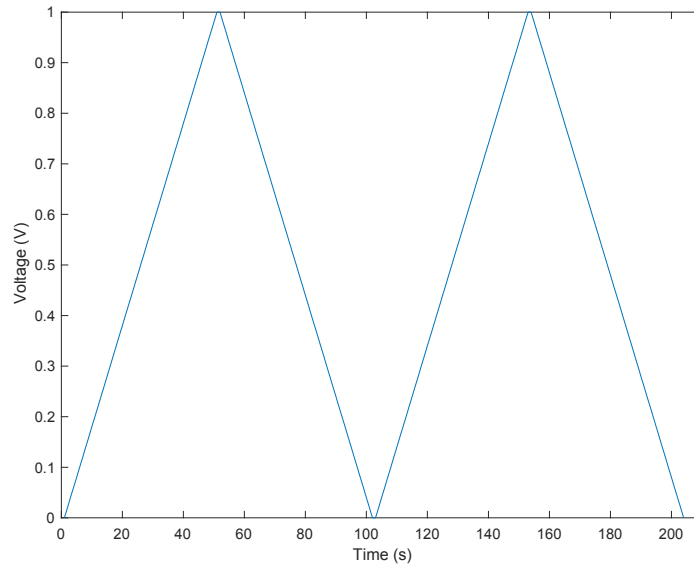

Figure S4. Saw tooth voltage charge/discharge waveform for the simulation cell performance

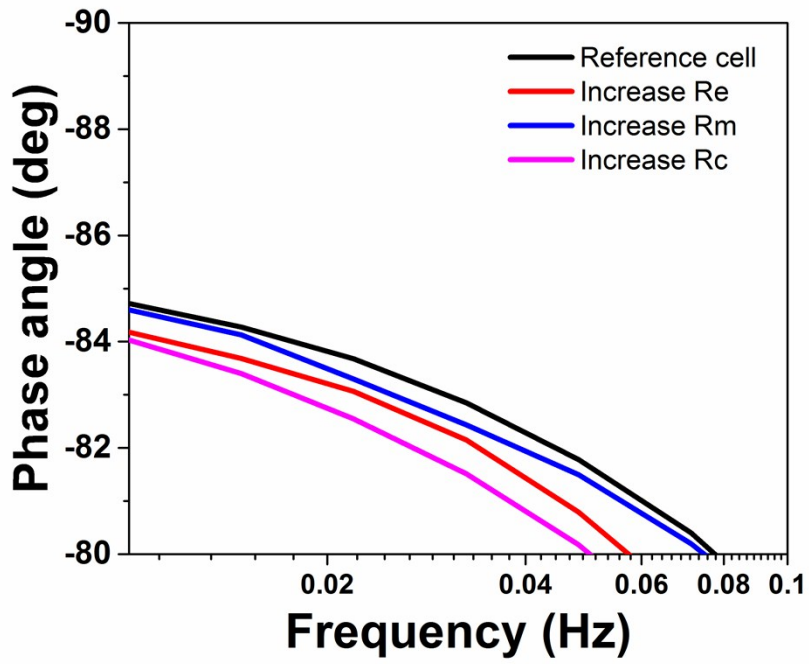

Figure S5. An enlarged view of the phase angle versus frequency in reality