

## Supporting Information

# Selective Ozone Activation of Phenanthrene in Liquid CO<sub>2</sub>

Honghong Shi,<sup>a</sup> Michael Lundin,<sup>a</sup> Andrew Danby,<sup>a</sup> Eden P. Go,<sup>c</sup> Abhimanyu Patil,<sup>d</sup>  
Huaxing Zhou,<sup>d</sup> Timothy A. Jackson,<sup>a,c</sup> and Bala Subramaniam,<sup>a,d,†</sup>

<sup>a</sup>Center for Environmentally Beneficial Catalysis, University of Kansas, Lawrence, KS  
66047

<sup>b</sup>ExxonMobil Research and Engineering Company, 1545 Rt 22 East, Annandale, New  
Jersey 08801

<sup>c</sup>Department of Chemistry, University of Kansas, Lawrence, KS 66045

<sup>d</sup>Department of Chemical and Petroleum Engineering, University of Kansas, Lawrence,  
KS 66045

† Corresponding author. Email: [bsubramaniam@ku.edu](mailto:bsubramaniam@ku.edu)

## Observation of phenanthrene's miscibility in liquid CO<sub>2</sub>

A schematic of the experimental setup for testing the solubility of phenanthrene in liquid CO<sub>2</sub> is shown in Figure S1. Liquid CO<sub>2</sub> is pumped into the reactor via an ISCO pump from a CO<sub>2</sub> cylinder with a dip tube (99.999%, research-grade, supplied by Matheson). The reactor uses a high-pressure cell (grade 4 titanium) equipped with an ultrasonic horn, pressure transducer, thermocouple, sampling and pressure relief valves. Reactor temperature and pressure are recorded continuously during the experiments using a National Instruments™ LabView interface. Temperature control is achieved with an insulated jacket surrounding the reactor vessel through which a coolant is circulated. The sapphire windows on the reactor cell allow the operator to view the reactor contents during an experiment.

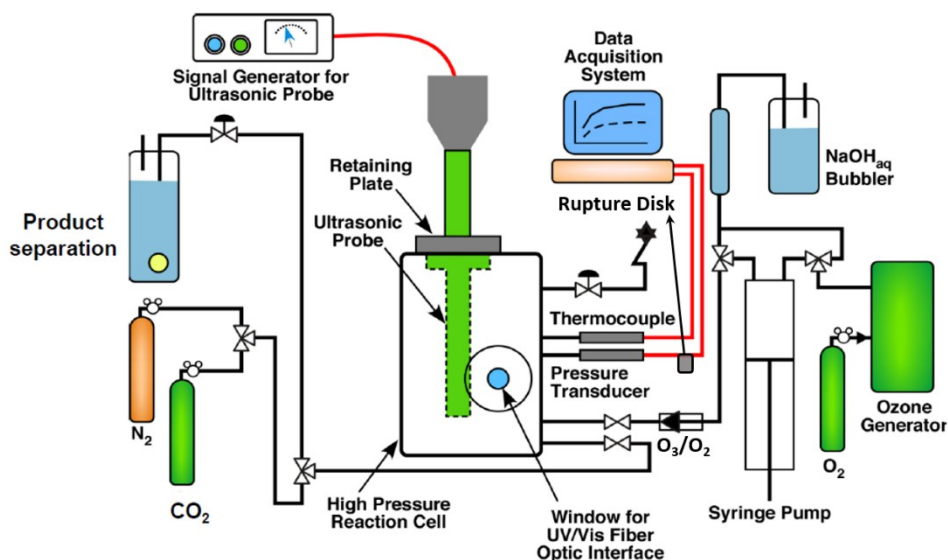
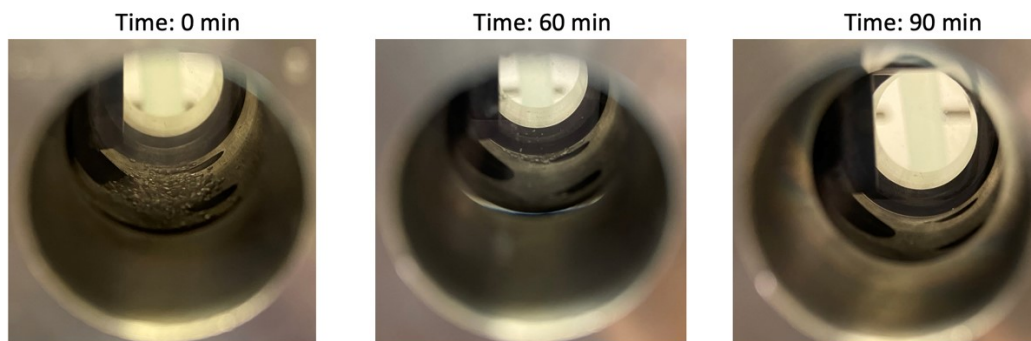

Figure S1. View-cell setup to observe miscibility of phenanthrene in liquid CO<sub>2</sub>

The dissolution of phenanthrene in liquid CO<sub>2</sub> was first investigated to determine its loading for homogeneous ozonation. Phenanthrene ranging from 0.1-0.5 g was mixed in 10 mL of liquid CO<sub>2</sub>, cooled to 8 °C. Sonication (amplitude of sonicator = 29-32%) was used for mixing. During sonication, the temperature of the cell contents increased to around 10 °C but decreased back to 8 °C after sonication was terminated. As shown in Figures S2

and S3, phenanthrene gradually dissolves in liquid CO<sub>2</sub> at these conditions: 0.2 g phenanthrene dissolves in 10 mL liquid CO<sub>2</sub> within 4 hours of continuous sonication.



**Figure S2. Dissolution of 0.1 g phenanthrene in 10 mL liquid CO<sub>2</sub> at 8 °C, 4.4 MPa**

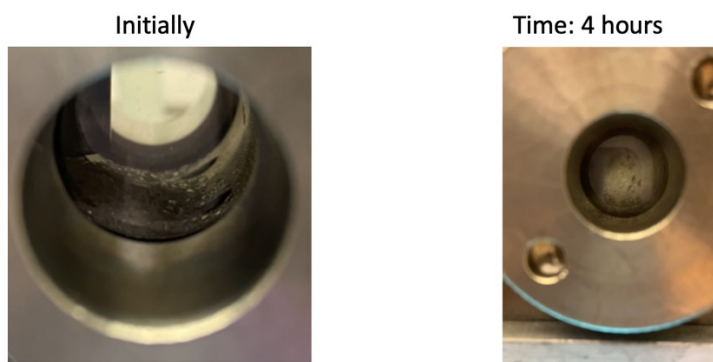

**Figure S3. Dissolution study of 0.5 g phenanthrene in 10 mL liquid CO<sub>2</sub> at 8 °C, 640 psi (not completely dissolved within 4 hours with sonication)**

## Reactor setup

The view-cell reactor in Figure S1 was replaced by a closed-cell reactor to perform the ozonolysis experiment. The main technical challenge is the determination and control of CO<sub>2</sub> liquid level in the opaque closed-cell reactor.

The level of liquid CO<sub>2</sub> in the cell,  $h$ , is estimated as

$$h = \frac{P}{\rho_{CO_2} \cdot g} - h_0$$

where  $P$  is the hydrostatic pressure as measured by the differential pressure transducer;  $\rho_{CO_2}$  is density of liquid CO<sub>2</sub> at the vessel temperature and pressure;  $g$  is the gravitational strength (9.8 N/kg);  $h_0$  is the reference height corresponding to differential pressure without the liquid CO<sub>2</sub>.

To validate the approach as described above, a differential pressure transducer purchased from the Validyne Engineering was used to measure the hydrostatic pressure of the liquid CO<sub>2</sub>. The measurements were performed in the view-cell first (as shown in Figure S4a) to validate the technical feasibility of using differential pressure transducer to determine the level of liquid CO<sub>2</sub>.

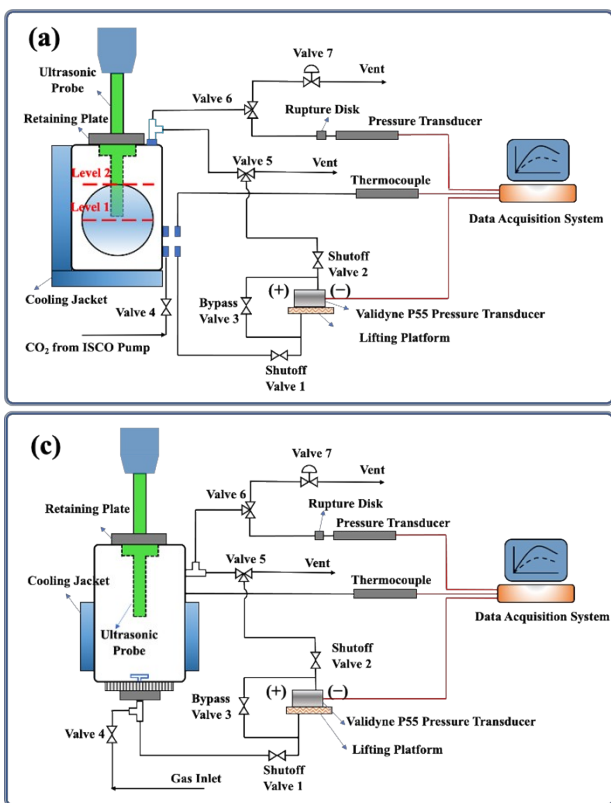

Figure S4. Schemes and pictures of reaction setup for determination of CO<sub>2</sub> liquid level (a) view-cell reactor; (c) closed-cell reactor

### Calculation of initial O<sub>3</sub>:phenanthrene molar ratio at 6.72 MPa and 8°C

Concentration of O<sub>3</sub> in O<sub>2</sub> is 2 mol% and the total pressure of O<sub>2</sub>/O<sub>3</sub> and CO<sub>2</sub> mixture in the reactor is 975 psi (67.2 bar or 6.72 MPa). Since the saturation pressure of liquid CO<sub>2</sub> at 8 °C is about 4.28 MPa<sup>1</sup>. The partial pressure of O<sub>3</sub> = (6.72-4.28) × 2 mol% = 0.0488 MPa. By Henry's Law<sup>2</sup>:

Concentration of O<sub>3</sub> in the liquid phase = 2.33 mol/L/MPa × 0.0488 MPa = 0.1137 mol/L

Volume of CO<sub>2</sub> liquid = 10 mL = 0.01 L

Molar quantity of O<sub>3</sub> in the liquid CO<sub>2</sub> phase = 0.0011 mol

Molar quantity of initial phenanthrene = 0.2 g / (178 g/mol) = 0.0011 mol

Therefore, the molar ratio under this condition is about 1:1.

## Ozonolysis experiment

In a typical experiment, 0.2 g phenanthrene was placed in the closed-cell as shown in Figure S4c, mixed with a predetermined volume of liquid CO<sub>2</sub> using the method as mentioned above, and cooled to 8 °C. The saturation vapor pressure of liquid CO<sub>2</sub> at 8 °C is approximately 4.4 MPa. Ozone was introduced into the vessel with an ISCO pump, whose cylinder was initially filled with an approximately 2 mol% O<sub>3</sub> in O<sub>2</sub> stream from the ozone generator at ambient pressure and room temperature. Following complete dissolution of phenanthrene under sonication (in approximately four hours), the O<sub>3</sub>/O<sub>2</sub> mixture in the ISCO pump was first compressed (by reducing the cylinder volume at 200 mL/min) to approximately 4.8 MPa, which is slightly greater than the saturation pressure of liquid CO<sub>2</sub> in the closed-cell maintained at 8 °C. The inlet valve to the closed-cell is then opened to gradually pump O<sub>3</sub>/O<sub>2</sub> mixture into the cell at 25 mL/min (which corresponds to the rate at which the ISCO pump cylinder volume is reduced). The slow pumping rate ensures a gradual pressure rise in the view cell to 6.72 MPa as it is filled with the O<sub>3</sub>/O<sub>2</sub> mixture and minimizes temperature rise upon gas compression in the cell volume. This pressurization step (after the inlet valve was opened) takes approximately 1.5 minutes and signals the start of the ozonation reaction. The partial pressure of O<sub>3</sub> corresponding to the total pressure of 6.72 MPa bar provides an O<sub>3</sub>:substrate molar ratio of approximately 1 in liquid CO<sub>2</sub> as mentioned above. In an oxidation experiment, an extremely short ultrasonic pulse (< 1 second) was used to get good mixing of O<sub>3</sub>/O<sub>2</sub> with the liquid CO<sub>2</sub> phase at the start of the reaction to overcome potential gas-liquid mass transfer limitations. The reaction was allowed to proceed for a known duration, following which the product mixture was worked up for analysis according to the procedure described in the following section.

### Safety

Even though the propensity for phenanthrene to spontaneously combust in a dense CO<sub>2</sub> atmosphere is low (as we have demonstrated in the experiments), the estimated pressure rise for total combustion of phenanthrene is approximately 230 bar. A pressure relief valve equipped with a diaphragm that ruptures when the pressure reaches 207 bar (burst rating as 3000 psig by manufacture) is therefore provided to avoid overpressures in case of

reaction runaway. Using as small an amount of phenanthrene as possible that permits easy recovery of products and sensitive product analysis while also preventing thermal runaway situations is preferred to promote inherent safety.

## **Product analysis**

Following a run, the closed-cell reactor was depressurized gradually (over approximately 30 minutes) at reactor temperature (8 °C) to avoid CO<sub>2</sub> freezing in the lines and minimize loss of volatile organic products. The closed cell was then opened and filled with 10 mL of either acetone or other organic solvents to collect the ozonolysis products. During the sample collection step, the view cell temperature was still maintained at 8 °C to minimize further reaction or decomposition involving the products. The product solution was analyzed by GC/MS and GC-FID by diluting 1 mL of the recovered product solution with 10 mL of acetone. The GC method uses an HP-INNOWAX column on an Agilent 7890A GC interfaced with a 5975C MS and uses a carrier gas flow of 1 std cm<sup>3</sup> min<sup>-1</sup>, an injector temperature of 250 °C, and an injection volume of 1 µL. The column oven temperature was initially held at 40 °C for 5 min, then ramped at 10 °C per minute to 220 °C and held at this temperature for a further 20 min. Masses were scanned from 20 to 500 Da.

The recovered product solution was also analyzed by HPLC (Shimadzu LC-20AT with SPD-20A dual-channel UV-vis detector) using a C18 column (Waters Spherisorb ODS-2, 5 µm, 4.6 mm x 250 mm) and a mixture of 80% organic phase+20% water as the mobile phase. The organic fraction of the mobile phase is a solution of 7:2 v/v CH<sub>3</sub>CN/CH<sub>3</sub>OH while the water phase contains 0.1 wt.% phosphoric acid.

In addition, an identical experiment at the higher initial ozone concentration was performed to collect product samples for NMR analysis. Following gas release, 2 mL of deuterated solvent (toluene-*d*<sub>8</sub>) was used for sample collection and subject to <sup>1</sup>H and 2D NMR analysis on a Bruker Avance AVIII 500 MHz spectrometer equipped with a multi-nuclear BBFO cryoprobe and a 60-position BACS sample changer. Auto phase correction and auto baseline correction were performed in MestReNova for the <sup>1</sup>H NMR spectra. Tetramethylsilane (TMS) is added to the deuterated solvents as an internal standard at 0 ppm for referencing. In the COSY and HMBC spectra, apodization using Sine Square 0.0

along both dimensions were performed. As for the HSQC, Sine Square 90.0 in both dimensions was used for apodization processing. Zero filling was also applied to all the 2D spectra using at least doubled data size to acquire better data quality.

Undissolved solid product was observed in the recovered acetone solutions from the experiments at both ozone concentrations. The undissolved product was separated in a centrifuge and was dissolved in 0.5 mL of tetrahydrofuran (THF) for matrix assisted laser desorption/ionization time-of-flight (MALDI-TOF) characterization. Samples were prepared by combining 3  $\mu$ L of the dissolved product, 3  $\mu$ L of 2,5-dihydrobenzoic acid (DHB, 20 mg/mL in THF), and 1  $\mu$ L of sodium trifluoroacetate (100  $\mu$ g/mL in THF) as cationizing agent in a PCR tube and then mixed thoroughly. One microliter of each of the resulting solution was spotted onto a stainless steel MALDI plate then dried before loading the plate into the Bruker Autoflex maX LRF MALDI-TOF mass spectrometer (Bruker Daltonics, Bellerica MA). MALDI data were acquired using the reflector-positive ion mode with the following acquisition parameters: an IS1 voltage of 19 kV, an IS2 voltage of 16.75 kV, a lens voltage of 8.4 kV, reflector 1 voltage of 21 kV, reflector 2 voltage of 9.6 kV, and a delay time of 120 nsec.

### **Determination of water formation**

Suspecting that the carbon deficit may be due to combustion of the substrate and/or products, an attempt was made to quantify water in the acetone cell wash of the products. Based on the stoichiometry of complete substrate combustion (5 mol of water formed per one mole of phenanthrene combustion), around 1.7 mmol of water as product would be expected assuming that the unaccounted carbon was present in phenanthrene ( $32\% \times 1.12 \text{ mmol} = 0.36 \text{ mmol}$ ) and was subject to complete combustion. With 20 mL of acetone solvent used for product collection, the corresponding water content was expected to be 0.13 wt.%.

The acetone solvent was (HPLC grade, >99.9%, Sigma Aldrich) pre-dried by storage of the acetone over 3Å molecular sieve for more than 24 h. The water content of dry acetone solvent is 0.00 wt.% as determined by volumetric Karl-Fisher titration. The ozonolysis experiment was repeated in the closed-cell reactor as described above. The collected 20



mL acetone cell wash was analyzed immediately with the Karl-Fischer apparatus for water determination. To account for absorption of moisture from ambient air during product collection, 20 mL of dry acetone in a dried vial was allowed to stand uncapped for equilibration with the ambient moisture. The dried solvent, control solvent and acetone cell wash were each analyzed thrice on the Karl-Fischer titrator.

**Table S1. Ozonolysis products identified by the GC/MS**

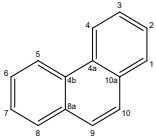
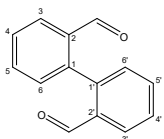
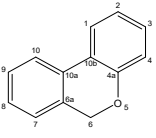
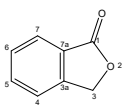
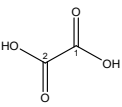
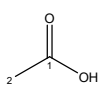
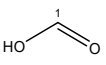
Name	Structure	Retention Time (min)
Phenanthrene		28.4
Biphenaldehyde		35.7
6H-Dibenzo[b,d]-pyran		26.2
1(3H)-isobenzofuranone		23.5
Oxalic acid		14.5
Acetic acid		13.6
Formic acid		15.5

Standard materials of phenanthrene and diphenaldehyde purchased from TCI America Inc. were used for confirmation of peaks in GC results.

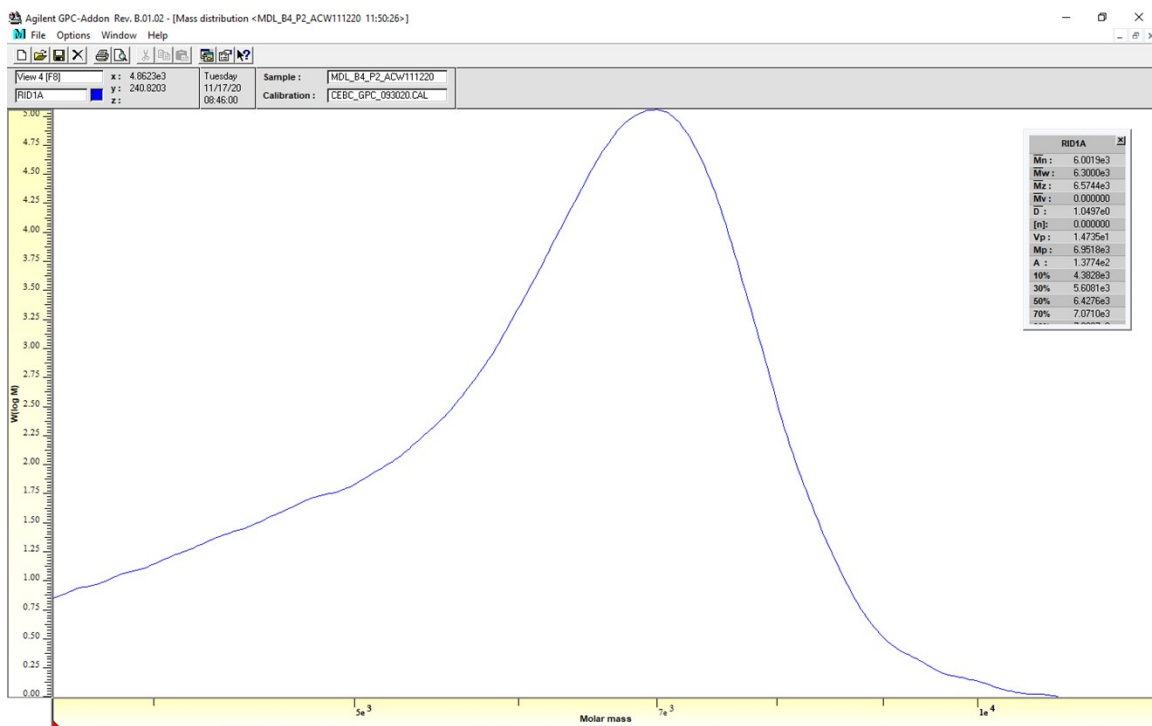

Figure S5. GPC analysis of the insoluble product (dissolved in DMF)

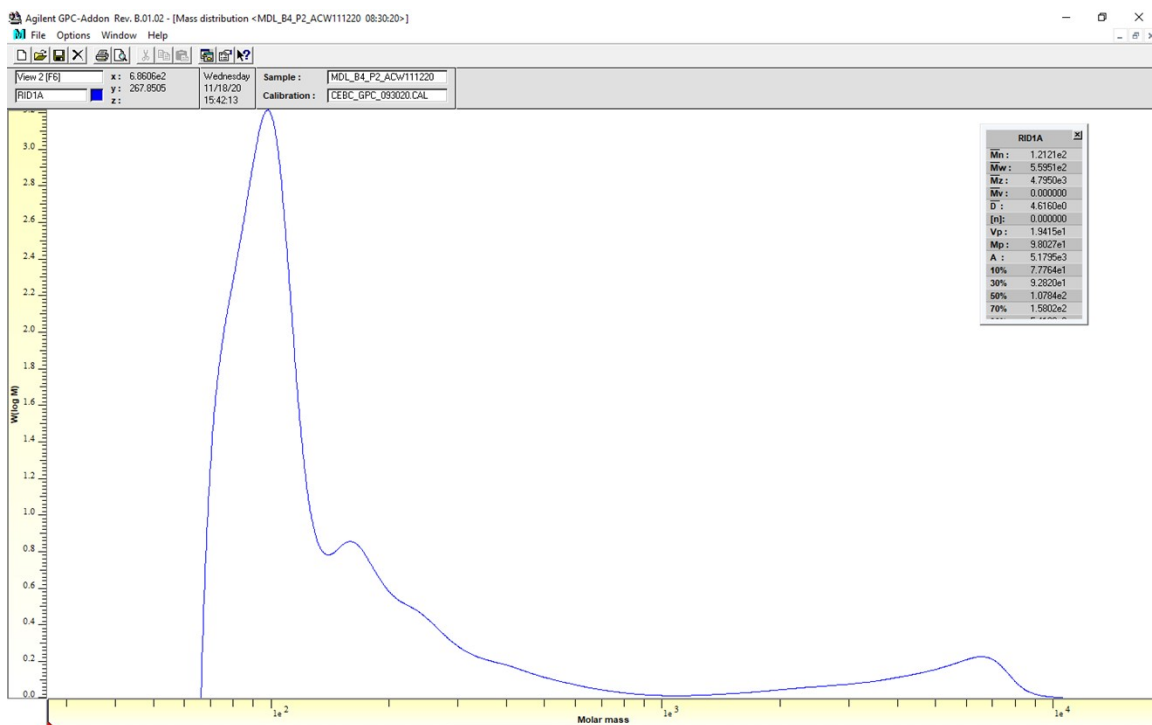
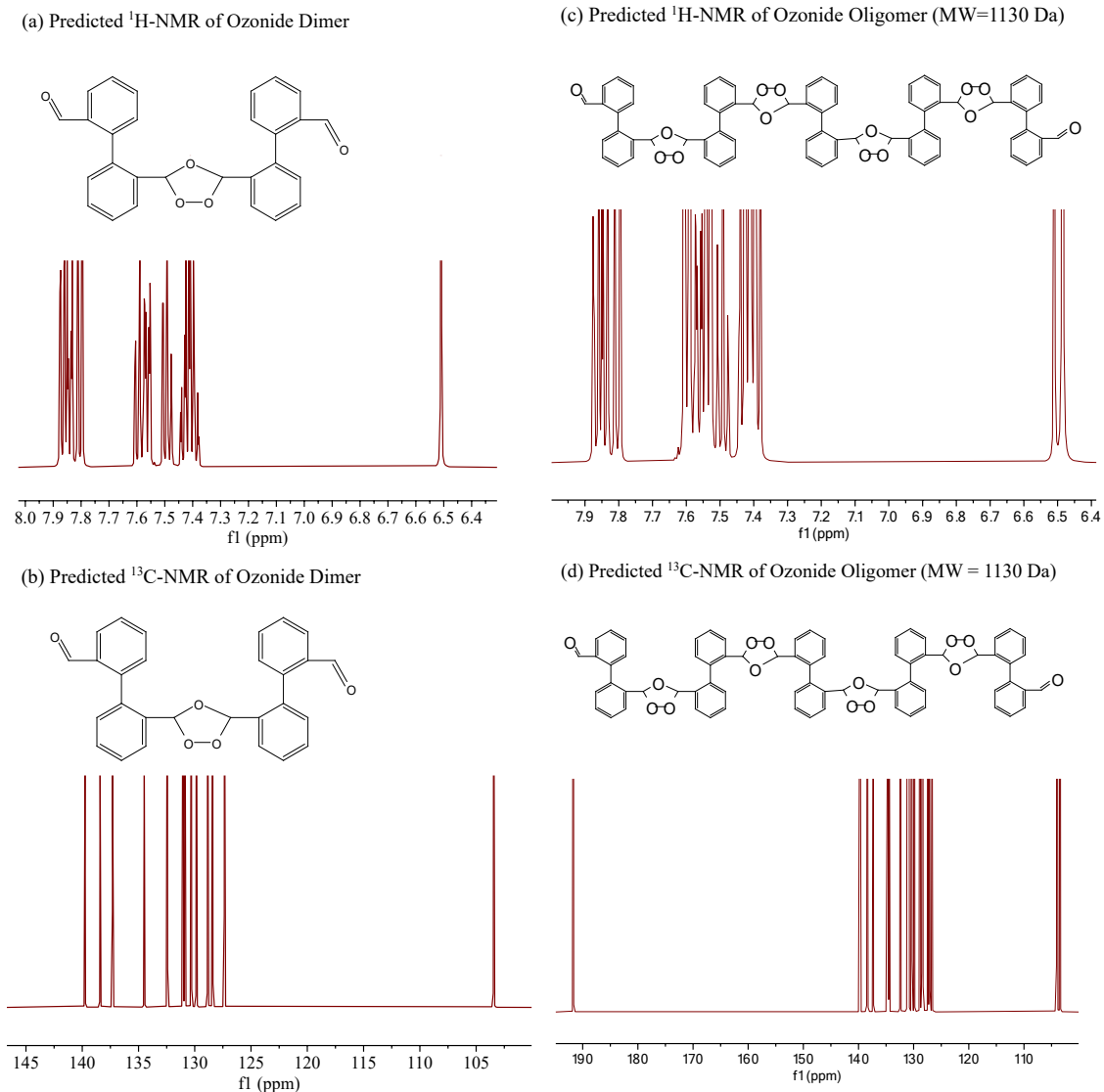

Figure S6. GPC analysis of the acetone cell wash solution

The GPC is calibrated based on polymethylmethacrylate (PMMA) standard. This may affect the accuracy of molecular weight estimation due to structural difference between



PMMA and reaction product.

**Figure S7. Predicted NMR spectra of ozonide dimer and oligomer**

(a)  $^1\text{H-NMR}$  of Ozonolysis Product  
(500 MHz, Toluene -  $d_8$ )

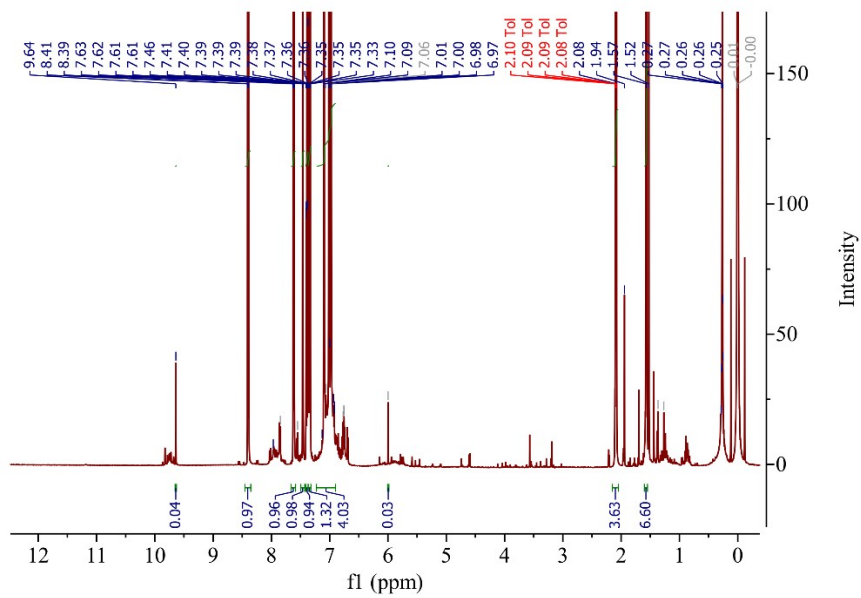

(b) 2D NMR Results - COSY

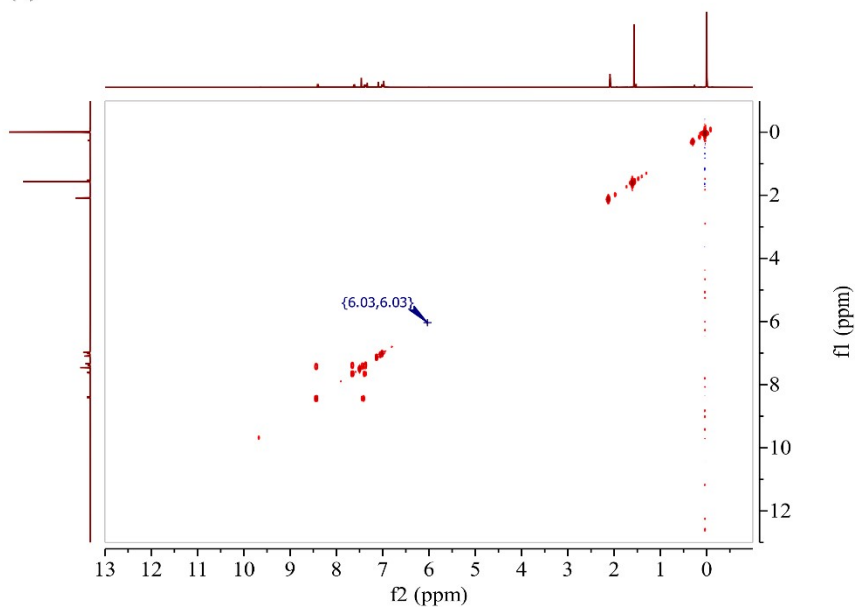

(d) 2D NMR Results - HMBC

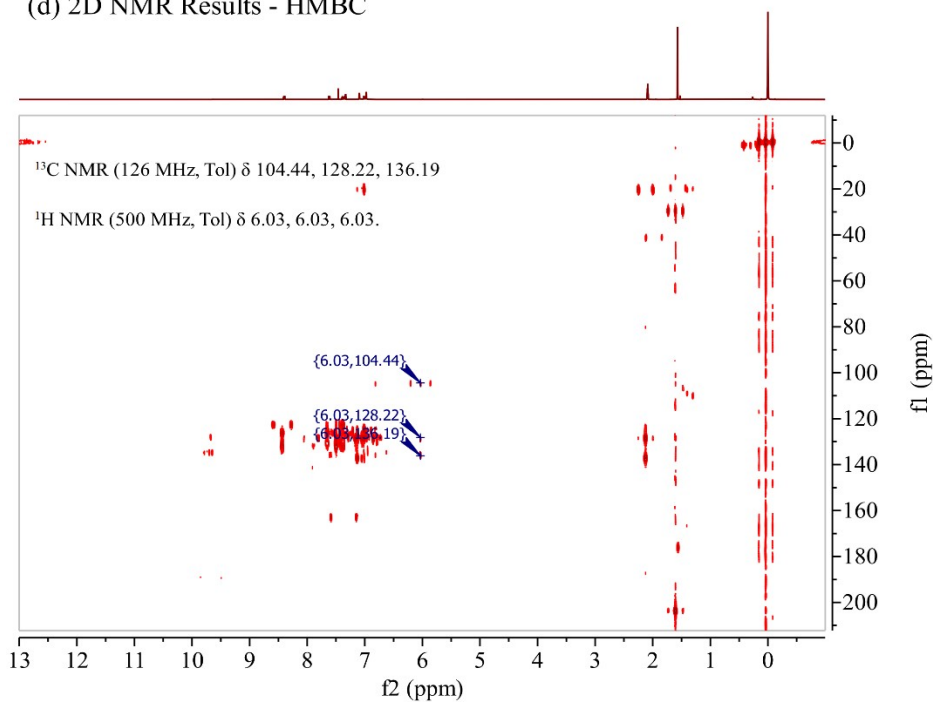

(c) 2D NMR Results - HSQC

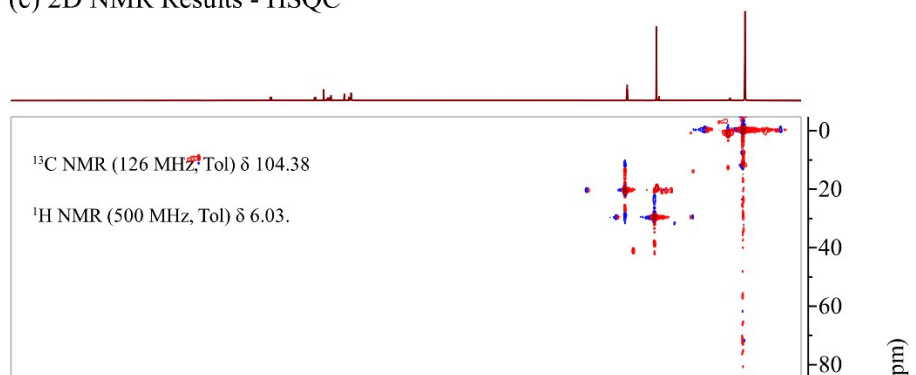

**Figure S8. Proton and 2D NMR results of ozonolysis products in toluene- $d_8$**

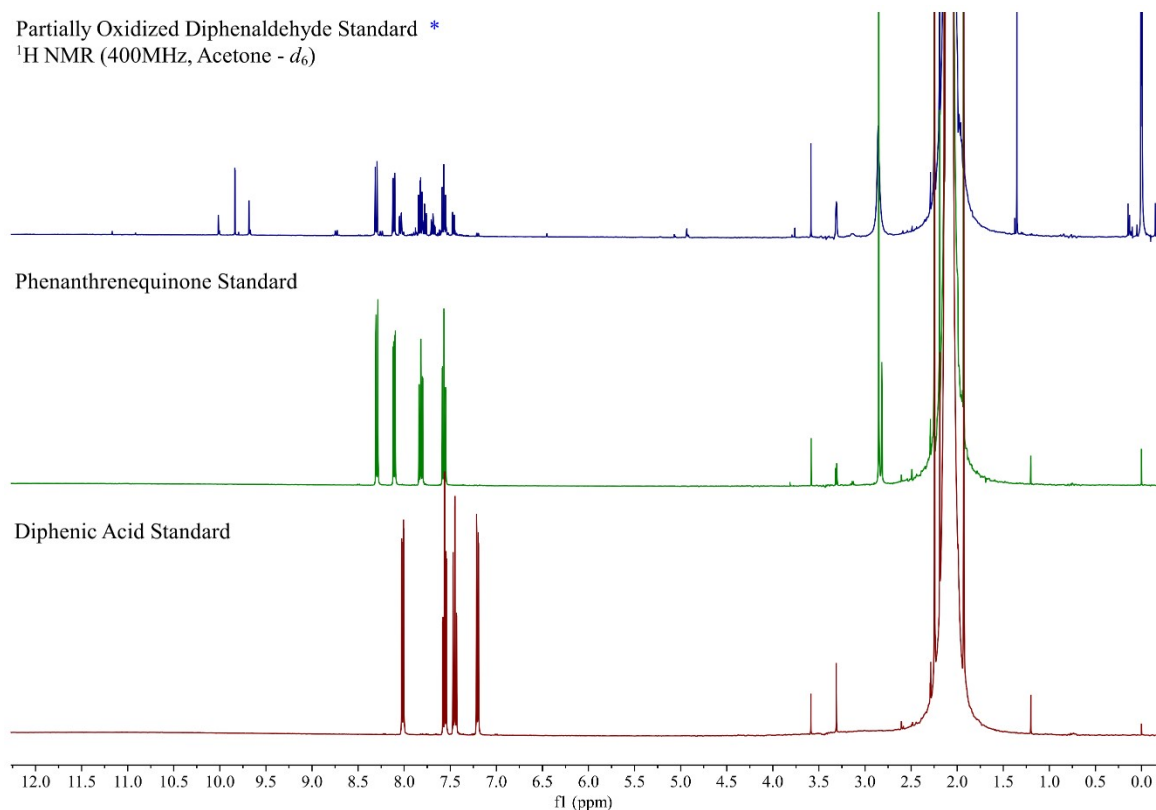

**Figure S9. Proton NMR results of diphenaldehyde, phenanthrenequinone and diphenic acid standards in acetone- $d_6$**

\*Diphenaldehyde was found unstable at room temperature in acetone solution. The standard sample was colorless upon preparation but turned to yellow in a few hours after NMR analysis.

## Author Contributions

H. Shi and M. Lundin carried out the ozonation experiments, HPLC, GC-FID, GC/MS and GPC analyses and moisture content measurement. A. Danby contributed to the reaction set-up development and solubility determination of PAH in liquid  $\text{CO}_2$ . E. Go performed the MALDI-TOF experiment and analysed the data. A. Patil and H. Zhou helped with the data interpretation and supervised the project. B. Subramaniam and T. Jackson designed and directed the project. All authors discussed the results and contributed to the final manuscript.

## References

1. R. Span and W. Wagner, *Journal of Physical and Chemical Reference Data*, 1996, **25**, 1509-1596.
2. M. D. Lundin, A. M. Danby, G. R. Akien, T. P. Binder, D. H. Busch and B. Subramaniam, *ACS Sustainable Chemistry & Engineering*, 2015, **3**, 3307-3314.