

Supplementary Information

7-Step Flow Synthesis of the anti-HBV Nucleoside Drug Entecavir

Zhenzhen Wang,^{†a} Yaling Li,^{†a} Guo-Tai Zhang,^a Xianjing Zheng,^{bc} Zhaowei Jiang,^a Pei Tang^{*a}
and Fen-Er Chen^{*abc}

^a *Key Laboratory of Drug-Targeting and Drug Delivery System of the Education Ministry and Sichuan Province, West China School of Pharmacy, Sichuan University, Chengdu 610041.*

E-mail: rfchen@fudan.edu.cn, peitang@scu.edu.cn

^b *Engineering Center of Catalysis and Synthesis for Chiral Molecules, Department of Chemistry, Fudan University, Shanghai 200433, China.*

^c *Shanghai Engineering Center of Industrial Asymmetric Catalysis for Chiral Drugs, Shanghai 200433, China.*

Table of contents

1. General Information	1
2. Experimental Procedures.....	2
3. The reaction equipment	12
4. References	13
5. NMR Spectra	14

1. General Information

All commercially available reagents were used without further purification. Tetrahydrofuran (THF) was distilled from sodium, Methanol (MeOH), N,N-Dimethylformamide (DMF) and Dichloromethane (DCM) was distilled from calcium hydride. Unless otherwise specified, all reagents and solvents were purchased from commercial sources and used as received. All new compounds were characterized by NMR spectroscopy, high resolution mass spectrometry (HRMS). ^1H (400 MHz) and ^{13}C (100 MHz) NMR were recorded on a Bruker Avance 400 spectrometer. Reference values for residual solvent were taken as $\delta = 7.26$ (CDCl_3) ppm, $\delta = 2.05$ (Acetone- d_6) ppm, $\delta = 2.50$ (DMSO- d_6) ppm for ^1H NMR and $\delta = 77.16$ (CDCl_3) ppm, $\delta = 2.05$ (Acetone- d_6) ppm, $\delta = 30.5/205.8$ (DMSO- d_6) ppm for ^{13}C NMR. Coupling constant (J) values are given in Hz. Multiplicities are designated by the following abbreviations: s, singlet; d, doublet; t, triplet; q, quartet; br, broad; m, multiplet. Products were purified by flash column chromatography on silica gel purchased from Qingdao Haiyang Chemical Co., Ltd. Optical rotations were measured by a Rudolph AUTOPOL I Automatic Polarimeter. HRMS were recorded on a Bruker microTOF spectrometer.

2. Experimental Procedure

Synthesis of compound 9

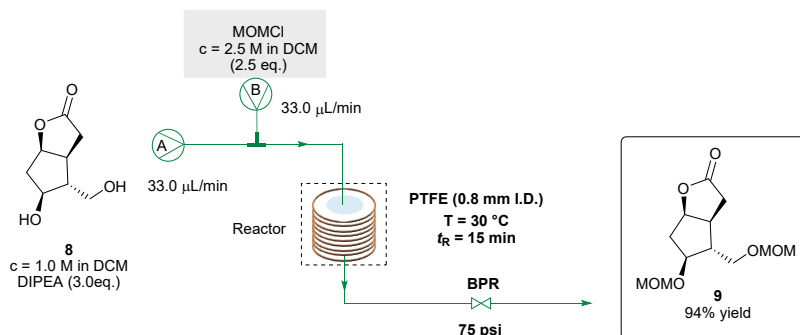

Table S1: The screening details for the synthesis of compound 9 ^a

Entry	t_R (min)	BPR (psi)	Temp. (°C)	Conv. (%) ^b
1	2	0	30	7
2	5	0	30	18
3	10	0	30	41
4	15	0	30	65
5	20	0	30	66
6	15	50	30	90
7	15	75	30	100 (94) ^c
8	15	75	20	95
9	15	75	40	100 (88) ^c

^aUnless otherwise specified, compound **8** (10.0 mmol) and diisopropylethylamine (30.0 mmol) were dissolved in anhydrous dichloromethane to afford a 1.0 M solution (10.0 mL), which was delivered via syringe pump A. While chloromethyl methyl ether (25.0 mmol) was dissolved in anhydrous dichloromethane to afford a 2.5 M solution (10.0 mL), which was delivered via syringe pump B; ^bThe conversion was determined by ¹H NMR spectroscopy using 1,1,2,2-tetrachloroethane as an internal standard; ^cIsolated yield.

A PTFE coil microflow reactor (i.d. 0.8 mm, length 200 cm, internal volume 1.0 mL) was used. Before the start of the actual experiment, the reactor was primed with DCM. Compound **8** (1.72 g, 10.0 mmol) and diisopropylethylamine (3.877 g, 30.0 mmol) were dissolved in anhydrous dichloromethane to afford a 1.0 M solution (10.0 mL), which was delivered via syringe pump A at a flow rate of 33 μL/min. Chloromethyl methyl ether (3.765 g, 25.0 mmol) was dissolved in anhydrous dichloromethane to afford a 2.5 M solution (10.0 mL), which was delivered via syringe pump B at the same flow rate. The two streams were mixed through a T-shaped mixer

and passed through the coil reactor at 30 °C with a residence time of 15 min under 75 psi back pressure. The system was allowed to come to steady state by waiting three residence times prior to collecting product, the output flow from the reactor was collected for 60 mins, quenched with saturated aqueous NaHCO₃, and extracted with DCM. The combined organic layers were dried over anhydrous Na₂SO₄, filtered, and concentrated under reduced pressure. Purification by flash column chromatography on silica gel (petroleum ether/EtOAc = 5:1) afforded compound **9** as a colorless oil (484.1 mg, 94% yield). $[\alpha]_D^{25} = +36.8$ (c = 0.66, CHCl₃). ¹H NMR (400 MHz, CDCl₃) δ 4.96 (m, 1H), 4.65-4.56 (m, 4H), 4.06-3.99 (m, 1H), 3.52-3.42 (m, 2H), 3.37-3.32 (m, 6H), 2.87-2.70 (m, 2H), 2.56 (dd, *J* = 17.2, 2.0 Hz, 1H), 2.32-2.12 (m, 3H). ¹³C NMR (100 MHz, CDCl₃) δ 177.0, 96.6, 95.6, 84.2, 79.7, 67.8, 55.6, 55.4, 52.7, 40.1, 38.3, 35.6. HRMS (ESI) *m/z* calcd for C₁₂H₂₀NaO₆ [M + Na]⁺: 283.1152, found: 283.1155. IR: 2917, 2825, 1765, 1213, 1147, 1103, 1024, 914 cm⁻¹.

Synthesis of compound **11**

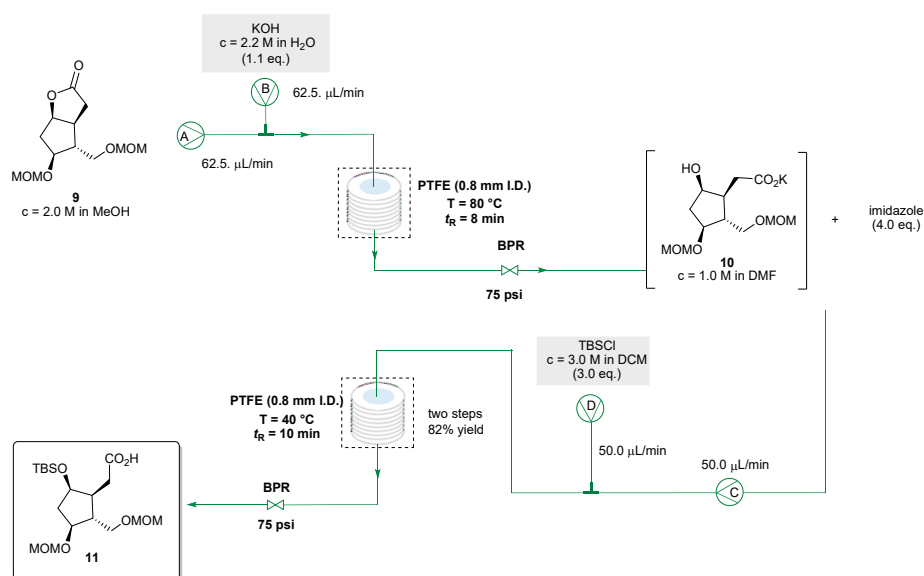

Table S2: The screening details for the synthesis of compound **10**^a

Entry	<i>t_r</i> (min)	BPR (psi)	Temp. (°C)	Conv. (%) ^b
1	2	0	70	11
2	3.33	0	70	35
3	5	0	70	62
4	8	0	70	70
5	8	50	70	82
6	8	75	70	93

7	8	100	70	95
8	8	75	80	100

^aUnless otherwise specified, compound **9** (10.0 mmol) was dissolved in methyl alcohol was dissolved in MeOH to afford a 2.0 M solution (5.0 mL), which was delivered via syringe pump A. While potassium hydroxide (11.0 mmol) was dissolved in water to afford a 2.2 M aqueous solution (5.0 mL), which was delivered via syringe pump B; ^bThe conversion was determined by ¹H NMR spectroscopy using 1,1,2,2-tetrachloroethane as an internal standard;

A PTFE coil microflow reactor (i.d. 0.8 mm, length 200 cm, internal volume 1.0 mL) was used. Compound **9** (2.6 g, 10.0 mmol) was dissolved in MeOH to afford a 2.0 M solution (5.0 mL), which was delivered via syringe pump A at a flow rate of 62.5 μ L/min. while KOH (616 mg, 11.0 mmol) was dissolved in H₂O to afford a 2.2 M aqueous solution (5.0 mL), which was delivered via syringe pump B at the same flow rate. The two streams were mixed through a T-shaped mixer and passed through the coil reactor at 80 °C with a residence time of 8 min under 75 psi back pressure. The system was allowed to come to steady state by waiting three residence times prior to collecting product, the output flow from the reactor was collected for 30 mins. The output of the reaction mixture was concentrated in vacuo to afford crude intermediate **10**, which was used directly in the next step.

Table S3: The screening details for the synthesis of compound **11** ^a

Entry	t _R (min)	BPR (psi)	Temp. (°C)	Conv. (%) ^b
1	2	0	30	10
2	2.5	0	30	17
3	5	0	30	31
4	10	0	30	51
5	12.5	0	30	52
6	10	50	30	74
7	10	75	30	85
8	10	100	30	87
9	10	75	40	100 (82) ^c

^aUnless otherwise specified, compound **10** (10.0 mmol) and imidazole (40.0 mmol) were dissolved in N,N-dimethylformamide to afford a 1.0 M solution (10.0 mL), which was delivered via syringe pump C. While tert-butyldimethylsilyl chloride (30.0 mmol) was dissolved in dichloromethane to afford a 3.0 M solution (10.0 mL), which was delivered via syringe pump D; ^bThe conversion was determined by ¹H NMR

spectroscopy using 1,1,2,2-tetrachloroethane as an internal standard; ^c Isolated yield over two steps.

A PTFE coil microflow reactor (i.d. 0.8 mm, length 200 cm, internal volume 1.0 mL) was used. Crude **10** (10.0 mmol) and imidazole (2.72 g, 40.0 mmol) were dissolved in anhydrous DMF to afford a 1.0 M solution (10.0 mL), which was delivered via syringe pump C at a flow rate of 50 $\mu\text{L}/\text{min}$. While TBDMSCl (4.52 g, 30.0 mmol) was dissolved in anhydrous CH_2Cl_2 to afford a 3.0 M solution (10.0 mL), which was delivered via syringe pump D at the same flow rate. The two streams were mixed through a T-shaped mixer and passed through the coil reactor at 40 $^\circ\text{C}$ with a residence time of 10 min under 75 psi back pressure. The system was allowed to come to steady state by waiting three residence times prior to collecting product, the output flow from the reactor was collected for 60 mins. The output of the reaction mixture was quenched with water, and extracted with EtOAc. The combined organic layers were washed with brine, dried over anhydrous Na_2SO_4 , filtered, and concentrated under reduced pressure. Purification by flash column chromatography on silica gel (petroleum ether/EtOAc = 5:1) afforded compound **11** as a colorless oil (3.22 g, 82% yield in two steps). $[\alpha]_{\text{D}}^{25} = -11.6$ ($c = 0.68$, CHCl_3). ^1H NMR (400 MHz, Acetone- d_6) δ 10.36 (s, 1H), 4.57-4.47 (m, 4H), 4.28-4.21 (m, 1H), 3.94-3.85 (m, 1H), 3.60-3.47 (m, 2H), 3.26-3.19 (m, 6H), 2.53 (dd, $J = 16.8, 9.6$ Hz, 1H), 2.38 (dd, $J = 16.8, 4.4$ Hz, 1H), 2.19-2.02 (m, 2H), 2.01-1.92 (m, 2H), 1.62 (m, 1H), 0.83 (s, 9H), 0.00 (s, 3H), -0.03 (s, 3H). ^{13}C NMR (100 MHz, Acetone- d_6) δ 174.6, 97.3, 96.6, 79.2, 73.7, 67.8, 55.4, 55.3, 50.1, 43.2, 42.1, 33.0, 26.4, 18.8, -4.2, -4.8. HRMS (ESI) m/z calcd for $\text{C}_{18}\text{H}_{36}\text{NaO}_7\text{Si}$ [$\text{M} + \text{Na}$] $^+$: 415.2123, found: 415.2127. IR: 2930, 2886, 2857, 1717, 1472, 1252, 1149, 1110, 1036, 918, 830, 775, 669 cm^{-1} .

Optimization conditions of photocatalytic dehydrogenative decarboxyolefination in batch for the synthesis of compound **12**

First, we attempted the optimal reaction conditions reported in the literature.^{1,2} When using the catalytic system of $\text{Ir}[\text{dF}(\text{CF}_3)\text{ppy}]_2(\text{dtbpy})\text{PF}_6$ and $\text{Co}(\text{dmgH})_2(4\text{-OMe-Py})\text{Cl}$, the target olefin product **12** could be obtained with a 52% separation yield. However, in the case of the $\text{Co}(\text{dmgH})_2\text{PyCl}$ and acridine catalytic system, almost no target product was produced. Based on this, we optimized the reaction conditions using the iridium/cobalt catalytic system as the base.

Table S4: Optimization conditions of photocatalytic dehydrogenative decarboxyolefination of compound 11 in batch.^a

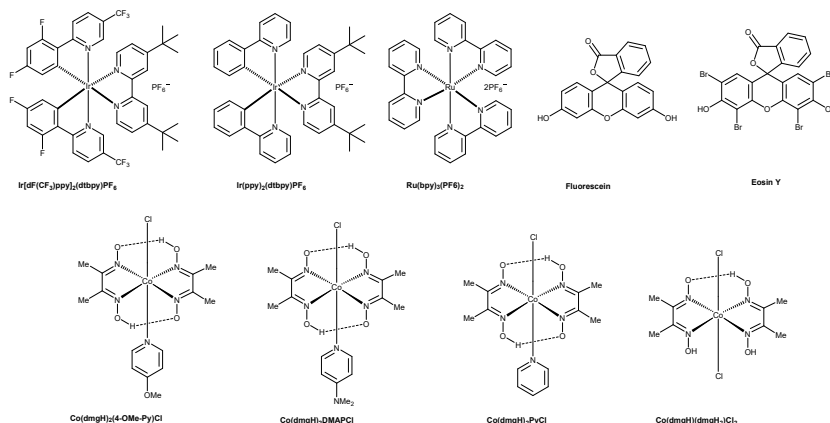
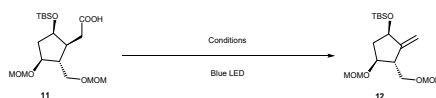

Entry	Photocatalyst	[Co]	Base	Solvent	Yield(%)
1	Ir[dF(CF ₃)ppy] ₂ (dtbbpy)PF ₆	Co(dmgh) ₂ (4-OMe-Py)Cl	Cs ₂ CO ₃ (20 mol%)	DME/H ₂ O = 18:1	52
2	/	Co(dmgh) ₂ PyCl	Acridine (20 mol%)	DCM/MeCN = 2:1	Trace
3	Ru(bpy) ₃ (PF ₆) ₂	Co(dmgh) ₂ (4-OMe-Py)Cl	Cs ₂ CO ₃ (20 mol%)	DME/H ₂ O = 18:1	NR
4	Ir(ppy) ₂ (dtbbpy)PF ₆	Co(dmgh) ₂ (4-OMe-Py)Cl	Cs ₂ CO ₃ (20 mol%)	DME/H ₂ O = 18:1	19
5	Fluorescein	Co(dmgh) ₂ (4-OMe-Py)Cl	Cs ₂ CO ₃ (20 mol%)	DME/H ₂ O = 18:1	NR
6	Eosin Y	Co(dmgh) ₂ (4-OMe-Py)Cl	Cs ₂ CO ₃ (20 mol%)	DME/H ₂ O = 18:1	NR
7	Ir[dF(CF ₃)ppy] ₂ (dtbbpy)PF ₆	Co(dmgh) ₂ PyCl	Cs ₂ CO ₃ (20 mol%)	DME/H ₂ O = 18:1	12
8	Ir[dF(CF ₃)ppy] ₂ (dtbbpy)PF ₆	Co(dmgh) ₂ DMAPCl	Cs ₂ CO ₃ (20 mol%)	DME/H ₂ O = 18:1	8
9	Ir[dF(CF ₃)ppy] ₂ (dtbbpy)PF ₆	Co(dmgh)(dmgh) ₂ Cl ₂	Cs ₂ CO ₃ (20 mol%)	DME/H ₂ O = 18:1	24
10	Ir[dF(CF ₃)ppy] ₂ (dtbbpy)PF ₆	Co(dmgh) ₂ (4-OMe-Py)Cl	Cs ₂ CO ₃ (50 mol%)	DME/H ₂ O = 18:1	63
11	Ir[dF(CF ₃)ppy] ₂ (dtbbpy)PF ₆	Co(dmgh) ₂ (4-OMe-Py)Cl	Cs ₂ CO ₃ (1.0 eq.)	DME/H ₂ O = 18:1	73
12	Ir[dF(CF ₃)ppy] ₂ (dtbbpy)PF ₆	Co(dmgh) ₂ (4-OMe-Py)Cl	Cs ₂ CO ₃ (1.5 eq.)	DME/H ₂ O = 18:1	69
13	Ir[dF(CF ₃)ppy] ₂ (dtbbpy)PF ₆	Co(dmgh) ₂ (4-OMe-Py)Cl	KH ₂ PO ₄ (1.0 eq.)	DME/H ₂ O = 18:1	10
14	Ir[dF(CF ₃)ppy] ₂ (dtbbpy)PF ₆	Co(dmgh) ₂ (4-OMe-Py)Cl	K ₂ HPO ₄ (1.0 eq.)	DME/H ₂ O = 18:1	16
15	Ir[dF(CF ₃)ppy] ₂ (dtbbpy)PF ₆	Co(dmgh) ₂ (4-OMe-Py)Cl	K ₂ CO ₃ (1.0 eq.)	DME/H ₂ O = 18:1	26

16	$\text{Ir}[\text{dF}(\text{CF}_3)\text{ppy}]_2(\text{dtbpy})\text{PF}_6$	$\text{Co}(\text{dmgH})_2(4\text{-OMe-Py})\text{Cl}$	NaHCO_3 (1.0 eq.)	$\text{DME}/\text{H}_2\text{O} = 18:1$	11
17	$\text{Ir}[\text{dF}(\text{CF}_3)\text{ppy}]_2(\text{dtbpy})\text{PF}_6$	$\text{Co}(\text{dmgH})_2(4\text{-OMe-Py})\text{Cl}$	DBU (1.0 eq.)	$\text{DME}/\text{H}_2\text{O} = 18:1$	7
18	$\text{Ir}[\text{dF}(\text{CF}_3)\text{ppy}]_2(\text{dtbpy})\text{PF}_6$	$\text{Co}(\text{dmgH})_2(4\text{-OMe-Py})\text{Cl}$	Et_3N (1.0 eq.)	$\text{DME}/\text{H}_2\text{O} = 18:1$	10
19	$\text{Ir}[\text{dF}(\text{CF}_3)\text{ppy}]_2(\text{dtbpy})\text{PF}_6$	$\text{Co}(\text{dmgH})_2(4\text{-OMe-Py})\text{Cl}$	Cs_2CO_3 (1.0 eq.)	$\text{Dioxane}/\text{H}_2\text{O} = 18:1$	27
20	$\text{Ir}[\text{dF}(\text{CF}_3)\text{ppy}]_2(\text{dtbpy})\text{PF}_6$	$\text{Co}(\text{dmgH})_2(4\text{-OMe-Py})\text{Cl}$	Cs_2CO_3 (1.0 eq.)	$\text{THF}/\text{H}_2\text{O} = 18:1$	19
21	$\text{Ir}[\text{dF}(\text{CF}_3)\text{ppy}]_2(\text{dtbpy})\text{PF}_6$	$\text{Co}(\text{dmgH})_2(4\text{-OMe-Py})\text{Cl}$	Cs_2CO_3 (1.0 eq.)	$\text{Toluene}/\text{H}_2\text{O} = 18:1$	6
22	$\text{Ir}[\text{dF}(\text{CF}_3)\text{ppy}]_2(\text{dtbpy})\text{PF}_6$	$\text{Co}(\text{dmgH})_2(4\text{-OMe-Py})\text{Cl}$	Cs_2CO_3 (1.0 eq.)	$\text{DCE}/\text{H}_2\text{O} = 18:1$	Trace
23	$\text{Ir}[\text{dF}(\text{CF}_3)\text{ppy}]_2(\text{dtbpy})\text{PF}_6$	$\text{Co}(\text{dmgH})_2(4\text{-OMe-Py})\text{Cl}$	Cs_2CO_3 (1.0 eq.)	$\text{DME}/\text{H}_2\text{O} = 10:1$	52

General procedure: Under an N_2 atmosphere, a 5 mL reaction tube was charged with carboxylic acid **11** (0.1 mmol), $\text{Ir}[\text{dF}(\text{CF}_3)\text{ppy}]_2(\text{dtbpy})\text{PF}_6$ (0.01 mmol, 1 mol%), $\text{Co}(\text{dmgH})_2(4\text{-OMe-Py})\text{Cl}$ (0.005 mmol, 5 mol%), base, solvent (1.0 mL), and H_2O (56 μL). The reaction mixture was stirred under irradiation with 455nm blue LEDs (20 W) for 24 h at 35 °C (fan cooling). The mixture was concentrated under reduced pressure, and purification by flash column chromatography on silica gel (petroleum ether/ $\text{EtOAc} = 15:1$) afforded compound **12**.

General procedure of photocatalytic dehydrogenative decarboxyolefination under continuous flow for the synthesis of compound **12**

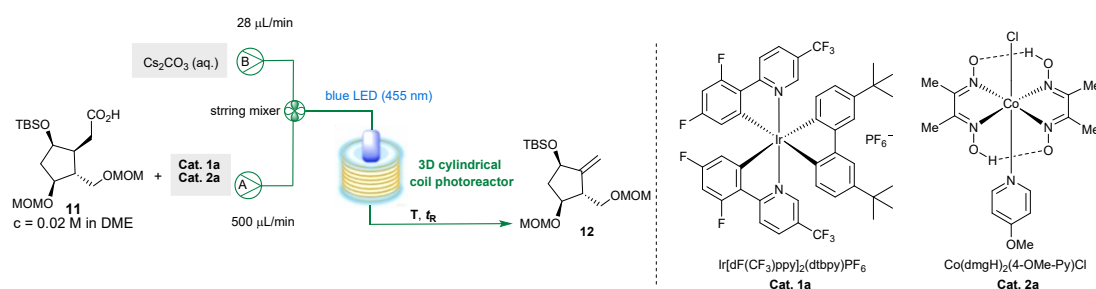

A PTFE coil microflow reactor (i.d. 1.6 mm, length 1350 cm, internal volume 27.1 mL) was used. Compound **11** (784.0 mg, 2.0 mmol), **Cat. 1a** (22.4 mg, 0.02 mmol), **Cat. 2a** (43.4 mg, 0.1 mmol) were dissolved in anhydrous DME to afford a 0.02 M solution (100.0 mL), which was delivered via syringe pump A at a flow rate of 500 $\mu\text{L}/\text{min}$, while Cs_2CO_3 (1.3 g, 4.0 mmol) was dissolved in H_2O to afford a 0.72 M aqueous solution (5.6 mL), which was delivered via syringe pump B at a flow rate of 28 $\mu\text{L}/\text{min}$. The two streams were mixed through a stirring mixer and passed through the coil reactor at 30 °C with a residence time of 51 min irradiated with a 20 W blue LED (455nm).

The system was allowed to come to steady state by waiting three residence times prior to collecting product, the output flow from the reactor was collected for 60 mins. The collected reaction mixture was concentrated under reduced pressure. Purification by flash column chromatography on silica gel (petroleum ether/EtOAc = 5:1) afforded compound **12** as a colorless oil (157.8 mg, 76% yield). $[\alpha]_D^{25} = -62.4$ (c = 0.90, CHCl₃). ¹H NMR (400 MHz, CDCl₃) δ 5.17 (m, 1H), 5.07-5.03 (m, 1H), 4.67 (d, J = 1.6 Hz, 2H), 4.62 (d, J = 1.6 Hz, 2H), 4.42-4.35 (m, 1H), 3.94 (m, 1H), 3.70-3.59 (m, 2H), 3.37 (s, 3H), 3.35 (s, 3H), 2.79-2.73 (m, 1H), 2.42 (m, 1H), 1.68-1.58 (m, 1H), 0.92 (s, 9H), 0.10 (s, 3H), 0.08 (s, 3H). ¹³C NMR (100 MHz, CDCl₃) δ 152.8, 107.8, 96.7, 95.9, 75.6, 72.7, 68.9, 55.5, 55.4, 49.0, 41.5, 26.0, 18.4, -4.5, -4.7. HRMS (ESI) m/z calcd for C₁₇H₃₄NaO₅Si [M + Na]⁺: 369.2068, found: 369.2069. IR: 2926, 2855, 1464, 1377, 1251, 1147, 1105, 1036, 835, 775 cm⁻¹.

Synthesis of compound **13**

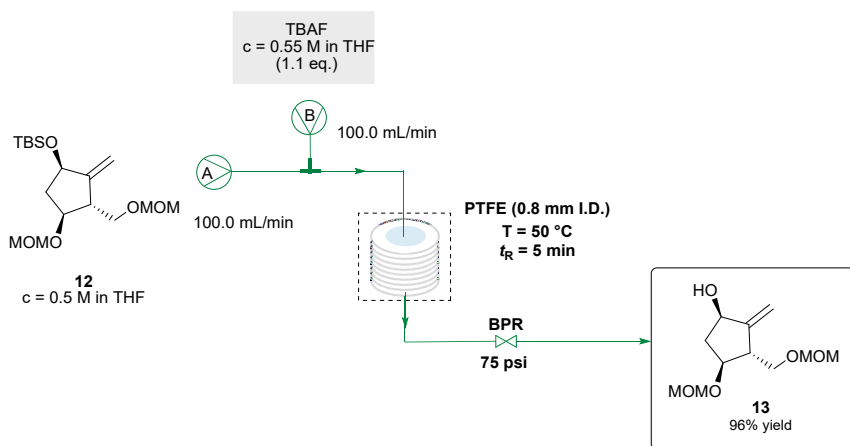

Table S5 The screening details for the synthesis of compound **13**^a

Entry	t_R (min)	BPR (psi)	Temp. (°C)	Conv. (%) ^b
1	2.5	0	30	26
2	3.33	0	30	35
3	5	0	30	41
4	10	0	30	42
5	5	50	30	78
6	5	75	30	85
7	5	100	30	87
8	5	75	40	95
9	5	75	50	100 (96) ^c

^aUnless otherwise specified, compound **12** (5.0 mmol) was dissolved in anhydrous tetrahydrofuran to afford a 0.5 M solution (10.0 mL), which was delivered via in syringe pump A. While tetrabutylammonium fluoride (5.5 mmol) was dissolved in anhydrous tetrahydrofuran to afford a 0.55 M solution (10.0 mL), which was delivered via in syringe pump B; ^bThe conversion was determined by ¹H NMR spectroscopy using 1,1,2,2-tetrachloroethane as an internal standard; ^c Isolated yield.

A PTFE coil microflow reactor (i.d. 0.8 mm, length 200 cm, internal volume 1.0 mL) was used. Compound **12** (1.73 g, 5.0 mmol) was dissolved in anhydrous THF to afford a 0.5 M solution (10.0 mL), which was delivered via syringe pump A at a flow rate of 100 μ L/min. While tetrabutylammonium fluoride (5.5 mmol) was dissolved in anhydrous THF to afford a 0.55 M solution (10.0 mL), which was delivered via syringe pump B at the same flow rate. The two streams were mixed through a T-shaped mixer and passed through the coil reactor at 50 $^{\circ}$ C with a residence time of 5 min under 75 psi back pressure for TBS deprotection. The system was allowed to come to steady state by waiting three residence times prior to collecting product, the output flow from the reactor was collected for 60 mins. The output of the reaction mixture was quenched with saturated aqueous NH_4Cl , and extracted with EtOAc. The combined organic layers were washed with brine, dried over anhydrous Na_2SO_4 , filtered, and concentrated under reduced pressure. Purification by flash column chromatography on silica gel (petroleum ether/EtOAc = 3:1) afforded compound **13** as a colorless oil (668.5 mg, 96% yield). $[\alpha]_{\text{D}}^{25} = -76.3$ ($c = 0.59$, CHCl_3). ¹H NMR (400 MHz, CDCl_3) δ 5.37-5.33 (m, 1H), 5.18-5.15 (m, 1H), 4.67 (s, 2H), 4.60 (q, $J = 6.8$ Hz, 2H), 4.42-4.38 (m, 1H), 4.15-4.09 (m, 1H), 3.59 (dd, $J = 9.6, 5.2$ Hz, 1H), 3.46 (dd, $J = 9.6, 6.8$ Hz, 1H), 3.37 (s, 3H), 3.34 (s, 3H), 2.94-2.87 (m, 1H), 2.30-2.21 (m, 2H), 1.86-1.79 (m, 1H). ¹³C NMR (100 MHz, CDCl_3) δ 153.8, 110.8, 96.7, 95.5, 78.4, 74.2, 69.0, 55.6, 55.4, 49.6, 40.6. HRMS (ESI) m/z calcd for $\text{C}_{11}\text{H}_{20}\text{NaO}_5$ [$\text{M} + \text{Na}$]⁺: 255.1203, found: 255.1203. IR: 3435, 2932, 2888, 1146, 1104, 1026, 962, 913, 735 cm^{-1} .

Synthesis of compound **15**

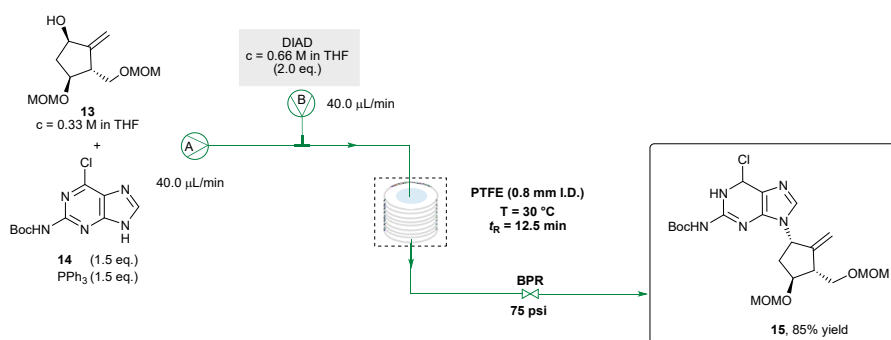

Table S6 The screening details for the synthesis of compound **15**

Entry	t _R (min)	BPR (psi)	Temp. (°C)	Conv. (%) ^b
1	2.5	0	30	18
2	5	0	30	50
3	10	0	30	56
4	12.5	0	30	60
5	15	0	30	62
6	12.5	50	30	88
7	12.5	75	30	100 (85) ^c

^aUnless otherwise specified, compound **13** (5.0 mmol), compound **14** (7.5 mmol) and triphenylphosphine (7.5 mmol) were dissolved in anhydrous tetrahydrofuran to afford a 0.33 M solution (15.0 mL), which was delivered via syringe pump A. While diisopropyl azodicarboxylate (10.0 mmol) was dissolved in anhydrous tetrahydrofuran to afford a 0.66 M solution (15.0 mL), which was delivered via syringe pump B; ^bThe conversion was determined by ¹H NMR spectroscopy using 1,1,2,2-tetrachloroethane as an internal standard; ^c Isolated yield.

A PTFE coil microflow reactor (i.d. 0.8 mm, length 200 cm, internal volume 1.0 mL) was used. Compound **13** (1.16 g, 5.0 mmol), purine **14** (2.02 g, 7.5 mmol), and PPh₃ (1.97 g, 7.5 mmol) were dissolved in anhydrous THF to afford a 0.33 M solution (15.0 mL), which was delivered via syringe pump A at a flow rate of 40 μL/min. While DIAD (2.02 g, 10.0 mmol) was dissolved in anhydrous THF to afford a 0.66 M solution (15.0 mL), which was delivered via syringe pump B at the same flow rate. The two streams were mixed through a T-shaped mixer and passed through the coil reactor at 30 °C with a residence time of 12.5 min under 75 psi back pressure. The system was allowed to come to steady state by waiting three residence times prior to collecting product, the output flow from the reactor was collected for 60 mins. The output of the reaction mixture was concentrated under reduced pressure. Purification by flash column chromatography on silica gel (petroleum ether/acetone = 9:1) afforded compound **15** as a colorless oil (368.5 mg, 85% yield). $[\alpha]_{\text{D}}^{25} = +36.0$ (c = 0.81, CHCl₃). ¹H NMR (400 MHz, CDCl₃) δ 8.10 (s, 1H), 7.52 (s, 1H), 5.64 (m, 1H), 5.33-5.30 (m, 1H), 4.94-4.90 (m, 1H), 4.73-4.61 (m, 4H), 4.35 (m, 1H), 3.88-3.80 (m, 2H), 3.39 (s, 3H), 3.37 (s, 3H), 3.02-2.86 (m, 1H), 2.53-2.45 (m, 1H), 2.44-2.36 (m, 1H), 1.54 (s, 9H). ¹³C NMR (100 MHz, CDCl₃) δ 153.0, 152.4, 151.3, 150.3, 148.6, 144.0, 128.1, 112.6, 96.8, 95.5, 81.7, 77.6, 68.6, 57.0, 55.71, 55.67, 49.9, 38.2, 28.4. HRMS (ESI) m/z calcd for C₂₁H₃₁N₅NaO₇ [M + Na]⁺: 488.2116, found: 488.2120. IR: 3264, 2925, 2852, 1750, 1570, 1511, 1149, 1031, 917, 733 cm⁻¹.

Synthesis of Entecavir (compound 5)

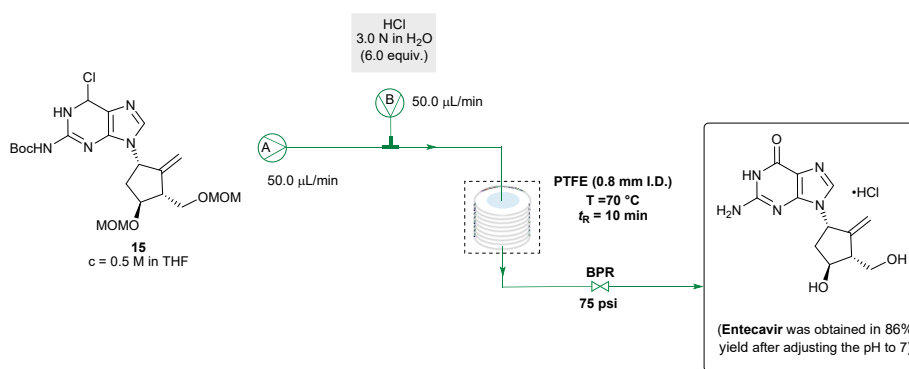

Table S7 The screening details for the synthesis of compound 5

Entry	t _R (min)	BPR (psi)	Temp. (°C)	Conv. (%)
1	2	0	60	8
2	2.5	0	60	18
3	5	0	60	42
4	10	0	60	45
5	10	50	60	72
6	10	75	60	86
7	10	100	60	89
8	10	75	70	100 (86) ^c

^aUnless otherwise specified, compound **15** (5.0 mmol) was dissolved in tetrahydrofuran to afford a 0.5 M solution (10.0 mL), which was delivered via syringe pump A. While 3 N aqueous HCl (10 mL, 30.0 mmol) was delivered via syringe pump B; ^bThe conversion was determined by ¹H NMR spectroscopy using 1,1,2,2-tetrachloroethane as an internal standard; ^c Isolated yield.

A PTFE coil microflow reactor (i.d. 0.8 mm, length 200 cm, internal volume 1.0 mL) was used. Compound **15** (2.42 g, 5.0 mmol) was dissolved in THF to afford a 0.5 M solution (10.0 mL), which was delivered via syringe pump A at a flow rate of 50 μL/min. While 3 N aqueous HCl (10 mL, 30.0 mmol) was delivered via syringe pump B at the same flow rate. The two streams were mixed through a T-shaped mixer and passed through the coil reactor at 70 °C with a residence time of 10 min under 75 psi back pressure. The system was allowed to come to steady state by waiting

three residence times prior to collecting product, the output flow from the reactor was collected for 60 mins. The output of the reaction mixture was neutralized to pH 7.0-7.5 with 2 N NaOH, and extracted with EtOAc. The solvent was removed under reduced pressure. Purification by flash column chromatography on silica gel (DCM/MeOH = 5:1) afforded Entecavir (**5**) as a white solid (357.5 mg, 86% yield). mp 249-251 °C; $[\alpha]_{\text{D}}^{25} = +35.0$ (c = 0.25, H₂O). ¹H NMR (400 MHz, DMSO-*d*₆) δ 10.55 (s, 1H), 7.65 (s, 1H), 6.39 (s, 2H), 5.41-5.31 (m, 1H), 5.10 (t, *J* = 2.4 Hz, 1H), 4.86 (d, *J* = 3.2 Hz, 1H), 4.81 (t, *J* = 5.2 Hz, 1H), 4.56 (t, *J* = 2.4 Hz, 1H), 4.25-4.21 (m, 1H), 3.59-3.49 (m, 2H), 2.54-2.50 (m, 1H), 2.27-2.16 (m, 1H), 2.09-1.99 (m, 1H). ¹³C NMR (100 MHz, DMSO-*d*₆) δ 156.8, 153.5, 151.4, 151.3, 136.0, 116.2, 109.2, 70.4, 63.0, 55.1, 54.1, 39.2. HRMS (ESI) *m/z* calcd for C₁₂H₁₅N₅NaO₃ [M + Na]⁺: 300.1067, found: 300.1070. IR: 3443, 3110, 2827, 1717, 1630, 1600, 1398, 1015 cm⁻¹.

3. The equipment of photocatalytic dehydrogenative decarboxyolefination under continuous flow



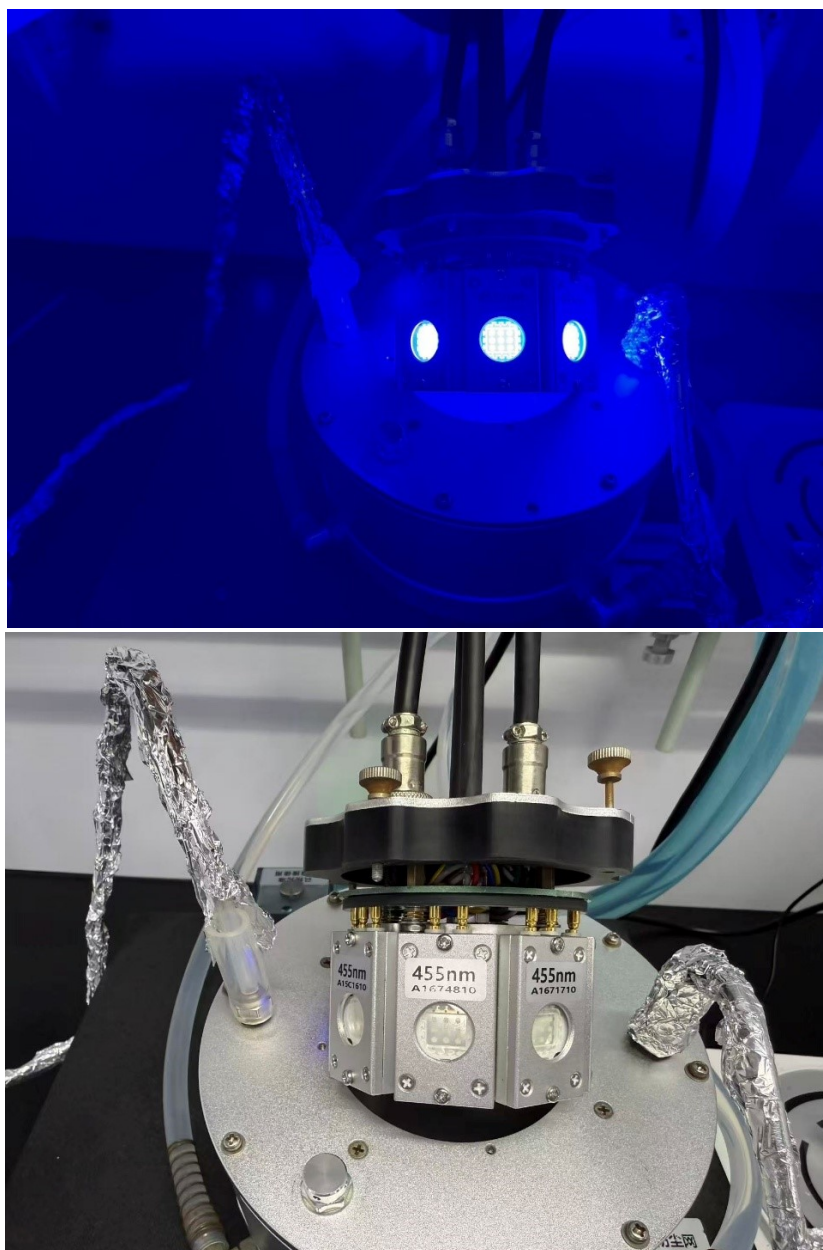

4. References

1. A. Tlahuext-Aca, L. Candish, R. A. Garza-Sanchez, F. Glorius, *ACS Catal.* 2018, **8**, 1715-1719.
2. X. Sun, J. Chen, T. Ritter, *Nature Chem.* 2018, **10**, 1229-1233.

5. NMR Spectra

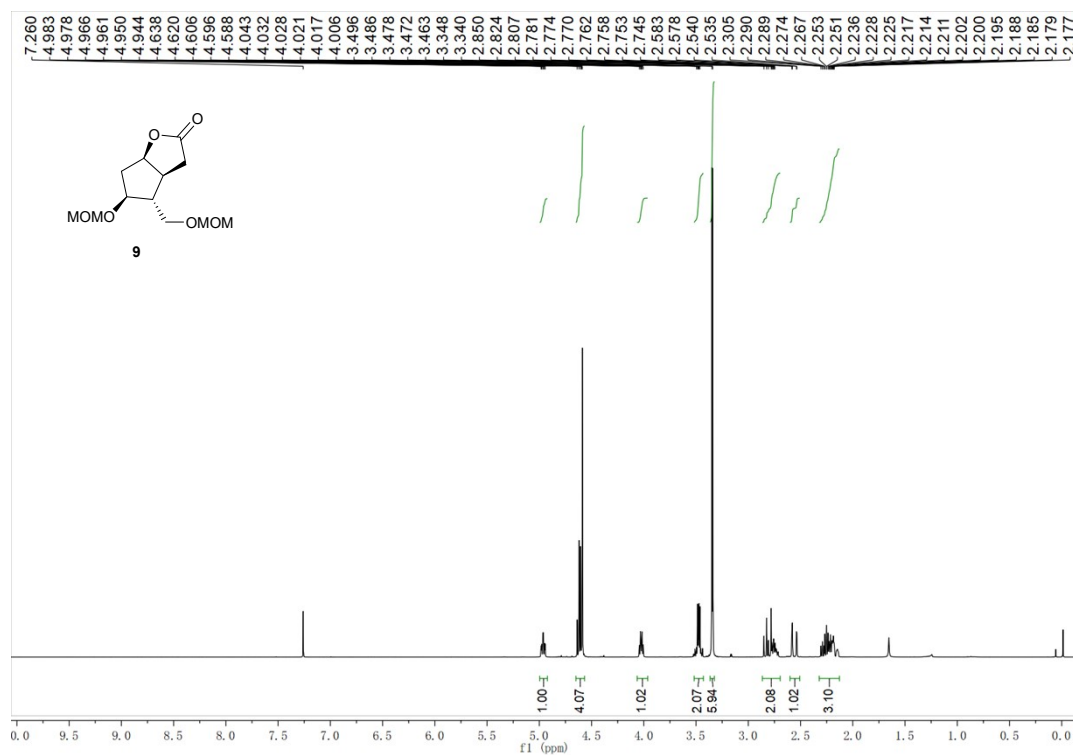

¹H NMR Spectrum (400 MHz, CDCl₃) of Compound 9

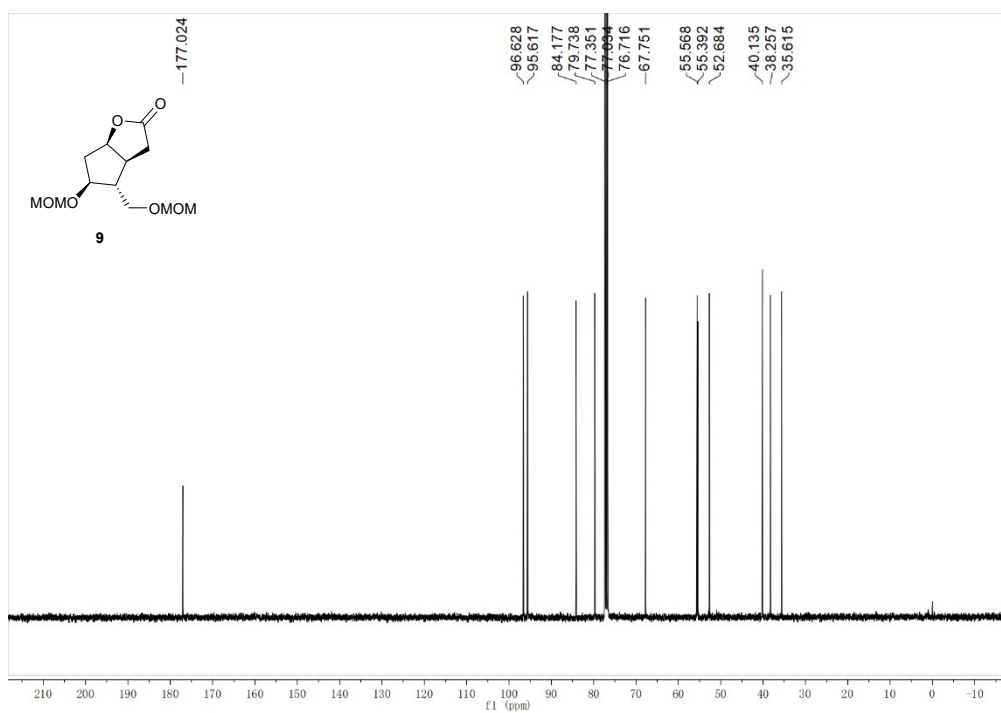

¹³C NMR Spectrum (100 MHz, CDCl₃) of Compound 9

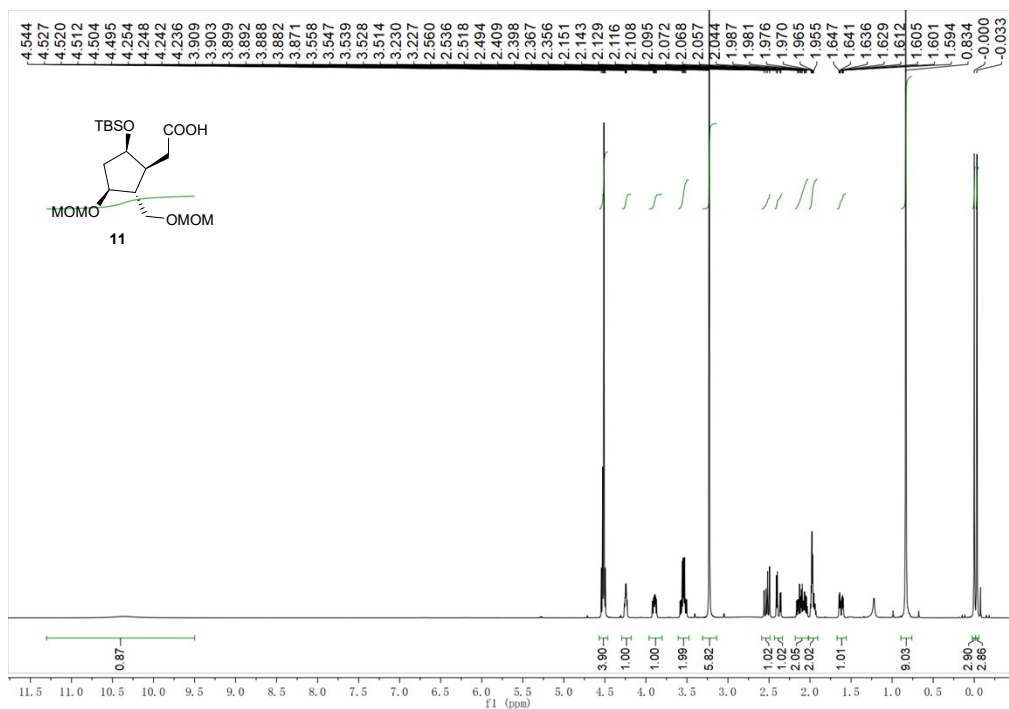

¹H NMR Spectrum (400 MHz, Acetone-*d*₆) of Compound **11**

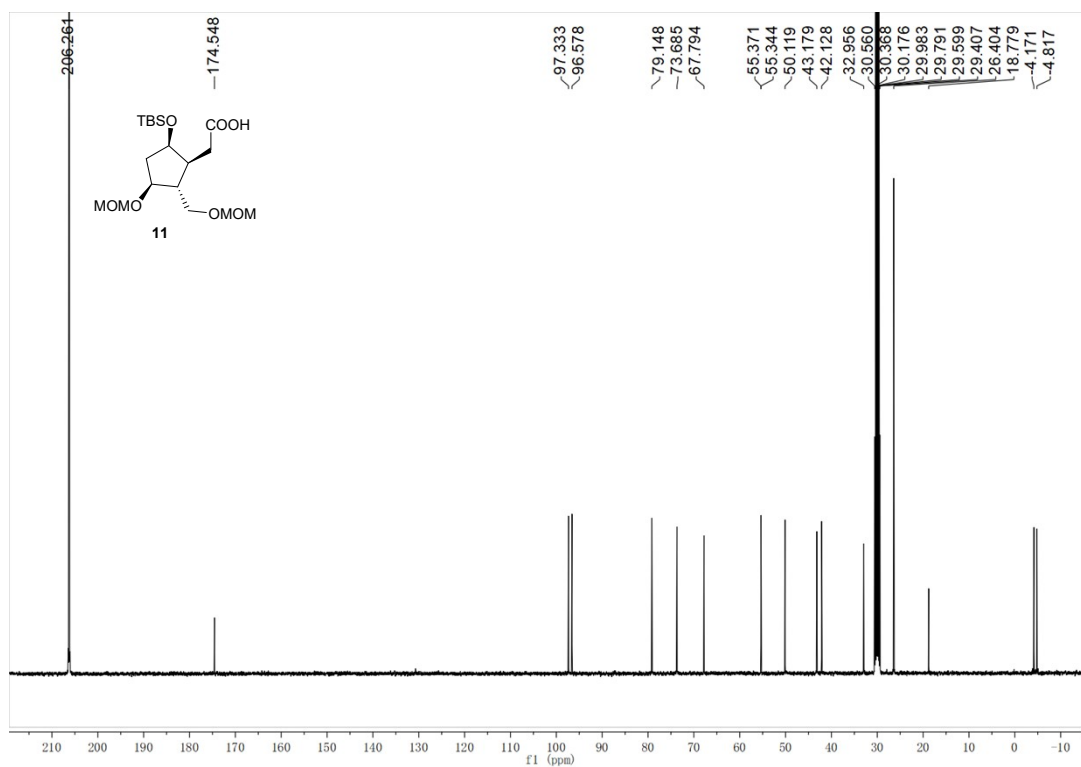

¹³C NMR Spectrum (100 MHz, Acetone-*d*₆) of **11**

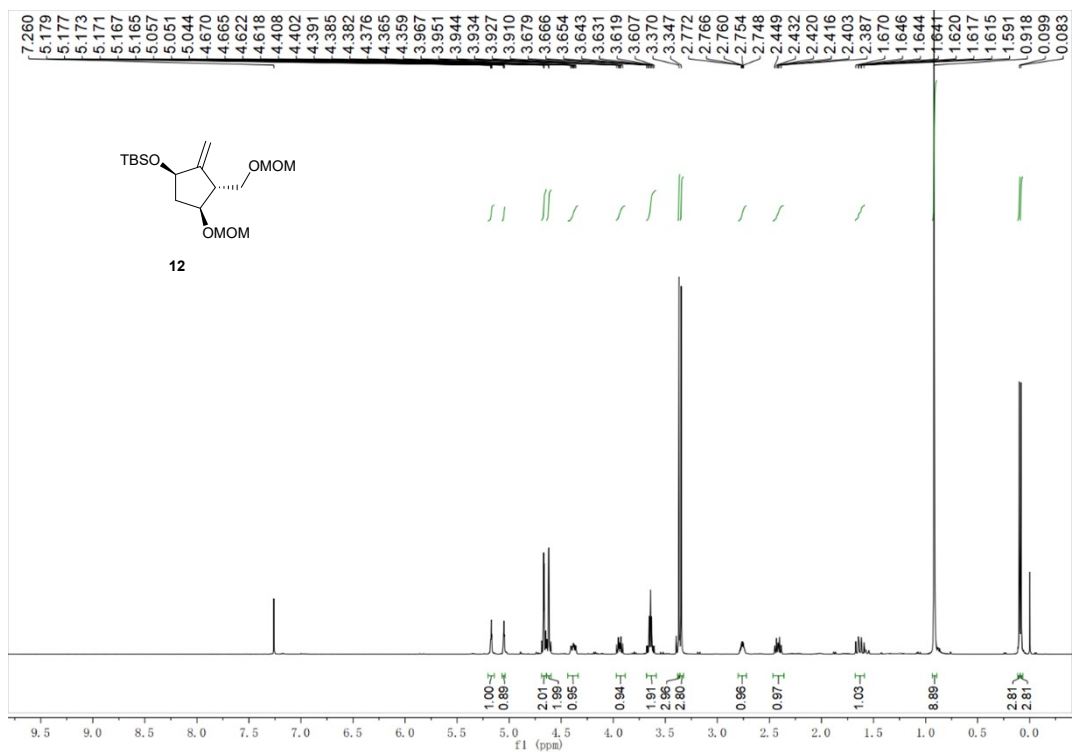

¹H NMR Spectrum (400 MHz, CDCl₃) of Compound 12

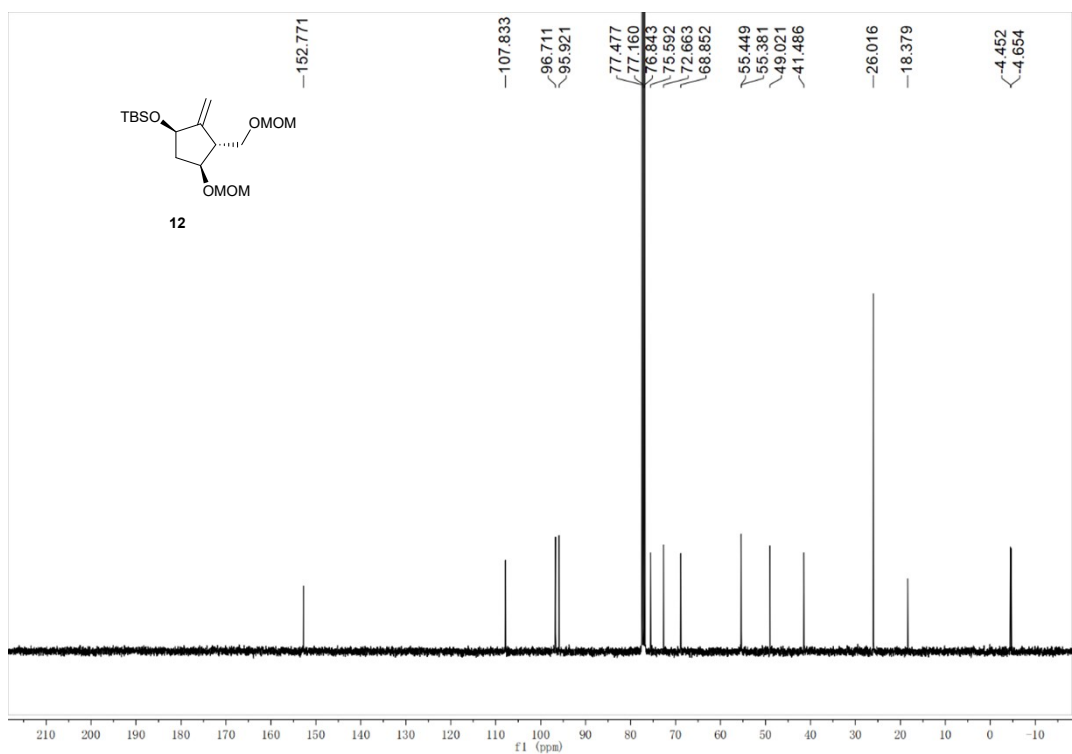

¹³C NMR Spectrum (100 MHz, CDCl₃) of Compound 12

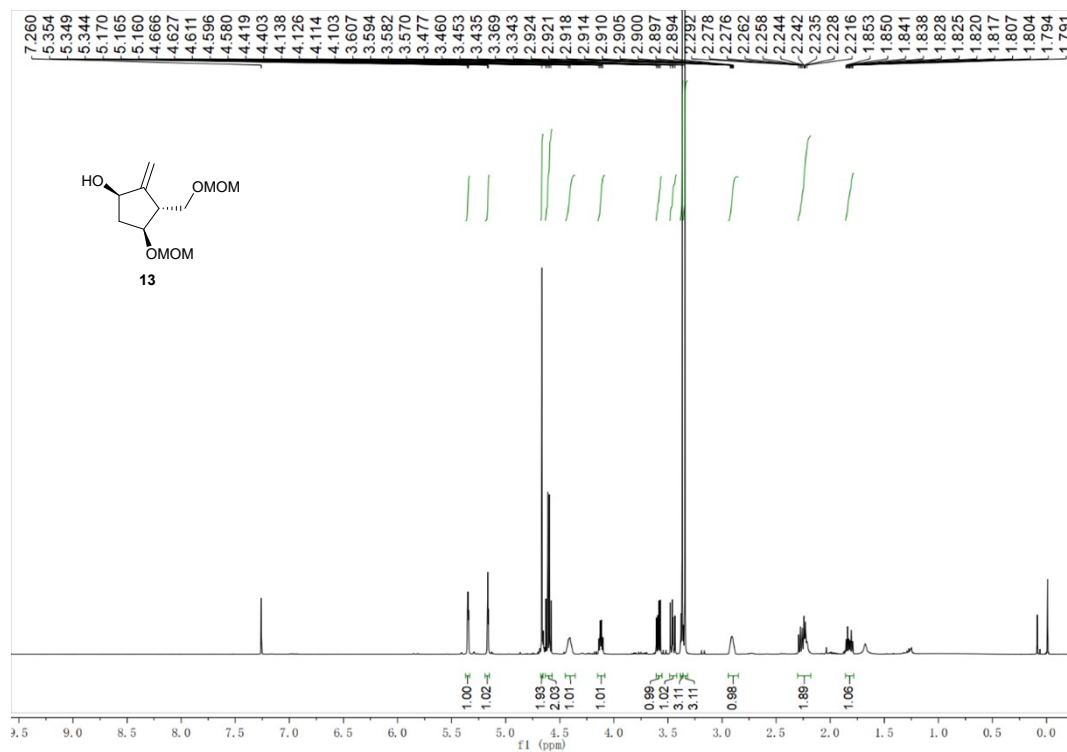

¹H NMR Spectrum (400 MHz, CDCl₃) of Compound 13

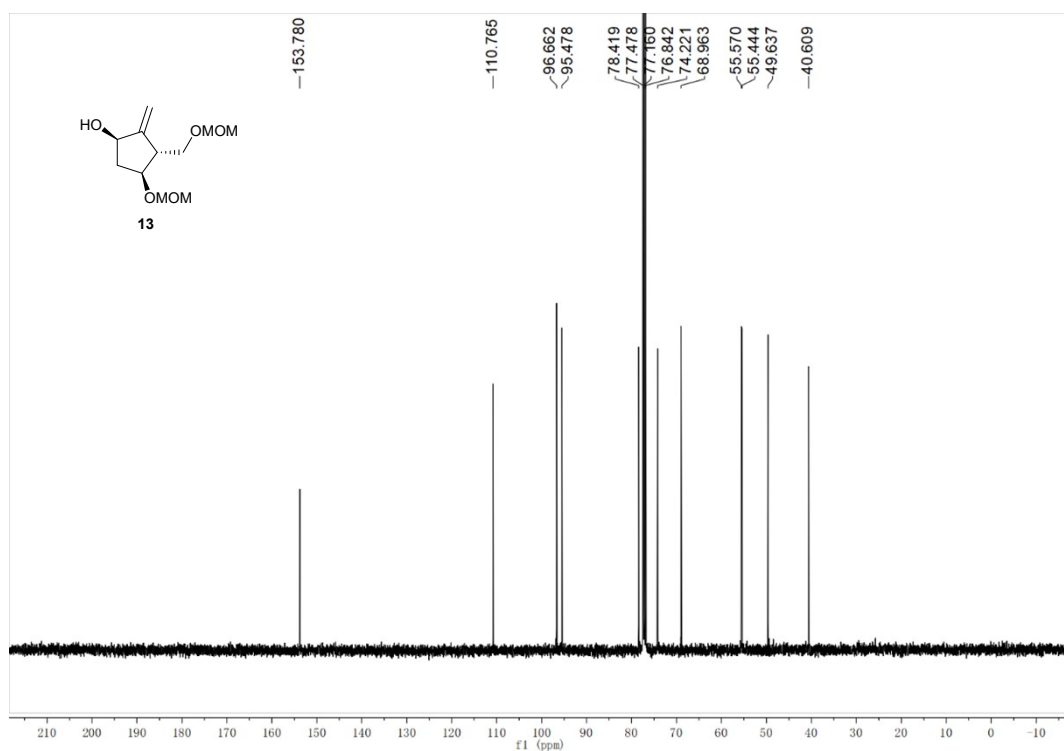

¹³C NMR Spectrum (100 MHz, CDCl₃) of Compound 13

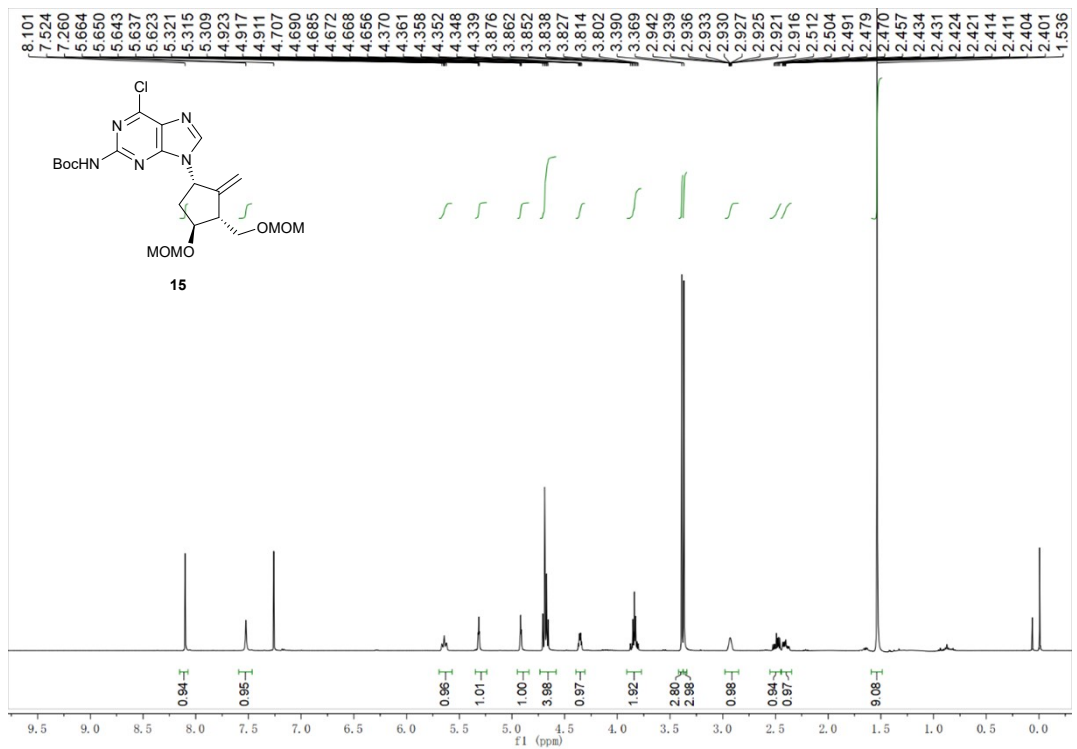

¹H NMR Spectrum (400 MHz, CDCl₃) of Compound 15

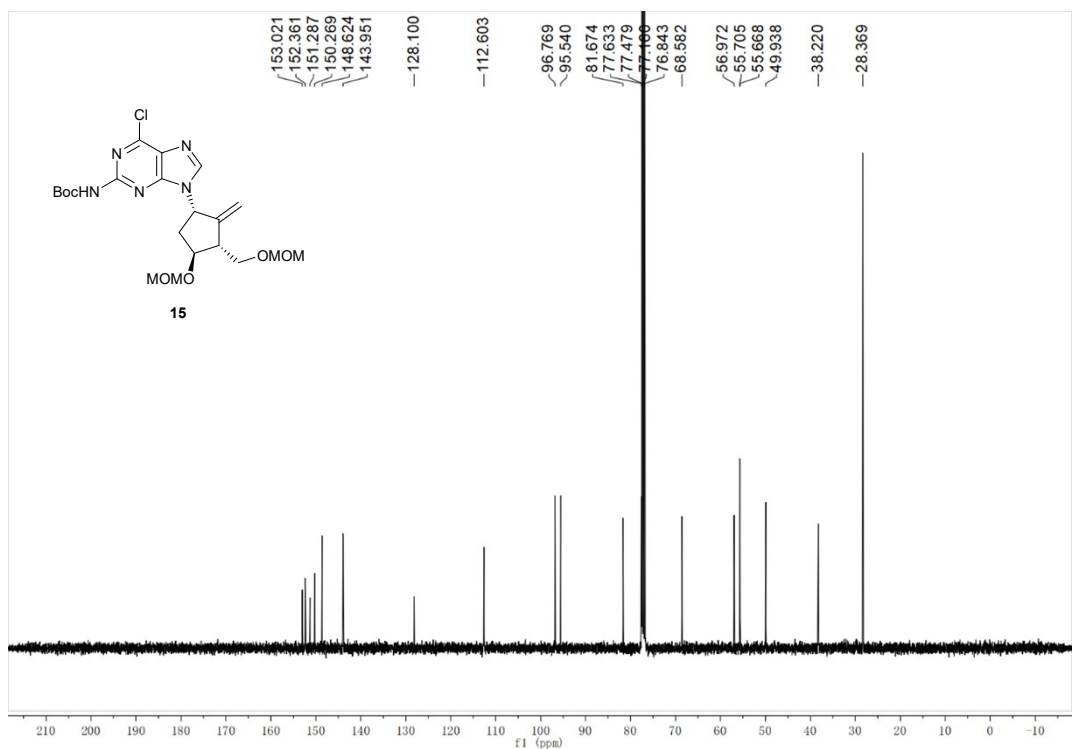

¹³C NMR Spectrum (100 MHz, CDCl₃) of Compound 15

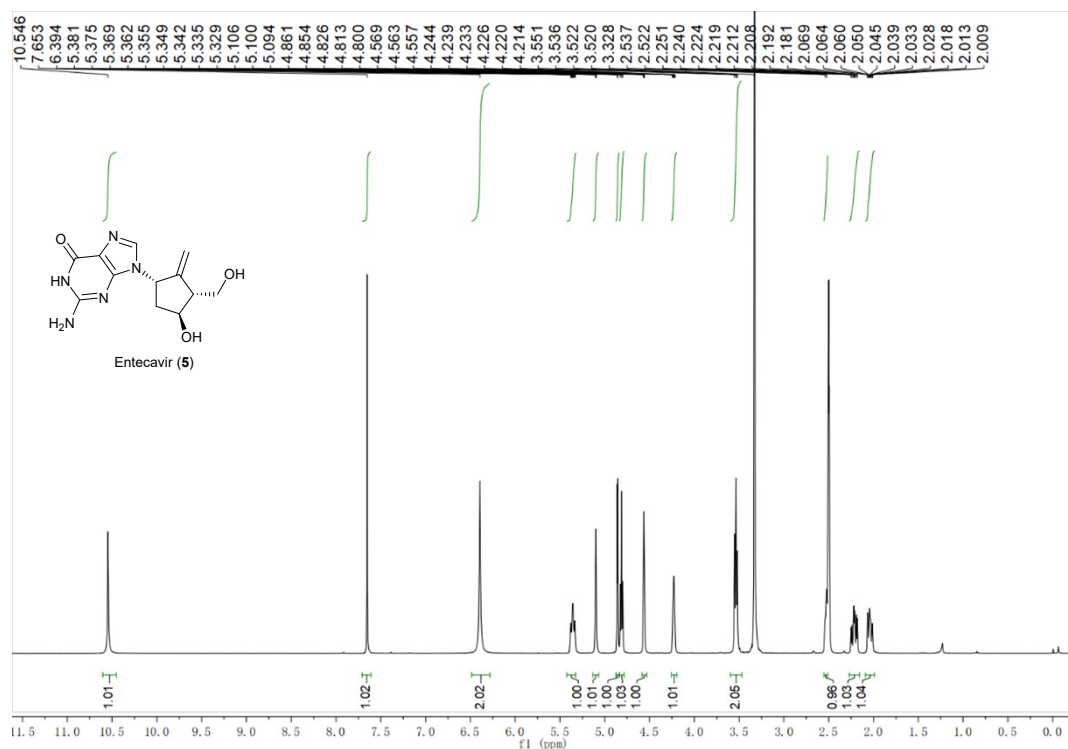

¹H NMR Spectrum (400 MHz, DMSO-d₆) of Entecavir (5)

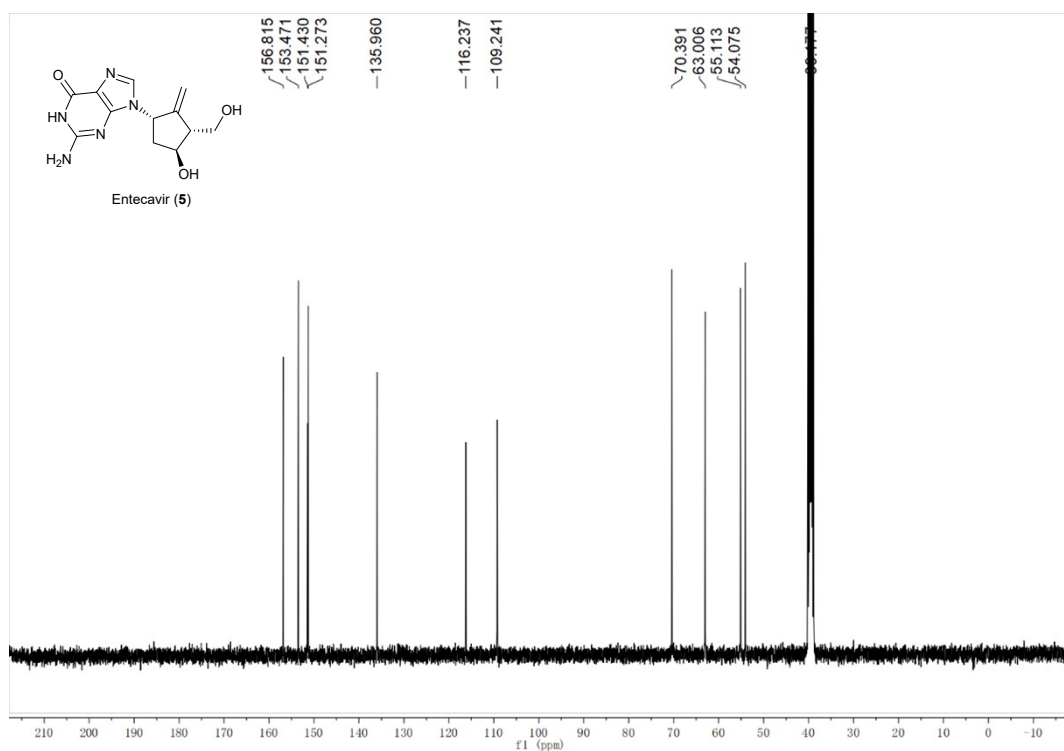

¹³C NMR Spectrum (100 MHz, DMSO-d₆) of Entecavir (5)