

Supporting Information

Electromagnetic milling-promoted steel rods-enabled Sonogashira coupling reactions of aryl halides and terminal alkynes

Xinyao Liu,^a Yanyan Chen,^a Qihong Ma,^{b,*} Meng Yu,^c Wenjie Guo,^d Baoju Wang,^a Rujun Yu,^{a,*}
Qiang Liu,^a Qing Liu^{a,*} and Hui Liu^{a,*}

a.School of Chemistry and Chemical Engineering, Shandong University of Technology Zibo,
Shandong 255049, China

b.Department of Clinical Laboratory, Zibo Central Hospital affiliated to Binzhou Medical University,
Shandong 255049, China

c.Zibo Construction Project Environmental Review Service Center, Shandong 255049, China

d.Shandong Diam Chemical Co., Ltd, Shandong 256800, China

Table of contents

1. General information	1
2. General procedure for the EMM-driven steel rods-enabled Sonogashira coupling reactions	3
3. Ferromagnetic rods of different specifications	4
4. Control of magnetic field intensity	5
5. Analytical data of substrates	6
6. References	11
7. Copies of the ^1H NMR and ^{13}C NMR spectra	12

1. General information

All starting materials and solvents were used as received from commercial sources without further purification. The ferromagnetic rod used is SUS304 stainless steel, which is purchased from Dongguan Feiada Metal Materials Co., Ltd. and then processed by ourselves. Solvents were purchased from commercial suppliers. Purifications of reactions products were carried out by flash chromatography using Merck silica gel (40-63 μm). All mechanochemical reactions were carried out using grinding vessels in a magnetic grinding machine. The reaction bottles used were customized custom-made vial (2.6 * 4.0 cm). The grinding medium is customized ferromagnetic rods (0.3 * 5.0 mm). ^1H NMR (400 MHz), ^{13}C NMR (101 MHz) and ^{19}F NMR (377MHz) were measured on a Bruker Avance 400 MHz spectrometer. Chemical shifts are reported in parts per million (ppm, δ) downfield from residual solvents peaks and coupling constants are reported as Hertz (Hz). Splitting patterns are designated as singlet (s), doublet (d), triplet (t).....Splitting patterns that could not be interpreted or easily visualized are designated as multiple (m).

About the magnetic grinding used: the magnetic grinding machine (Figure S1) is self-developed and has not yet been put into commercial use, and the instrument consists of two parts, the working room (left blue part of the picture) and the console (right part of the picture). The left cavity is the main working part. The four square magnets rotate around the cavity to form a rotating magnetic field, which drives the ferromagnetic rod to move. The Gaussmeter measurements showed that the magnetic intensity gradually decreased as the distance from the magnets increased, ranging from 0.24 T near the magnets to 0.05 T further away



Figure S1. Magnetic Ginding equipment

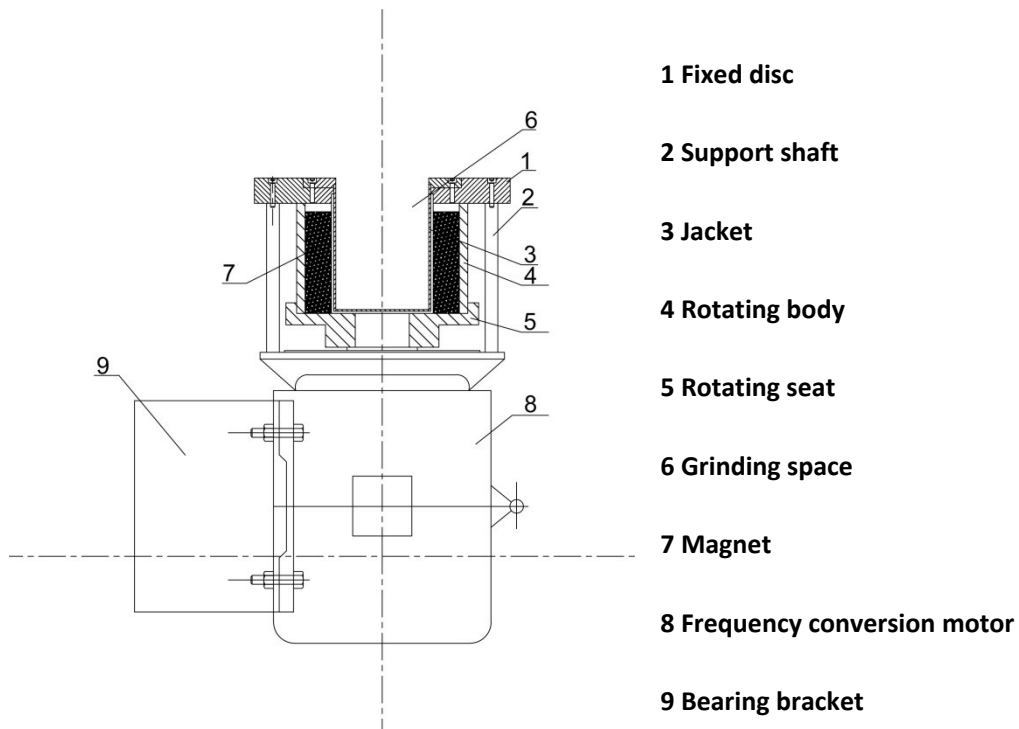

Figure S2. Plan view of Magnetic Ginding equipment (left blue part)

2. General procedure for the EMM-driven steel rods-enabled Sonogashira coupling reactions

P-terbutyl iodobenzene **1a** (0.1561 g, 0.6 mmol, 2.0 equiv.), phenylacetylene **2a** (0.0306 g, 0.3 mmol, 1.0 equiv.), DABCO (0.0508 g, 0.45 mmol, 1.5 equiv.), dtbbpy (0.0089 g, 10 mol%) and K_3PO_4 (0.1274 g, 0.6 mmol, 2.0 equiv.) were charged into a reaction tube, then the steel rods were introduced. The sealed reaction tube was then placed in rotating magnetic field ($B = 0.28$ T, $V = 50$ Hz) for 3 h. Upon completion, the steel needle was removed, and the reaction mixture was extracted with ethyl acetate. The combined organic layers were concentrated under reduced pressure and purified by flash column chromatography [petroleum ether (PE)] to afford compound **3a**.

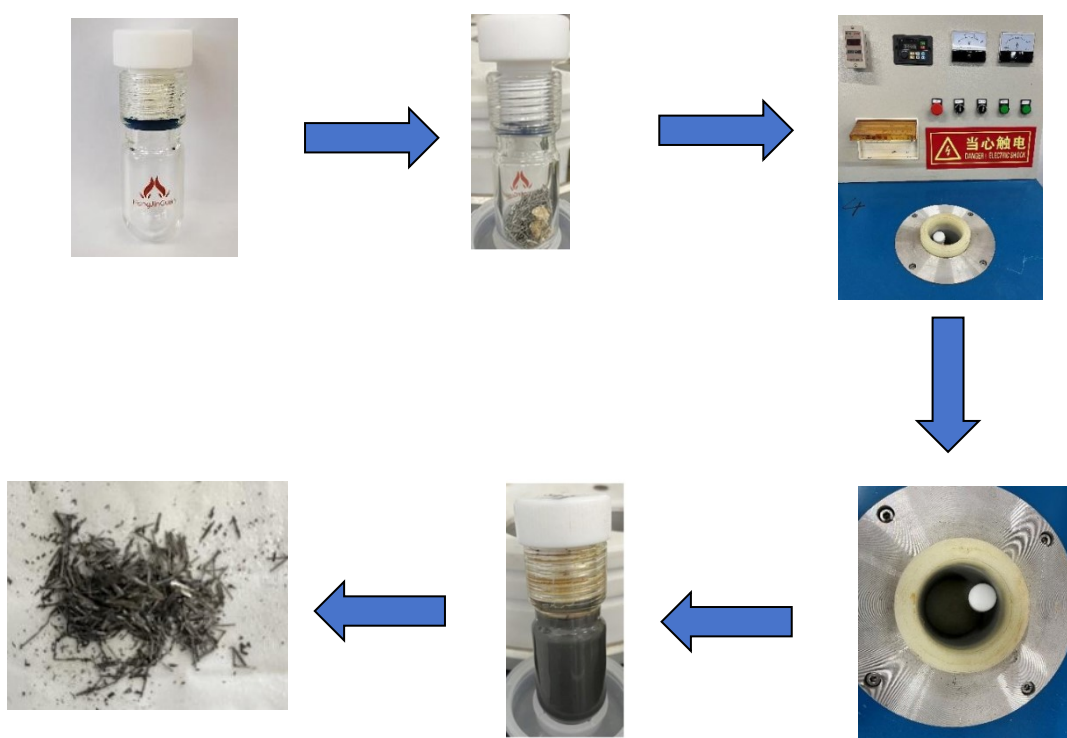

Figure S3. Set-up procedure for Aryl halides and Terminal alkynes: Rotating Magnetic Field Driven, Steel Rods-enabled Sonogashira Coupling Reactions.

3. Ferromagnetic rods of different specifications



0.2*10 mm



0.5*10 mm

1.0*10 mm



0.3*5 mm



1.0*30 mm

Figure. S4. Ferromagnetic rods of different sizes used in experiments.

4. Control of magnetic field intensity

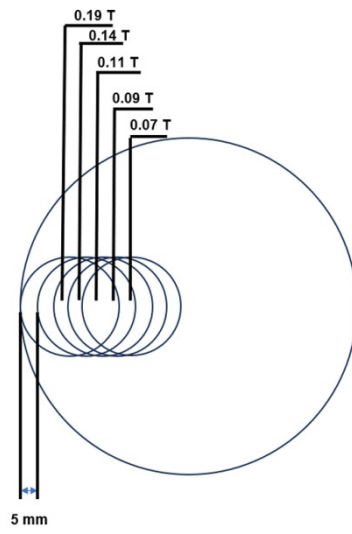
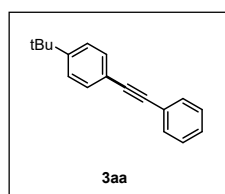

Figure. S5. Control of magnetic field intensity.

5. Analytical data of substrates



1-(tert-butyl)-4-(phenylethynyl)benzene¹

C₁₈H₁₈

MW: 234.34 g*mol⁻¹

White solid

Yield: 88%

61.83 mg

¹H NMR (400 MHz, CDCl₃, δ ppm): 7.55 (dd, J = 7.3, 2.3 Hz, 2H), 7.50 (d, J = 8.6 Hz, 2H), 7.41 – 7.34 (m, 5H), 1.35 (s, 9H).

¹³C NMR (101 MHz, CDCl₃, δ ppm): 151.6, 131.7, 131.5, 128.6, 128.4, 128.2, 125.5, 123.6, 120.4, 89.7, 88.9, 34.9, 31.3

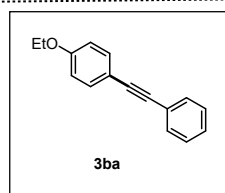

1-ethoxy-4-(phenylethynyl)benzene²

C₁₆H₁₄O

MW: 222.29 g*mol⁻¹

White solid

Yield: 48%

32.01 mg

¹H NMR (400 MHz, CDCl₃, δ ppm): 7.56 – 7.42 (m, 4H), 7.40 – 7.29 (m, 3H), 6.87 (d, J = 8.7 Hz, 2H), 4.05 (q, J = 7.0 Hz, 2H), 1.43 (t, J = 7.0 Hz, 3H).

¹³C NMR (101 MHz, CDCl₃, δ ppm): 159.1, 133.2, 131.6, 128.4, 128.0, 123.7, 115.3, 114.6, 89.6, 88.1, 63.6, 14.9.

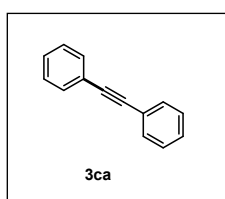

1,2-diphenylethyne³

C₁₄H₁₀

MW: 178.23 g*mol⁻¹

White solid

Yield: 60%

32.08 mg

¹H NMR (400 MHz, CDCl₃, δ ppm): 7.60 – 7.54 (m, 4H), 7.41 – 7.33 (m, 6H).

¹³C NMR (101 MHz, CDCl₃, δ ppm): 131.7, 128.5, 128.4, 123.4, 89.5.

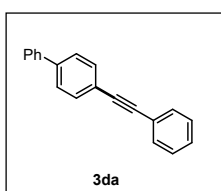

4-(phenylethynyl)-1,1'-biphenyl¹

C₂₀H₁₄

MW: 254.33 g*mol⁻¹

White solid

Yield: 61%

46.54 mg

¹H NMR (400 MHz, CDCl₃, δ ppm): 7.63 (dd, J = 8.7, 1.7 Hz, 6H), 7.59 – 7.55 (m, 2H), 7.47–7.41 (m, 2H), 7.41 – 7.34 (m, 4H).

¹³C NMR (101 MHz, CDCl₃, δ ppm): 141.1, 140.5, 132.2, 131.8, 129.0, 128.5, 128.4, 127.8, 127.2, 123.4, 122.3, 90.2, 89.4.

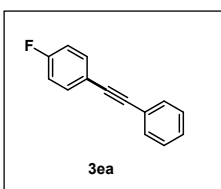

1-fluoro-4-(phenylethynyl)benzene¹

C₁₄H₉F

MW: 196.22 g*mol⁻¹

White solid

Yield: 64%

37.67 mg

¹H NMR (400 MHz, CDCl₃, δ ppm): 7.26–7.21 (m, 4H), 7.08–7.04 (m, 3H), 6.77–6.73 (m, 2H).

¹³C NMR (101 MHz, CDCl₃, δ ppm): 163.84, 161.36, 133.64, 133.55, 131.67, 128.50, 128.46, 123.19, 119.48, 119.45, 115.87, 115.65, 89.18, 89.16, 88.42.

¹⁹F NMR (377 MHz, CDCl₃, δ ppm): -110.84 (m, 1F).

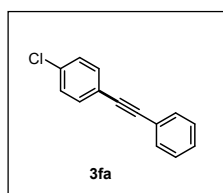
**1-chloro-4-(phenylethynyl)benzene⁴**C₁₄H₉Cl

White solid

26.16 mg

MW: 212.68 g*⁻¹mol⁻¹

Yield: 41%

¹H NMR (400 MHz, CDCl₃, δ ppm): 7.57 – 7.51 (m, 2H), 7.47 (d, *J* = 8.1 Hz, 2H), 7.40 – 7.30 (m, 5H).

¹³C NMR (101 MHz, CDCl₃, δ ppm): 134.4, 132.9, 131.7, 128.8, 128.6, 128.5, 123.0, 121.9, 90.4, 88.4.

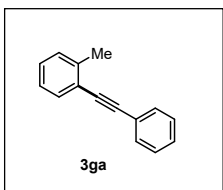
**1-methyl-2-(phenylethynyl)benzene³**C₁₅H₁₂

White solid

31.73 mg

MW: 192.26 g*⁻¹mol⁻¹

Yield: 55%

¹H NMR (400 MHz, CDCl₃, δ ppm): 7.49 – 7.41 (m, 3H), 7.28 – 7.23 (m, 3H), 7.15 (d, *J* = 3.7 Hz, 2H), 7.12 – 7.06 (m, 1H), 2.44 (s, 3H).

¹³C NMR (101 MHz, CDCl₃, δ ppm): 140.3, 131.9, 131.6, 129.6, 128.5, 128.4, 128.3, 125.7, 123.7, 123.1, 93.5, 88.5, 20.9.

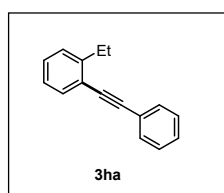
**1-ethyl-2-(phenylethynyl)benzene²**C₁₆H₁₄

Yellow liquid

34.04 mg

MW: 206.29 g*⁻¹mol⁻¹

Yield: 55%

¹H NMR (400 MHz, CDCl₃, δ ppm): 7.57 – 7.48 (m, 3H), 7.39 – 7.30 (m, 3H), 7.30 – 7.22 (m, 2H), 7.18 (m, 1H), 2.90 (q, *J* = 7.6 Hz, 2H), 1.31 (t, *J* = 7.6 Hz, 3H).

¹³C NMR (101 MHz, CDCl₃, δ ppm): 146.4, 132.3, 131.6, 128.7, 128.5, 128.3, 128.1, 125.8, 123.7, 122.4, 93.0, 88.3, 28.0, 15.0.

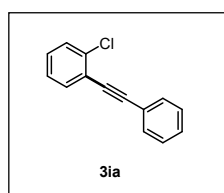
**1-chloro-2-(phenylethynyl)benzene²**C₁₄H₉Cl

White solid

29.99 mg

MW: 212.68 g*⁻¹mol⁻¹

Yield: 47%

¹H NMR (400 MHz, CDCl₃, δ ppm): 7.65–7.59 (m, 1H), 7.58–7.52 (m, 2H), 7.47 – 7.42 (m, 1H), 7.37 (dd, *J* = 4.9, 1.9 Hz, 3H), 7.26 (s, 2H).

¹³C NMR (101 MHz, CDCl₃, δ ppm): 136.1, 133.4, 131.9, 129.4, 129.4, 128.8, 128.5, 126.6, 123.3, 123.0, 94.7, 86.3.

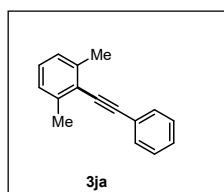
**1,3-dimethyl-2-(phenylethynyl)benzene²**C₁₆H₁₄

Yellow liquid

38.99 mg

MW: 206.29 g*⁻¹mol⁻¹

Yield: 63%

¹H NMR (400 MHz, CDCl₃, δ ppm): 7.57 (dd, *J* = 7.8, 1.8 Hz, 2H), 7.37 (d, *J* = 7.8 Hz, 3H), 7.18 – 7.07 (m, 3H), 2.54 (s, 6H).

¹³C NMR (101 MHz, CDCl₃, δ ppm): 140.4, 131.5, 128.5, 128.2, 127.9, 126.8, 123.9, 123.1, 98.0, 87.2, 21.3.

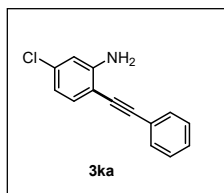
**5-chloro-2-(phenylethynyl)aniline⁵** $C_{14}H_{10}ClN$

White solid

36.89 mg

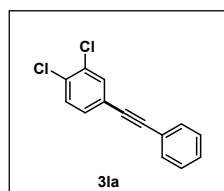
MW: 227.69 g^{*}mol⁻¹**Yield:** 54%**¹H NMR (400 MHz, CDCl₃, δ ppm):** 7.42 (d, *J* = 4.7 Hz, 2H), 7.38–7.32 (m, 3H), 7.18 (d, *J* = 8.2 Hz, 1H), 6.66 – 6.52 (m, 2H), 4.25 (s, 2H).**¹³C NMR (101 MHz, CDCl₃, δ ppm):** 148.8, 135.4, 133.2, 131.6, 128.6, 123.1, 118.3, 114.2, 106.6, 95.5, 85.0.**1,2-dichloro-4-(phenylethynyl)benzene⁵** $C_{14}H_8Cl_2$

White solid

26,29 mg

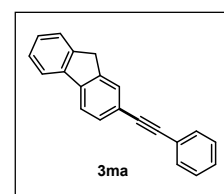
MW: 247.12 g^{*}mol⁻¹**Yield:** 36%**¹H NMR (400 MHz, CDCl₃, δ ppm):** 7.63 (d, *J* = 1.9 Hz, 1H), 7.54 (dd, *J* = 6.5, 3.1 Hz, 2H), 7.42 (d, *J* = 8.3 Hz, 1H), 7.39 – 7.33 (m, 4H).**¹³C NMR (101 MHz, CDCl₃, δ ppm):** 133.3, 132.7, 132.7, 131.8, 130.8, 130.5, 128.9, 128.6, 123.4, 122.6, 91.4, 87.2.**2-(phenylethynyl)-9H-fluorene⁶** $C_{21}H_{14}$

White solid

37.36 mg

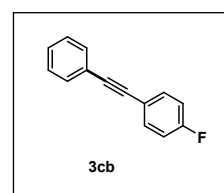
MW: 266.34g^{*}mol⁻¹**Yield:** 41%**¹H NMR (400 MHz, CDCl₃, δ ppm):** 7.66 (m, 3H), 7.45 (m, 4H), 7.30–7.24 (m, 5H), 3.81 (s, 2H).**¹³C NMR (101 MHz, CDCl₃, δ ppm):** 143.7, 143.3, 142.0, 141.2, 131.7, 130.6, 128.5, 128.0, 128.3, 127.3, 127.1, 125.2, 123.6, 121.4, 120.3, 119.9, 90.3, 89.5, 36.9.**1-fluoro-4-(phenylethynyl)benzene¹** $C_{14}H_9F$

White solid

26.49 mg

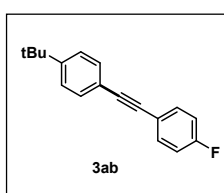
MW: 196.22 g^{*}mol⁻¹**Yield:** 45%**¹H NMR (400 MHz, CDCl₃, δ ppm):** 7.28–7.22 (m, 4H), 7.10–7.04 (m, 3H), 6.79–6.73 (m, 2H).**¹³C NMR (101 MHz, CDCl₃, δ ppm):** 163.8, 161.4 133.6 133.6, 131.7, 128.5, 128.5, 123.2, 119.5, 119.5, 115.9, 115.7, 89.2, 89.2, 88.4.**¹⁹F NMR (377 MHz, CDCl₃, δ ppm):** -110.84 (m, 1F).**1-(tert-butyl)-4-((4-fluorophenyl)ethynyl)benzene⁷** $C_{18}H_{17}F$

White solid

40.88 mg

MW: 252.33 g^{*}mol⁻¹**Yield:** 54%**¹H NMR (400 MHz, CDCl₃, δ ppm):** 7.50 (dd, *J* = 8.7, 5.6 Hz, 2H), 7.46 (d, *J* = 8.5 Hz, 2H), 7.37 (d, *J* = 8.5 Hz, 2H), 7.04 (m, 2H), 1.33 (s, 9H).**¹³C NMR (101 MHz, CDCl₃, δ ppm):** 163.8, 161.3, 151.8, 133.6, 133.5, 131.4, 125.5, 120.2 119.7,

119.7 115.8, 115.6, 89.3, 89.3, 87.8, 35.0, 31.3.

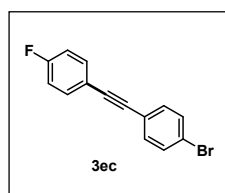

1-bromo-4-((4-fluorophenyl)ethynyl)benzene⁸

C₁₄H₈BrF

MW: 226.25 g*mol⁻¹

White solid

Yield: 44%

29.87 mg

¹H NMR (400 MHz, CDCl₃, δ ppm): 7.54 – 7.45 (m, 4H), 7.38 (d, *J* = 8.4 Hz, 2H), 7.05 (td, *J* = 8.7, 5.4 Hz, 2H)..

¹³C NMR (101 MHz, CDCl₃, δ ppm): 163.99, 161.50, 133.67, 133.59, 133.09, 131.78, 122.70, 122.17, 119.14, 119.11, 115.98, 115.76, 89.54, 88.13, 88.11.

¹⁹F NMR (377 MHz, CDCl₃, δ ppm): -110.41 (ddd, *J* = 13.8, 8.6, 5.3 Hz, 1F).

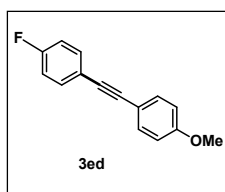

1-fluoro-4-((4-methoxyphenyl)ethynyl)benzene⁹

C₁₅H₁₁FO

MW: 226.25 g*mol⁻¹

White solid

Yield: 36%

24.44 mg

¹H NMR (400 MHz, CDCl₃, δ ppm): 7.49 (t, *J* = 10.3 Hz, 4H), 7.04 (t, *J* = 8.5 Hz, 2H), 6.89 (d, *J* = 8.3 Hz, 2H), 3.83 (s, 3H).

¹³C NMR (101 MHz, CDCl₃, δ ppm): 163.6, 161.2, 159.8, 133.4, 133.4, 133.1, 119.8, 119.8 115.8, 115.6, 115.3, 114.1, 89.2, 89.1, 87.1, 55.4.

¹⁹F NMR (377 MHz, CDCl₃, δ ppm): -111.45 (m, 1F).

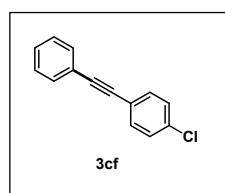

1-chloro-4-(phenylethynyl)benzene⁴

C₁₄H₉Cl

MW: 212.68 g*mol⁻¹

White solid

Yield: 51%

32.55 mg

¹H NMR (400 MHz, CDCl₃, δ ppm): 7.57 – 7.51 (m, 2H), 7.47 (d, *J* = 8.1 Hz, 2H), 7.40 – 7.30 (m, 5H).

¹³C NMR (101 MHz, CDCl₃, δ ppm): 136.1, 133.4, 131.9, 129.4, 129.4, 128.8, 128.5 126.6, 123.3, 123.0, 94.7, 86.3.

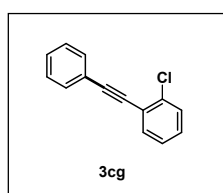

1-chloro-2-(phenylethynyl)benzene²

C₁₄H₉Cl

MW: 212.68 g*mol⁻¹

White solid

Yield: 48%

29.99 mg

¹H NMR (400 MHz, CDCl₃, δ ppm): 7.58 (m, 3H), 7.47 – 7.42 (m, 1H), 7.37 (dd, *J* = 4.9, 1.9 Hz, 3H), 7.30–7.24 (m, 2H).

¹³C NMR (101 MHz, CDCl₃, δ ppm): 136.1, 133.4 131.9, 129.4, 129.4, 128.8, 128.5, 126.6, 123.3, 123.0, 94.7, 86.3.

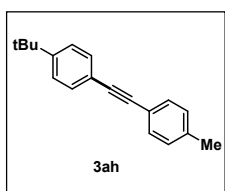

1-(tert-butyl)-4-(p-tolyethynyl)benzene⁷

C₁₉H₂₀

MW: 248.37 g*mol⁻¹

White solid

Yield: 56%

41.73 mg

¹H NMR (400 MHz, CDCl₃, δ ppm): 7.44 (dd, *J* = 15.1, 7.8 Hz, 4H), 7.36 (d, *J* = 8.0 Hz, 2H), 7.15 (d, *J* = 7.7 Hz, 2H), 2.36 (s, 3H), 1.32 (s, 9H).

¹³C NMR (101 MHz, CDCl₃, δ ppm): 151.5, 138.3, 131.6, 131.4, 129.2, 125.5, 120.6, 120.5, 89.0, 89.0, 35.0, 31.3, 21.7.

6. References.

- 1 Q. Chen, L. Fu and Y. Nishihara, *Chem. Commun.*, 2020, **56**, 11735–11738.
- 2 D. Domyati, R. Latifi and L. Tahsini, *J. Organomet. Chem.*, 2018, **860**, 98–105.
- 3 J. Li, Y. Liang and Y. Xie, *J. Org. Chem.*, 2005, **70**, 4393–4396.
- 4 D. A. Fulmer, W. C. Shearouse, S. T. Medonza and J. Mack, *Green Chem.*, 2009, **11**, 1821–1825.
- 5 W. A. Golding, R. Pearce-Higgins and R. J. Phipps, *J. Am. Chem. Soc.*, 2018, **140**, 13570–13574.
- 6 C. D. Hurd and F. L. Cohen, *J. Am. Chem. Soc.*, 1931, **53**, 1073.
- 7 Y. Yang, J. F. Y. Lim, X. Chew, E. G. Robins, C. W. Johannes, Y. H. Lim and H. Jong, *Catal. Sci. Technol.*, 2015, **5**, 4365–4377.
- 8 Y. Qu and Y. Li, *J. Mol. Struct.*, 2025, **1330**, 141466.
- 9 X. Zhang, Q. Liu, J. Gao, L. Zhang, F. Yan, S. Zhuo and H. Liu, *Adv. Synth. Catal.*, 2025, **367**, e202500100.

7. Copies of the ^1H NMR and ^{13}C NMR spectra

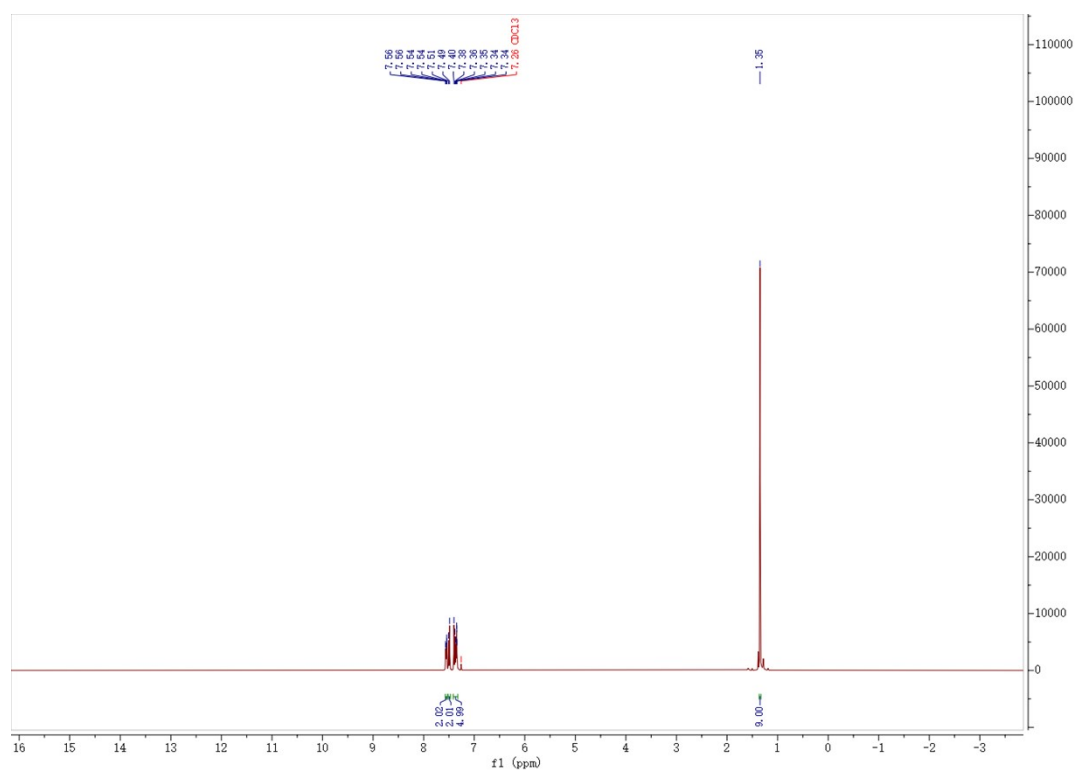

^1H NMR (400 MHz, CDCl_3) of product **3aa**

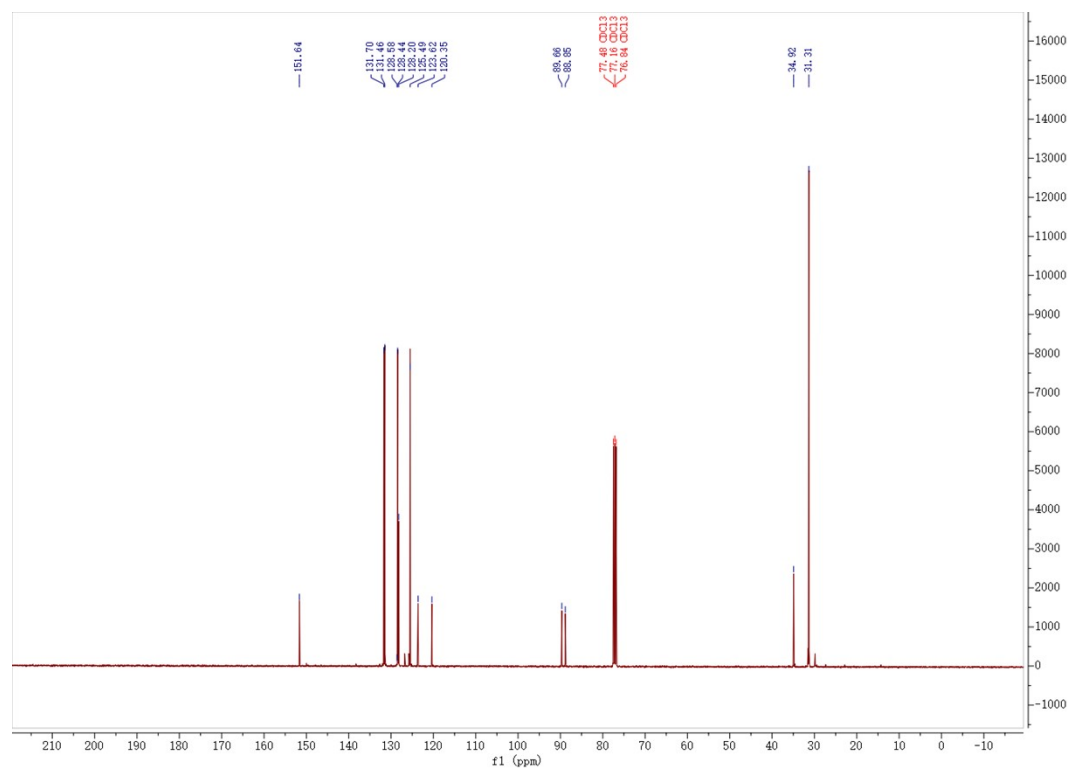

^{13}C NMR (101 MHz, CDCl_3) of product **3aa**

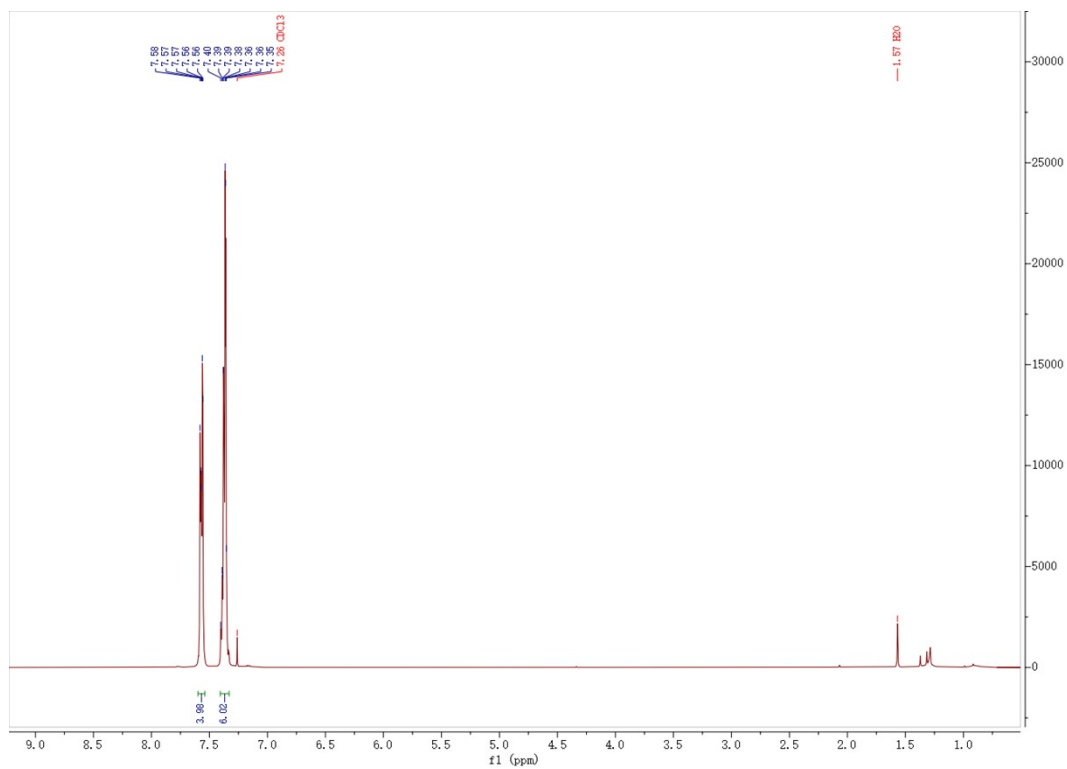

¹H NMR (400 MHz, CDCl₃) of product **3ca**

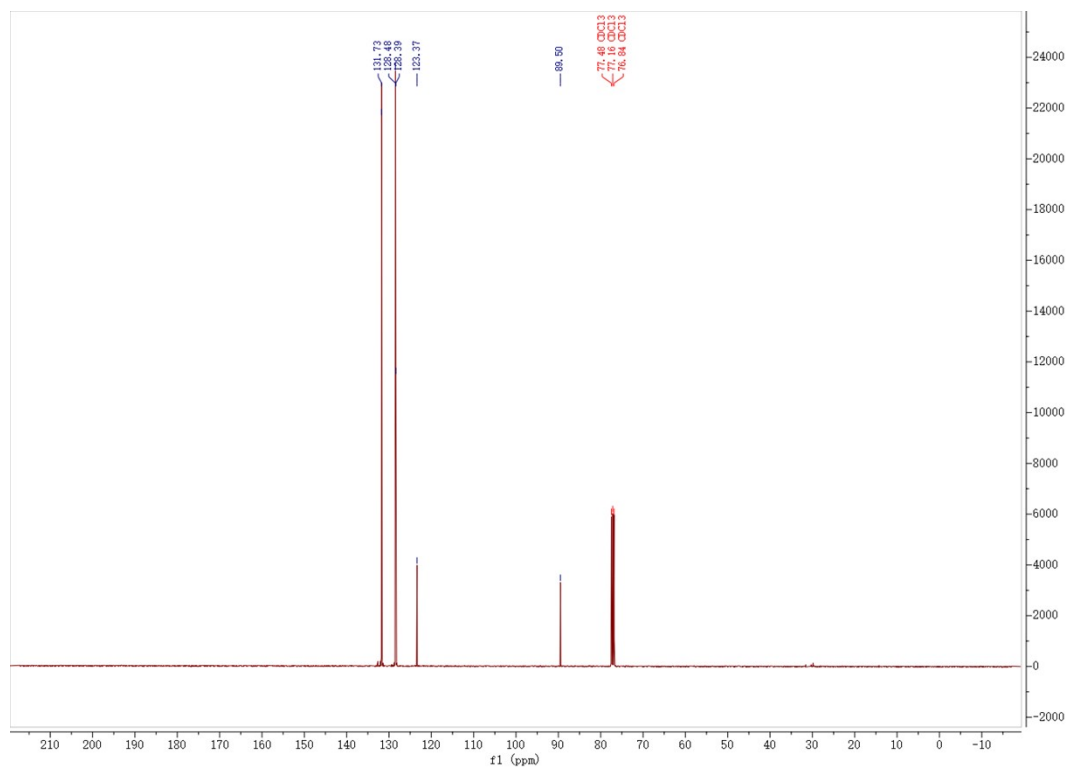

¹³C NMR (101 MHz, CDCl₃) of product **3ca**

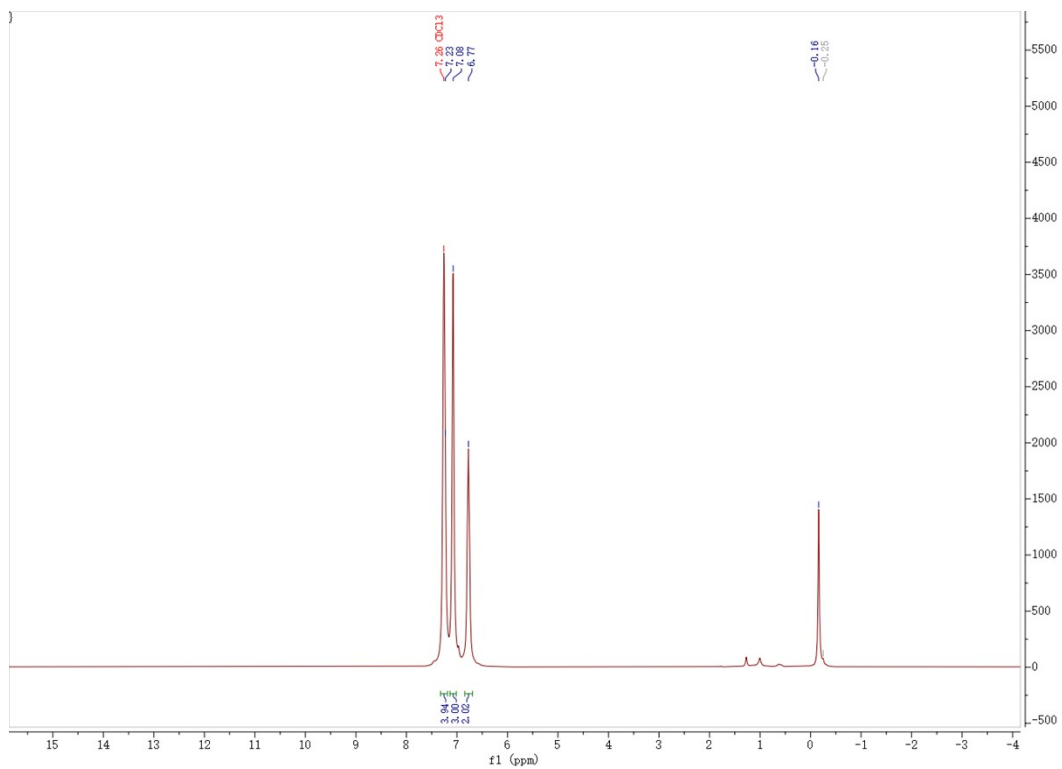

¹H NMR (400 MHz, CDCl₃) of product **3ea**

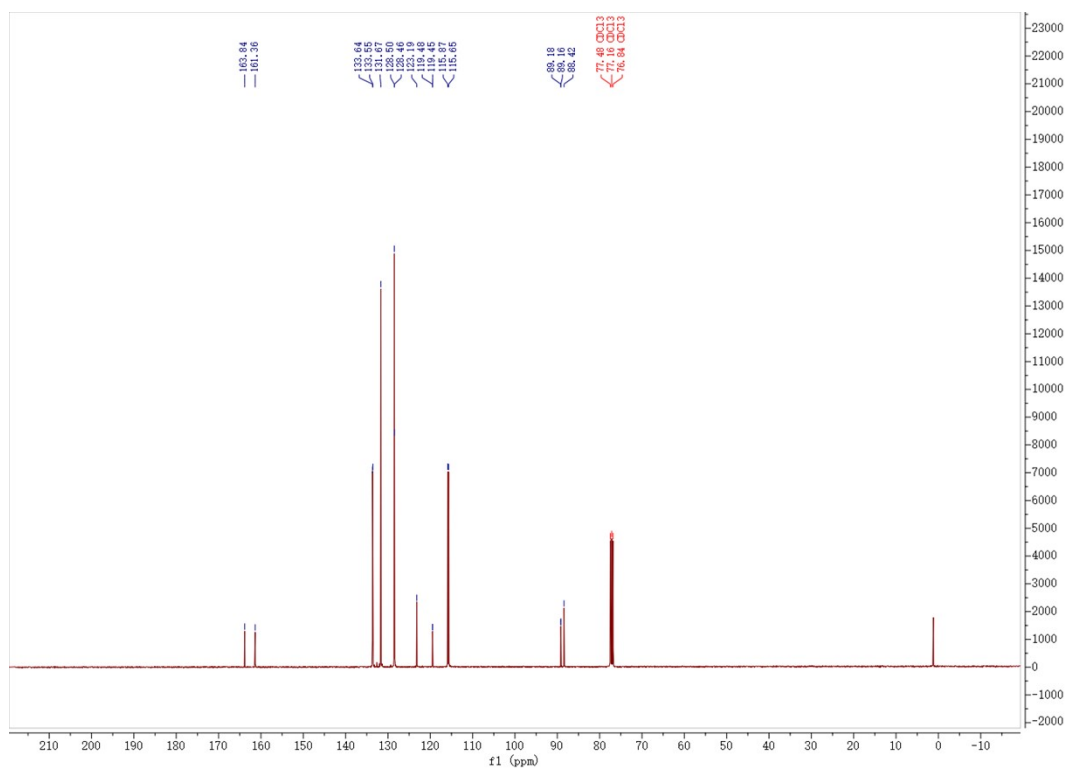

¹³C NMR (101 MHz, CDCl₃) of product **3ea**

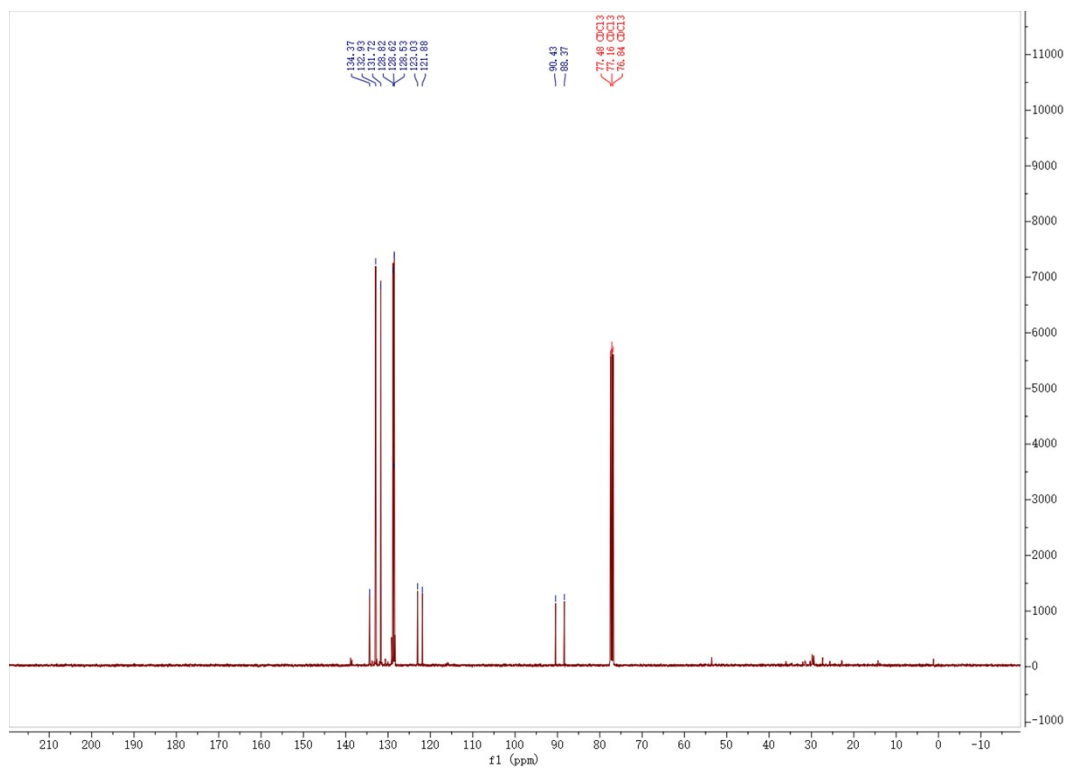

¹³C NMR (101 MHz, CDCl₃) of product **3fa**

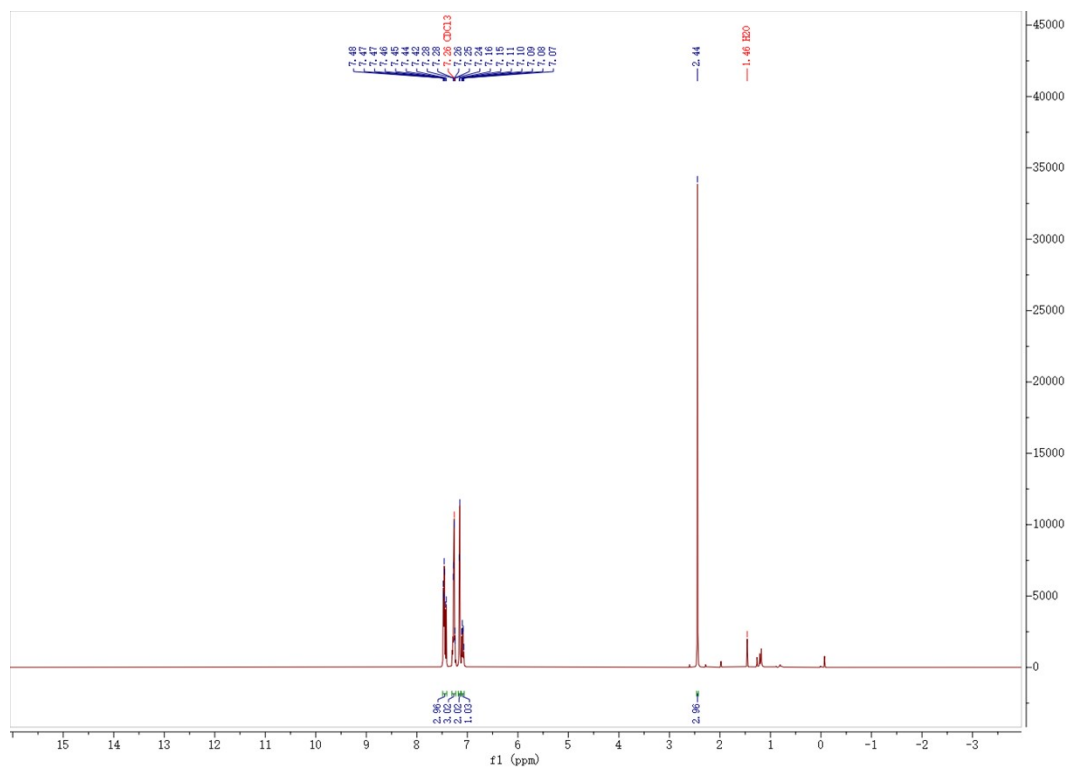

¹H NMR (400 MHz, CDCl₃) of product **3ga**

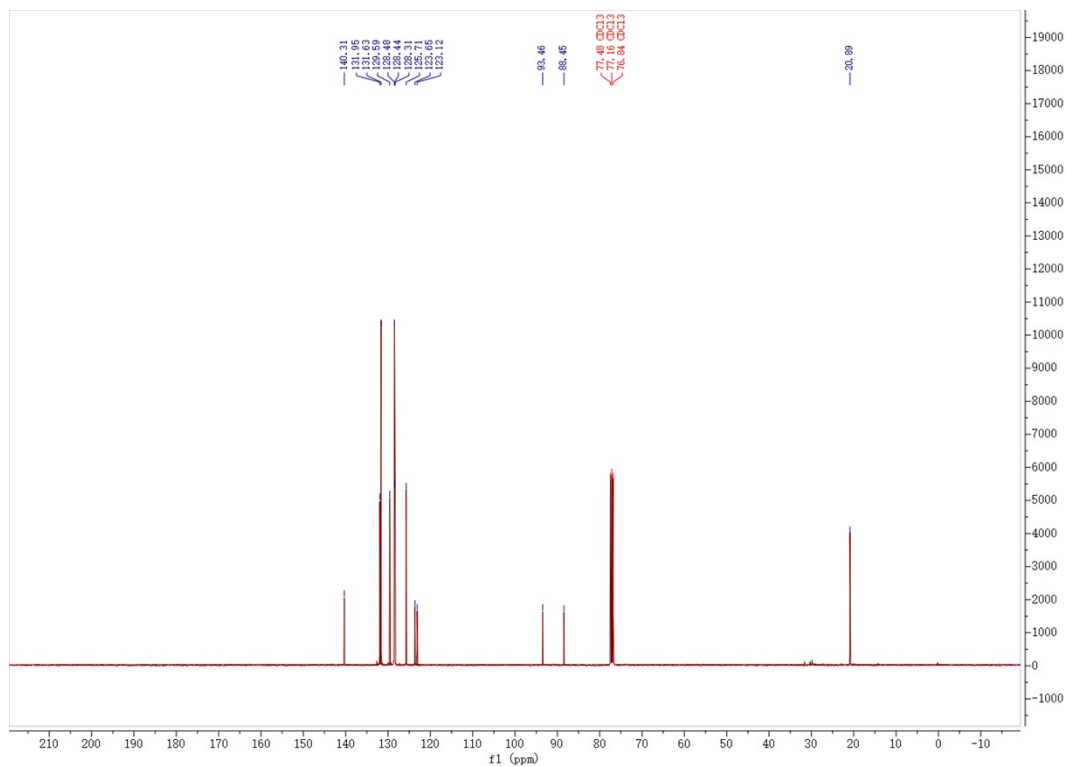

¹³C NMR (101 MHz, CDCl₃) of product **3ga**

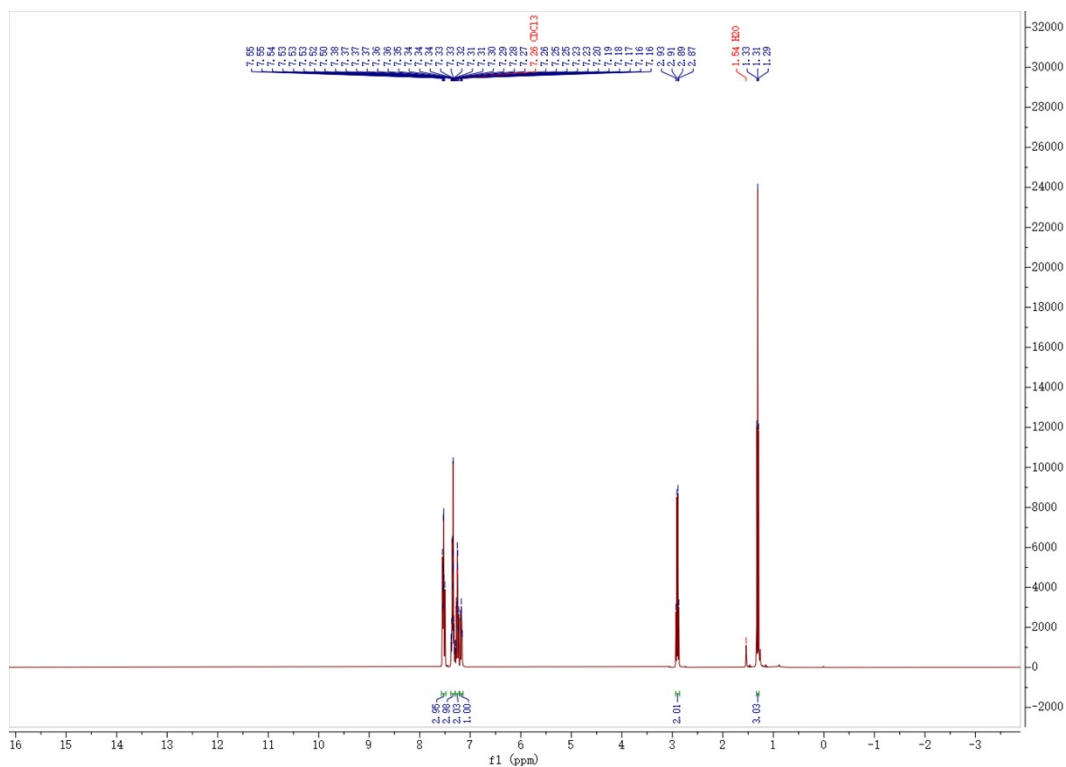

¹H NMR (400 MHz, CDCl₃) of product **3ha**

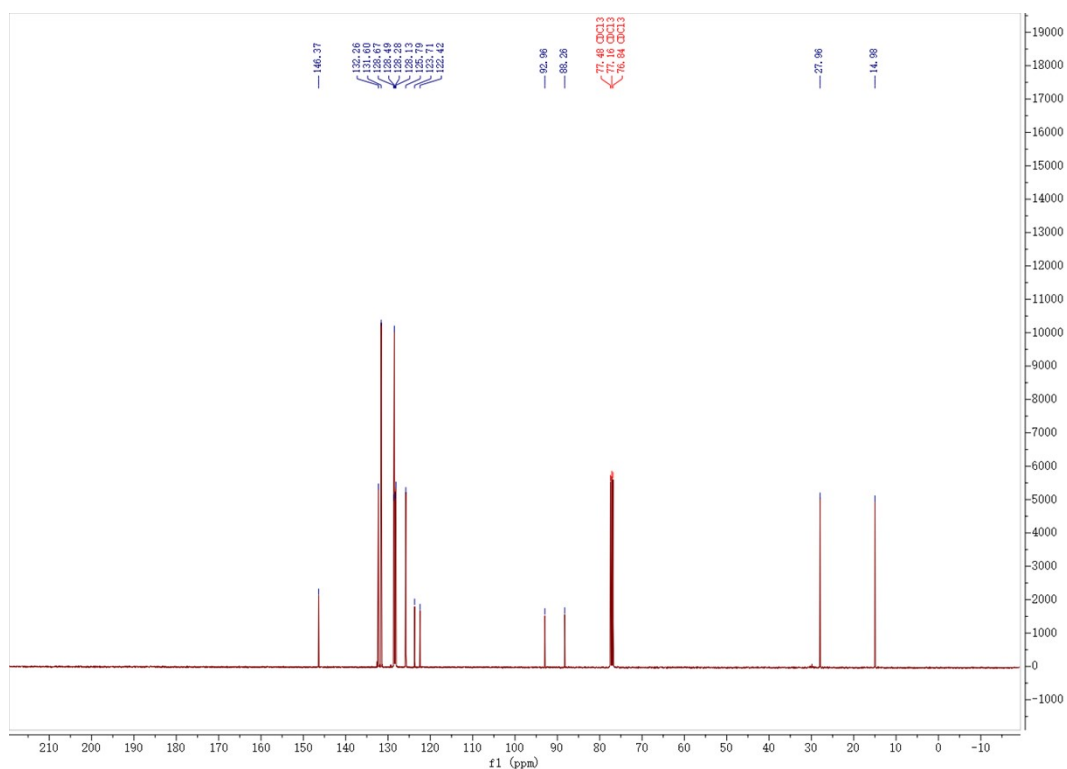

^{13}C NMR (101 MHz, CDCl_3) of product **3ha**

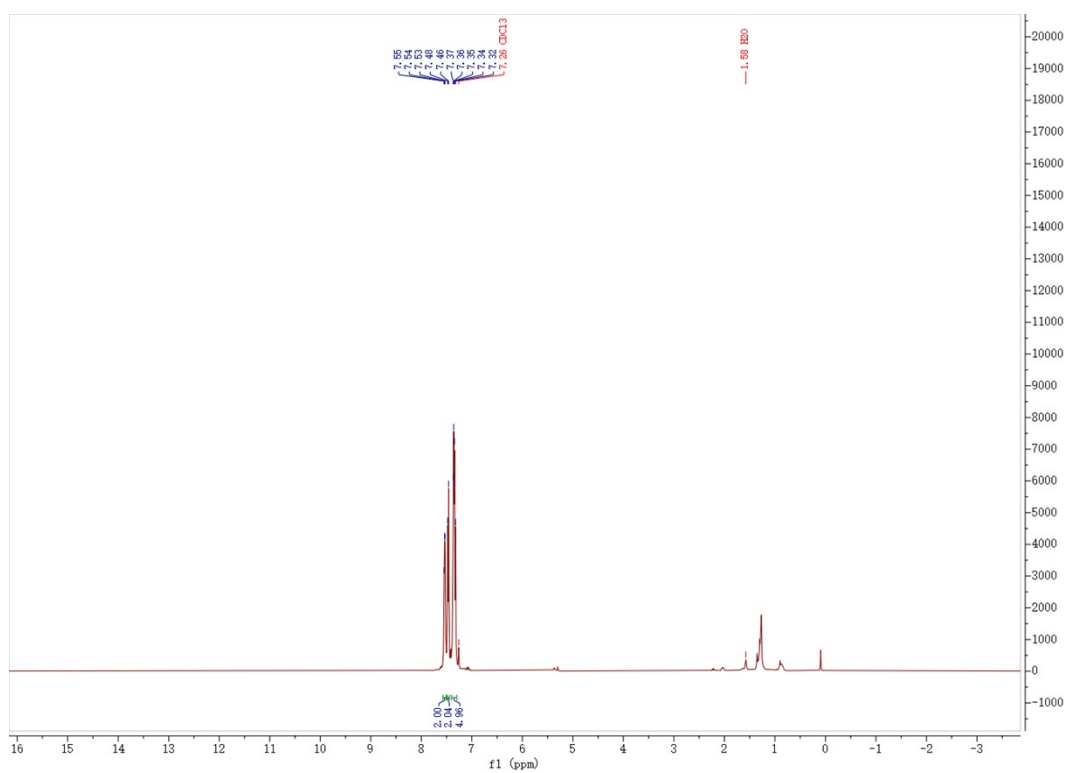

^1H NMR (400 MHz, CDCl_3) of product **3ia**

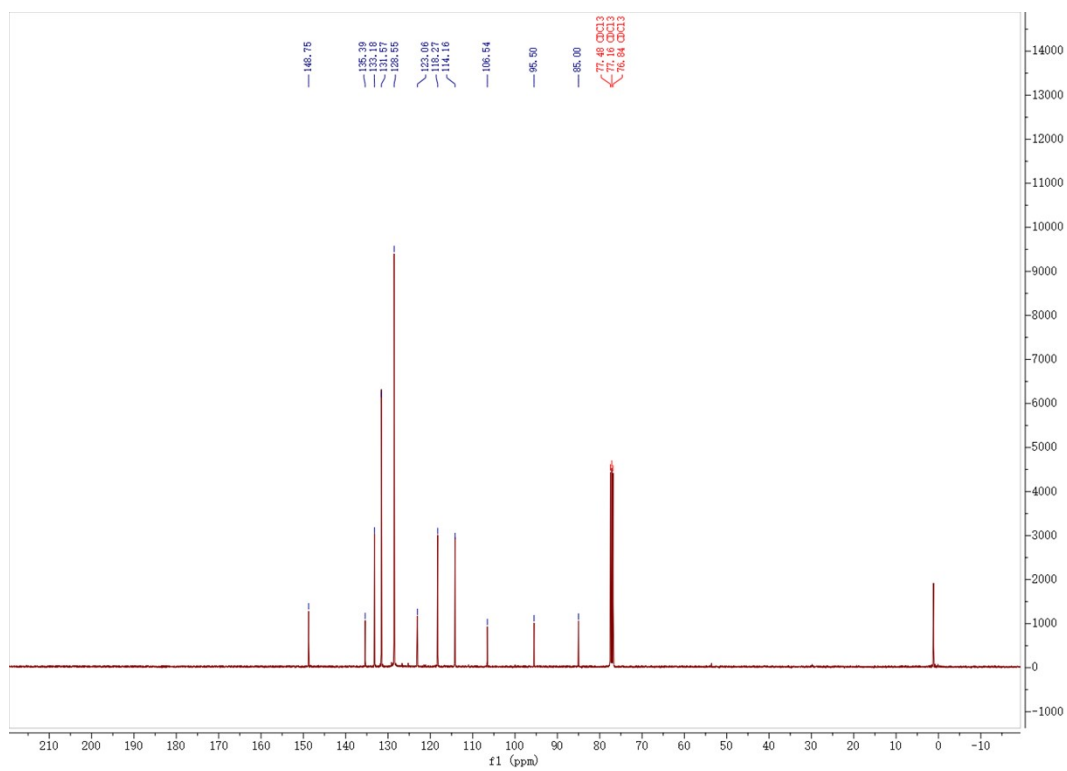

^{13}C NMR (101 MHz, CDCl_3) of product **3ka**



^1H NMR (400 MHz, CDCl_3) of product **3la**

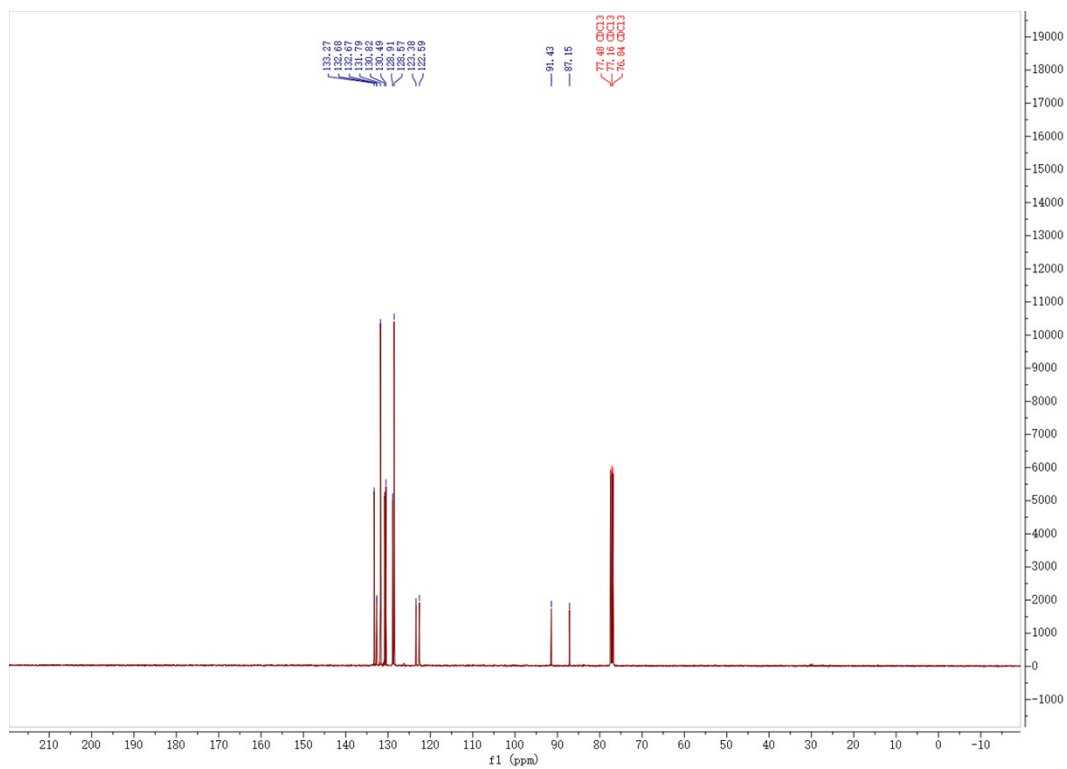

¹³C NMR (101 MHz, CDCl₃) of product **3a**

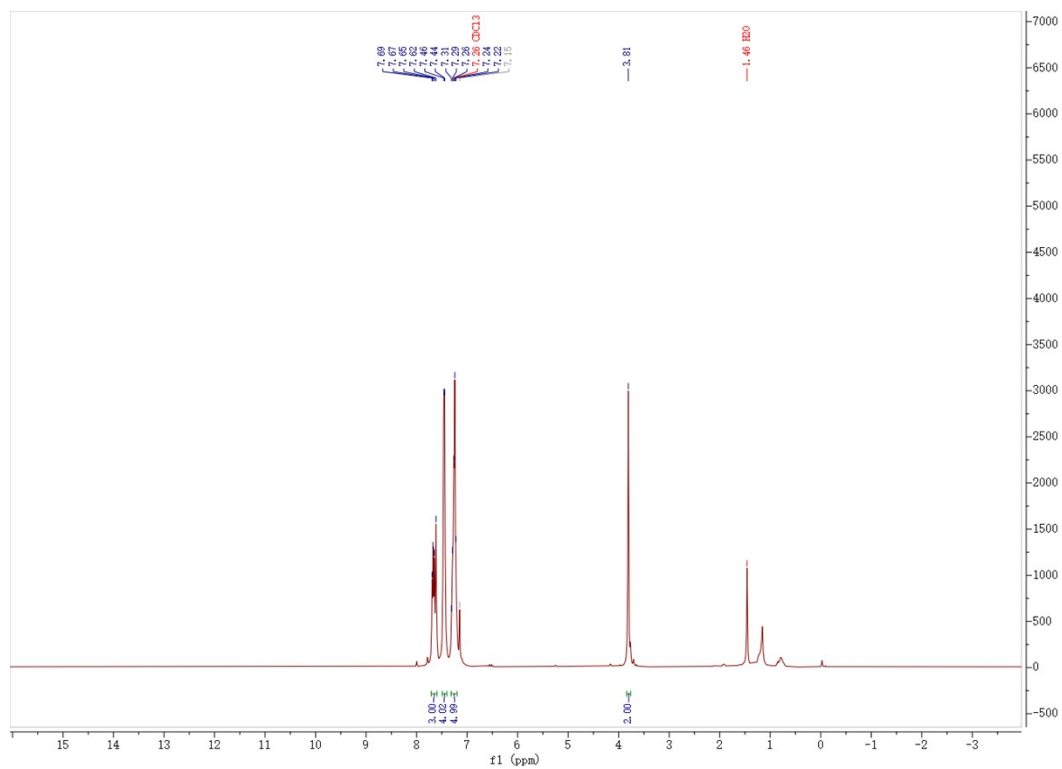

¹H NMR (400 MHz, CDCl₃) of product **3a**

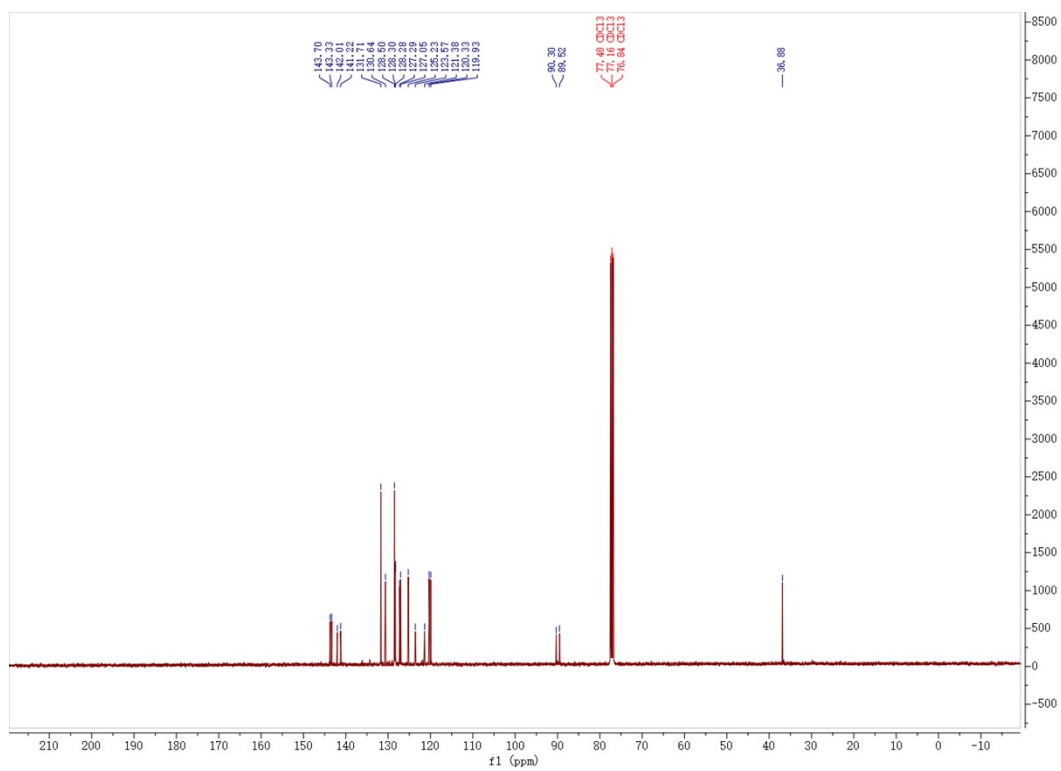

¹³C NMR (101 MHz, CDCl₃) of product **3ma**



¹H NMR (400 MHz, CDCl₃) of product **3cb**



¹³C NMR (101 MHz, CDCl₃) of product **3cb**

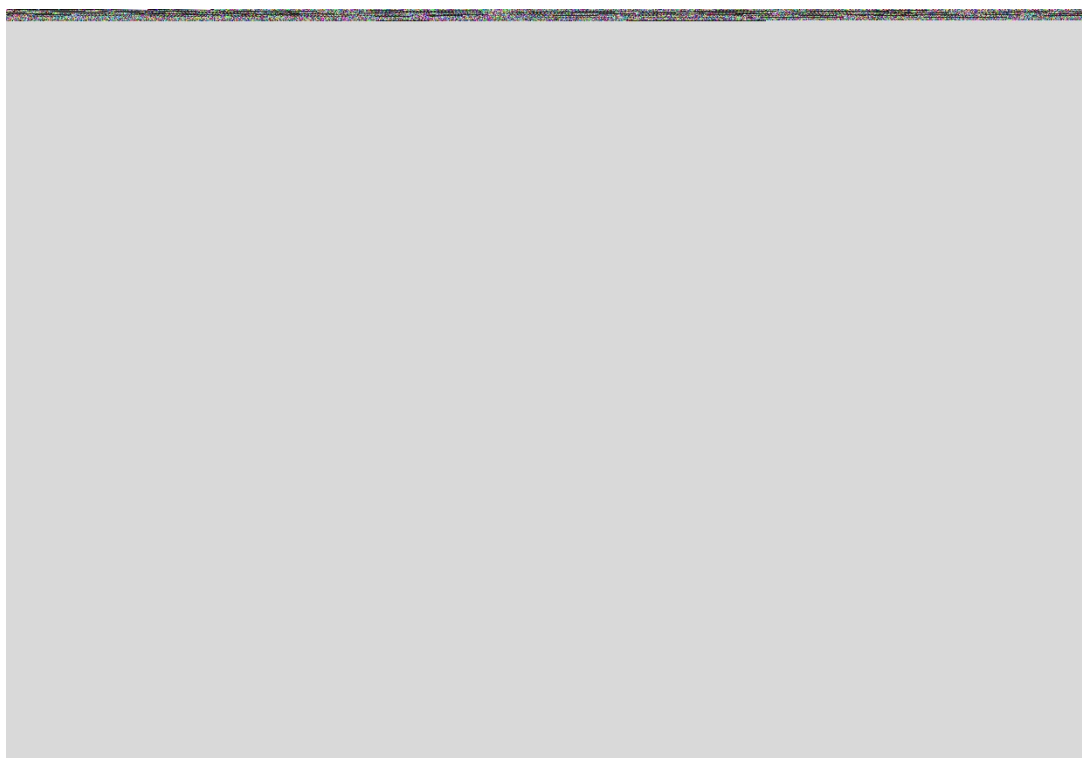

¹⁹F NMR (377 MHz, CDCl₃) of product **3cb**

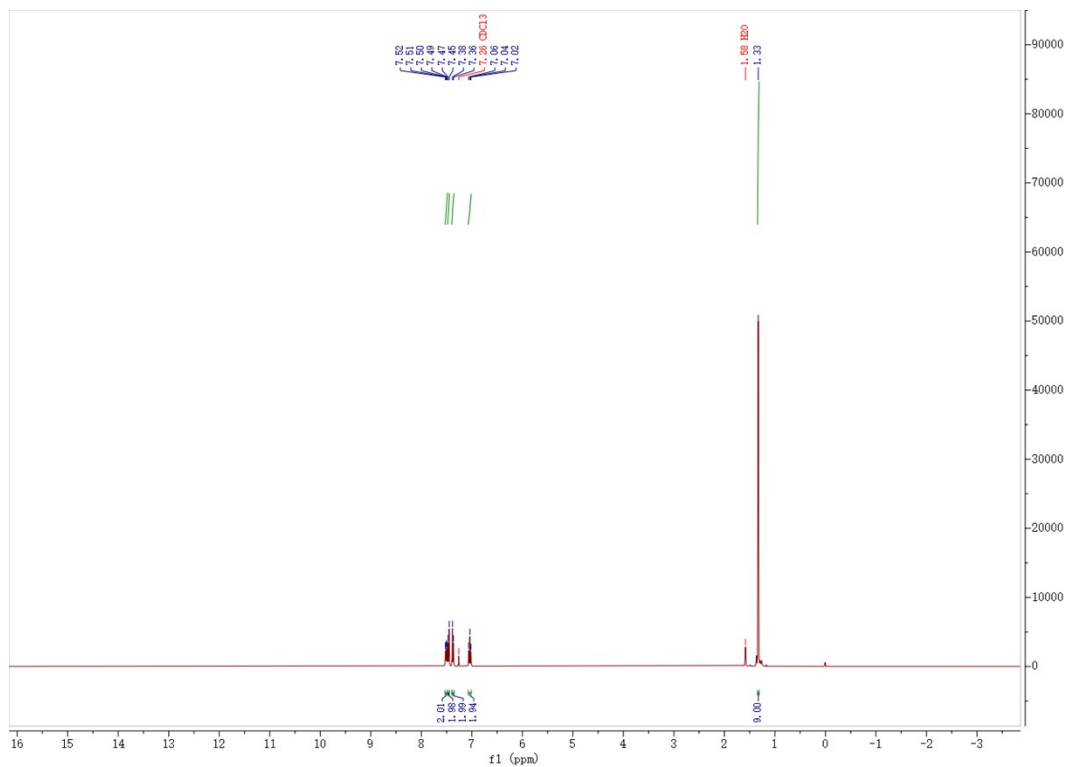

^1H NMR (400 MHz, CDCl_3) of product **3ab**

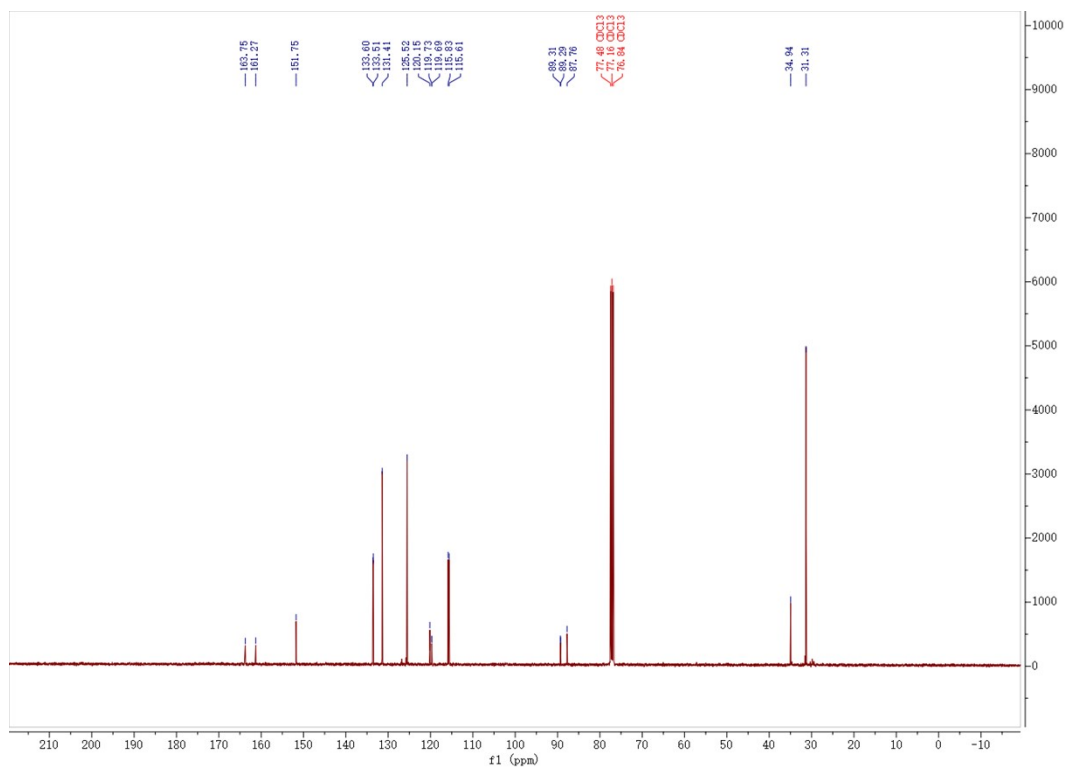

^{13}C NMR (101 MHz, CDCl_3) of product **3ab**

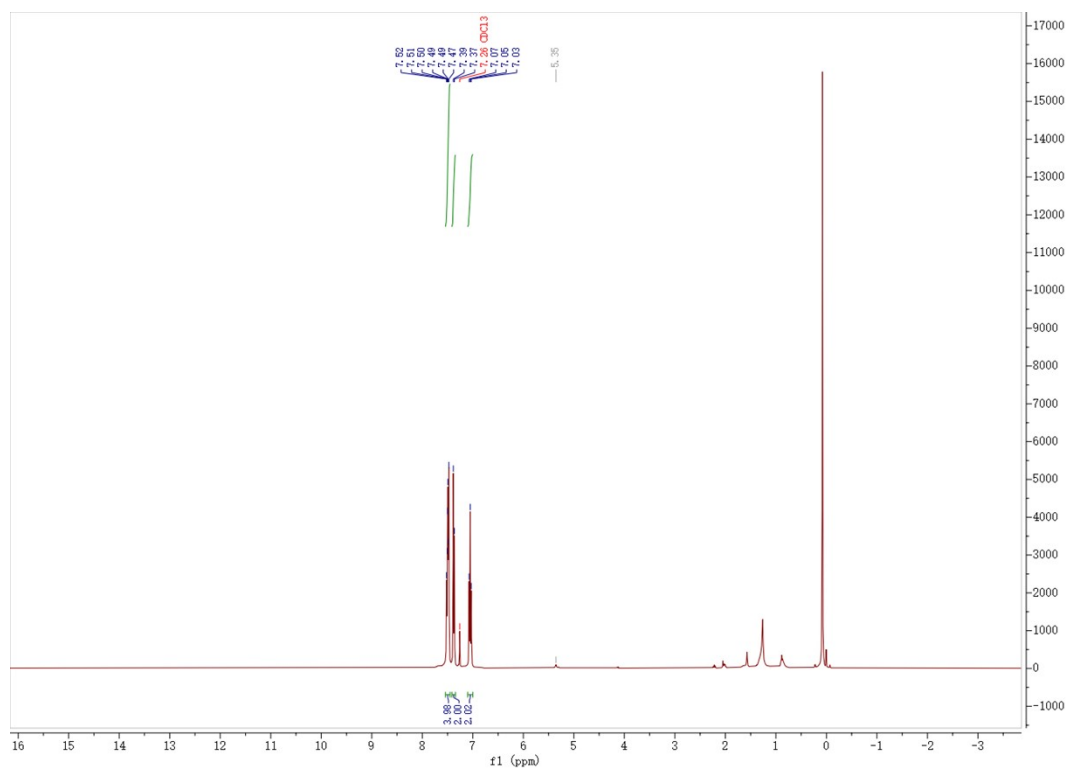

¹H NMR (400 MHz, CDCl₃) of product 3ec

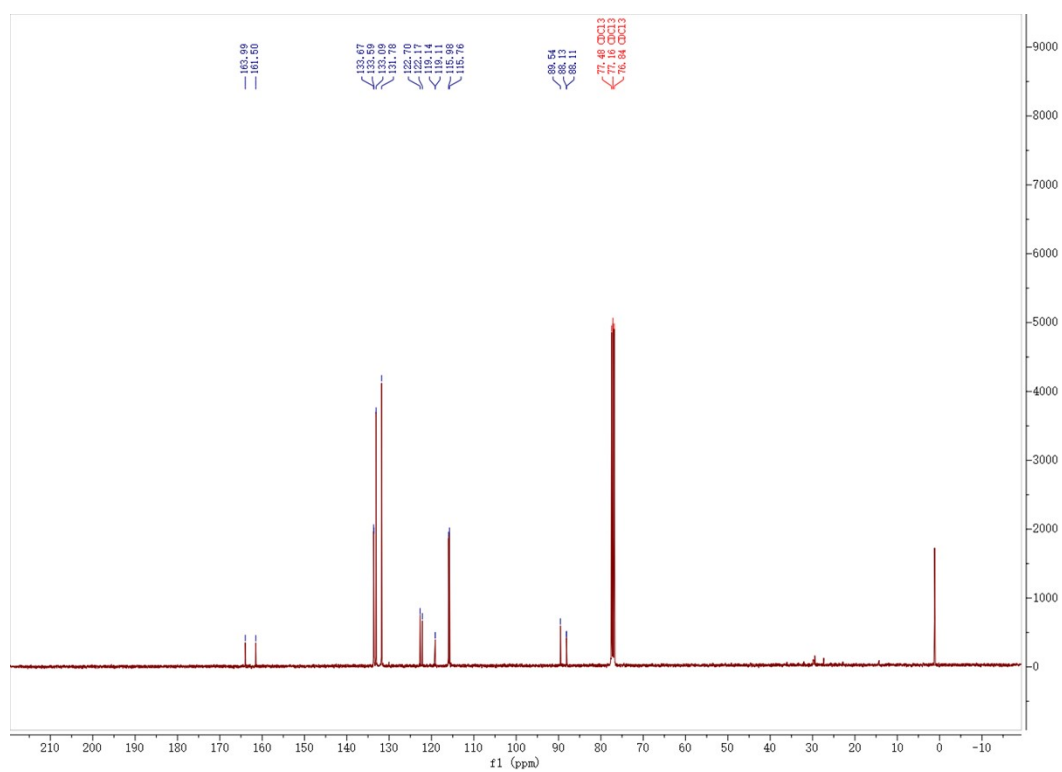

¹³C NMR (101 MHz, CDCl₃) of product 3ec

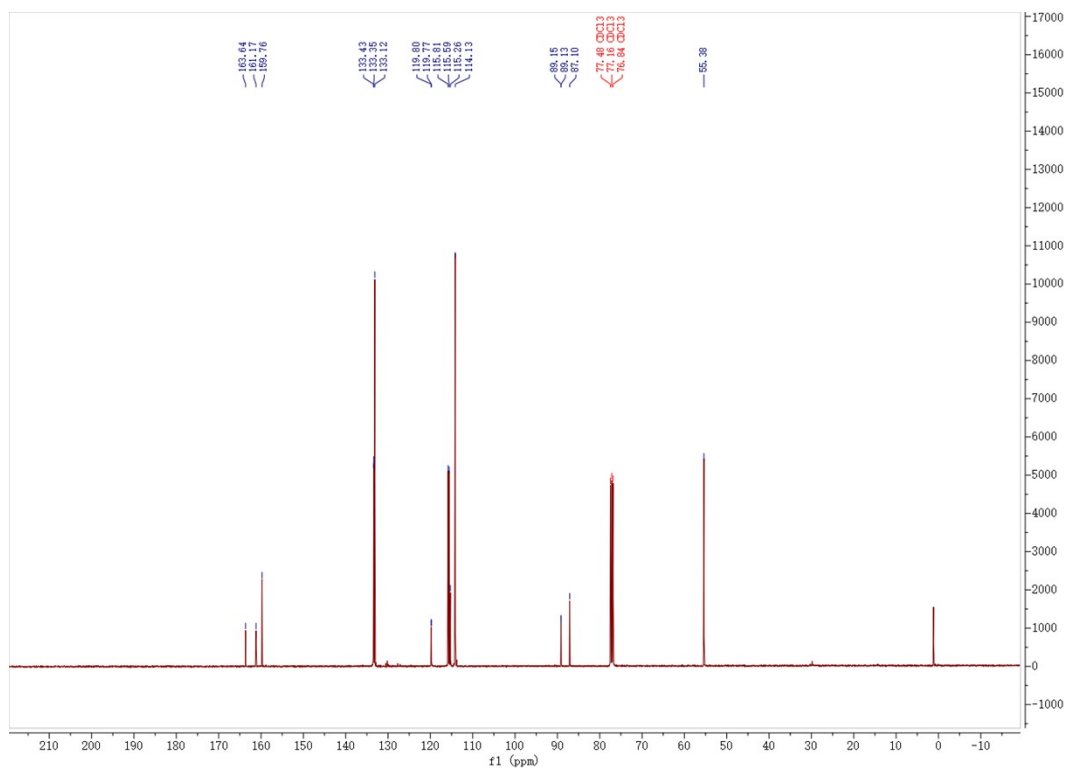

^{13}C NMR (101 MHz, CDCl_3) of product **3ed**

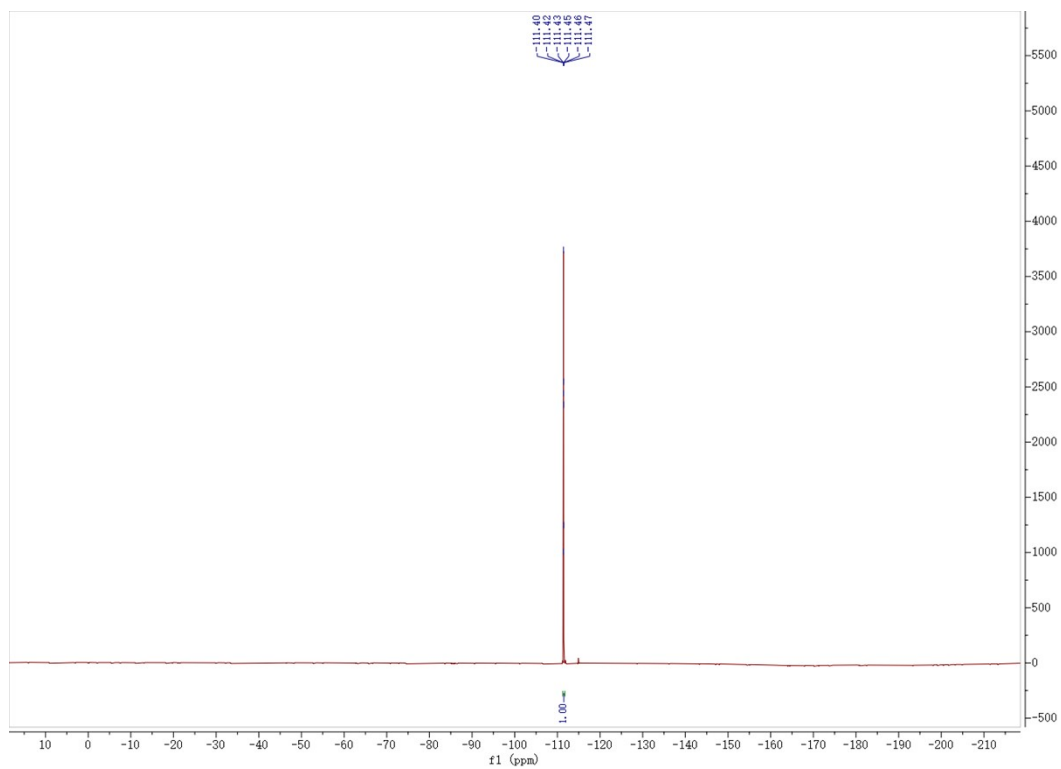

^{19}F NMR (377 MHz, CDCl_3) of product **3ed**

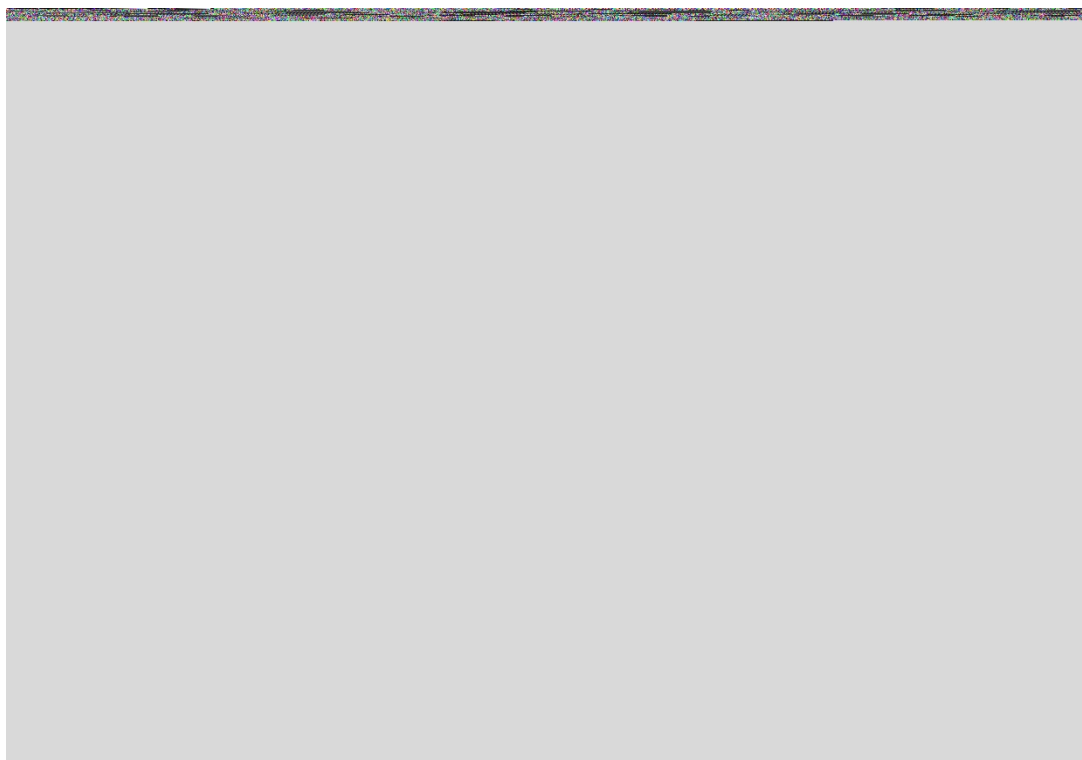

¹H NMR (400 MHz, CDCl₃) of product **3cf**

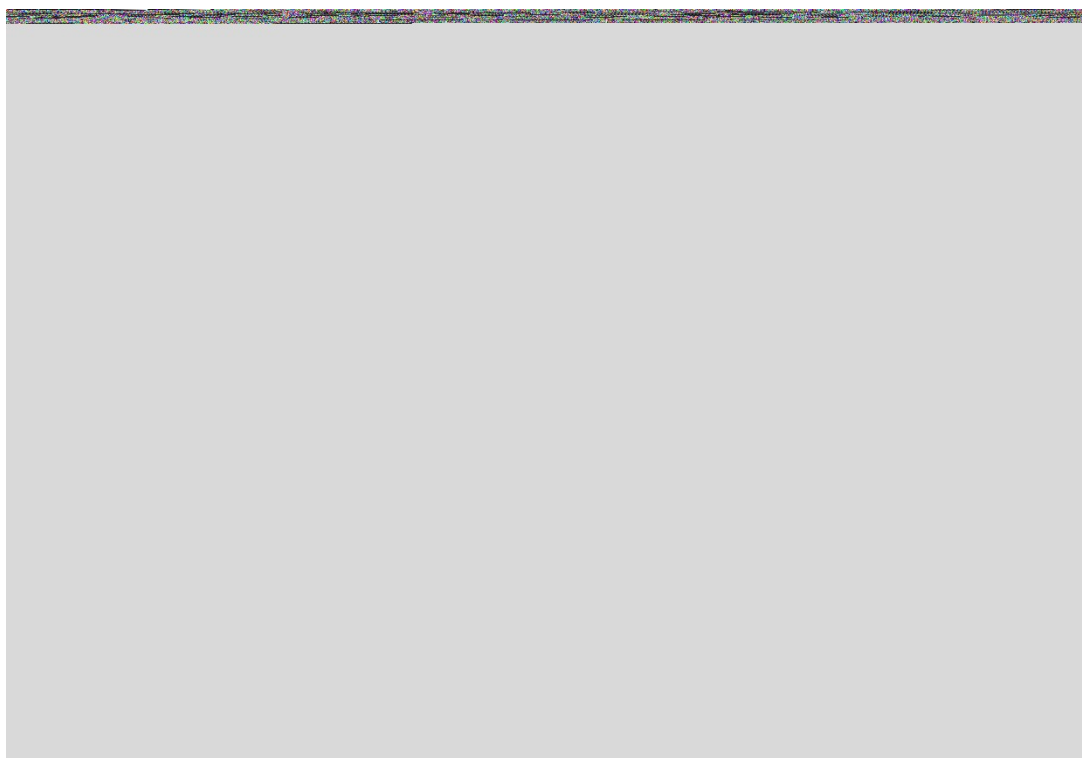

¹³C NMR (101 MHz, CDCl₃) of product **3cf**



¹H NMR (400 MHz, CDCl₃) of product **3cg**



¹³C NMR (101 MHz, CDCl₃) of product **3cg**

