

Supplementary information

Single-Nucleotide Polymorphisms Detection Base on Active-Matrix Digital Microfluidics Pyrosequencing Lab-on- a-chip Platform

Huiting Hu, †^a Tong Wang, †^b Bingbing Zhang,^a Kai Jin,^c Zihan Wang,^d Qi Huang,^c Hanbin Ma,^b Jinhua Li,^{a*} Zhiyao Chen,^{d*} Siyi Hu^{c*}

- a. Nanophotonics and Biophotonics Key Laboratory of Jilin Province, Changchun University of Science and Technology, Changchun, 130022, P.R.China.
- b. Department of Laboratory Medicine, Sichuan Provincial People's Hospital, School of Medicine, University of Electronic Science and Technology of China, Chengdu, Sichuan province, 610072, P.R.China.
- c. CAS Key Laboratory of Bio-medical Diagnostics, Suzhou Institute of Biomedical Engineering and Technology, Chinese Academy of Sciences, No. 88 Keling Road, Suzhou, Jiangsu province, 215163, P.R.China.
- d. Department of Pharmacy, The First Affiliated Hospital of Soochow University, Suzhou, 215006, P.R.China.

Table of Contents

Figure S1. AM-DMF Chip Overall Structure Diagram.

Table S1. The list of Primer sequence.

Figure S2. Schematic diagram of droplet movement area on the chip.

Figure S3. Detection results for nucleotides of varying volumes.

Table S2. The list of SNP detection sequence.

Figure S4. Comparison Chart of Systematic Detection Results for the *CYP2C19*2* Locus Gene and Clinical Outcomes.

Figure S5. Comparison Chart of Systematic Detection Results for the *CYP2C19*3* Locus Gene and Clinical Outcomes.

Table S3. Comparison of actual detection results for clinical samples between the Pyromark Q24 and AM-DMF.

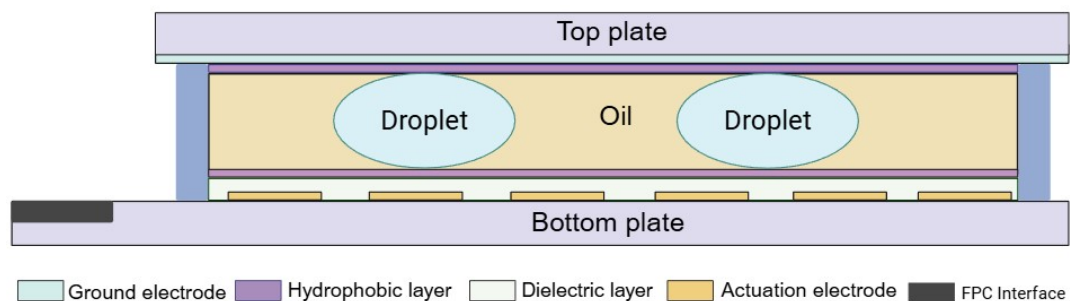

Figure S1. AM-DMF Chip Overall Structure Diagram

Table S1. The list of Primer sequence

Name	Sequence (5'-3')
Forward primer	Biotin – GGC TCT CAT GGA ATG GCT AAA GAC AAG ACC
Reverse primer	TTG TAT ATG AGG CCC ATG CAA CTG GCA AGT G
Sequencing primer	GCA CCA GTT GAA TAG CTT AG

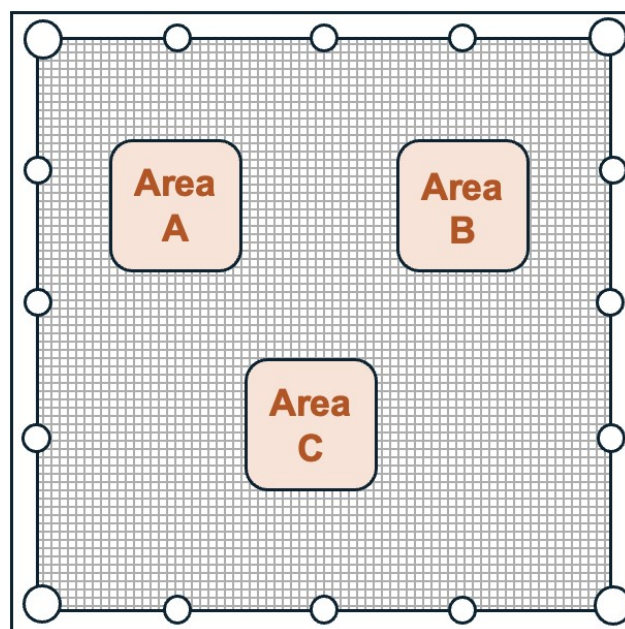

Figure S2. Schematic diagram of droplet movement area on the chip.

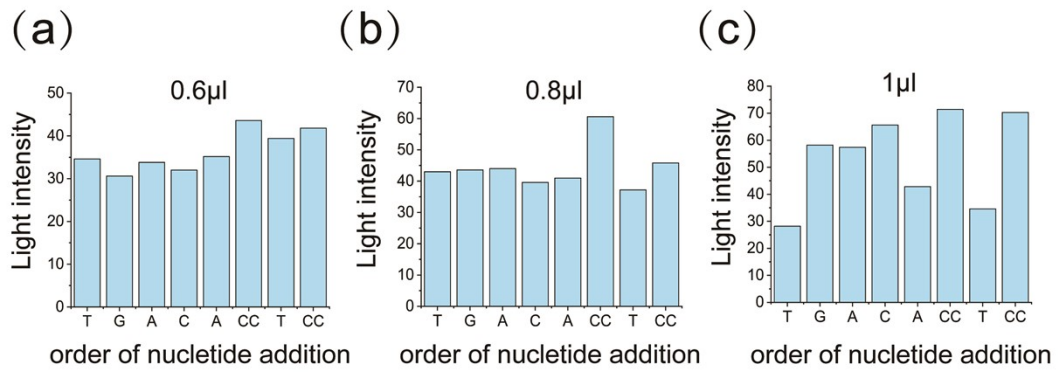

Figure S3. Detection results for nucleotides of varying volumes. (a) Add 0.6 μl of nucleotides. (b) Add 0.8 μl of nucleotides. (c) Add 1 μl of nucleotides.

Table S2. The list of SNP detection sequence

Detection of genetic loci	Sequence (5'-3')
CYP2C19*2 (G681A) rs4244285	CC/T GGG AAA TAA T
CYP2C19*3 (G636A) rs4986893	GG/A ATC CAG GT

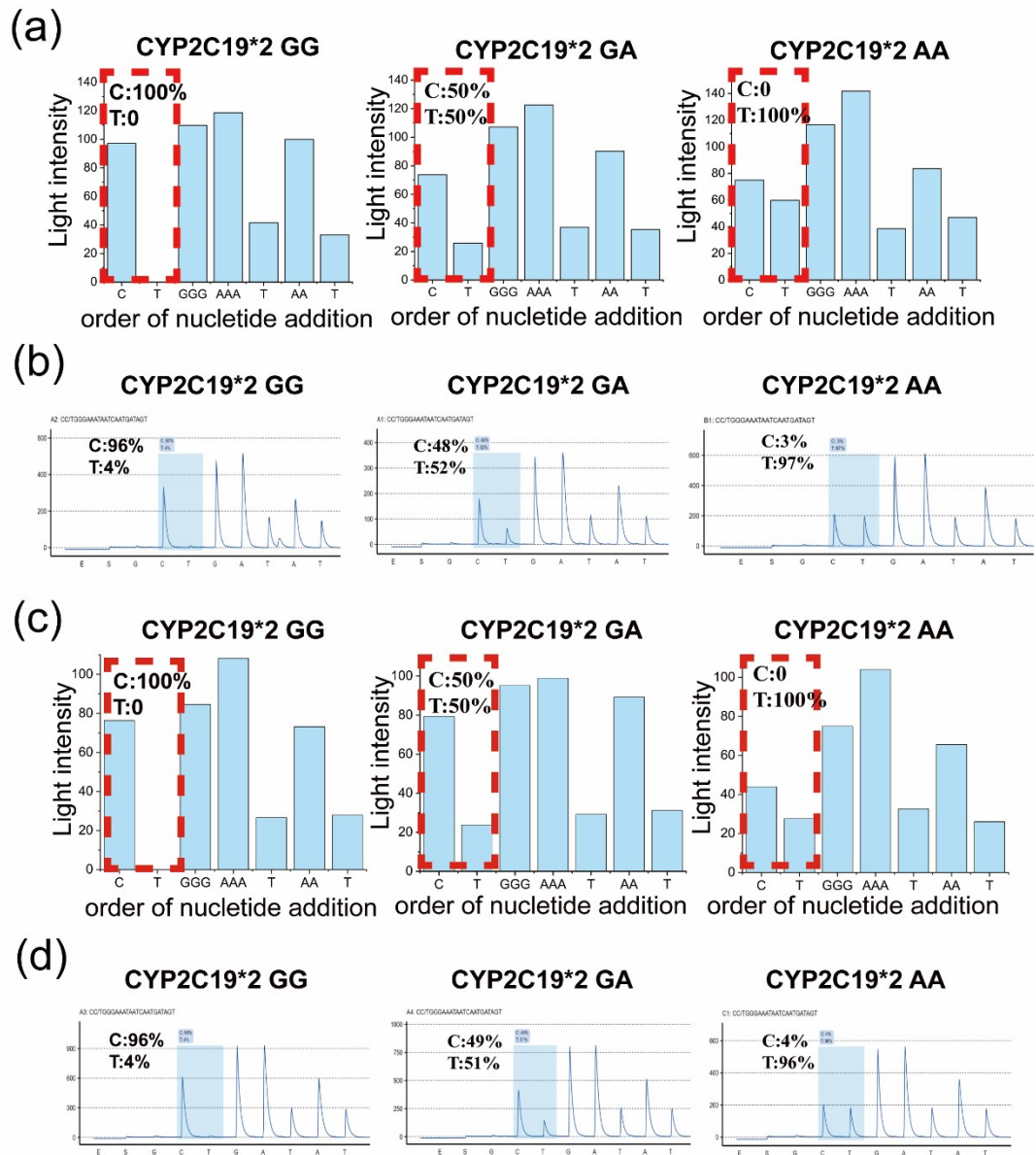

Figure S4. Comparison Chart of Systematic Detection Results for the *CYP2C19*2* Locus Gene and Clinical Outcomes. (a) (c) Systematic detection results for the *CYP2C19*2* locus gene. (b) (d) Clinical testing results for the *CYP2C19*2* gene locus. (The samples used in the system and in clinical practice are identical.)

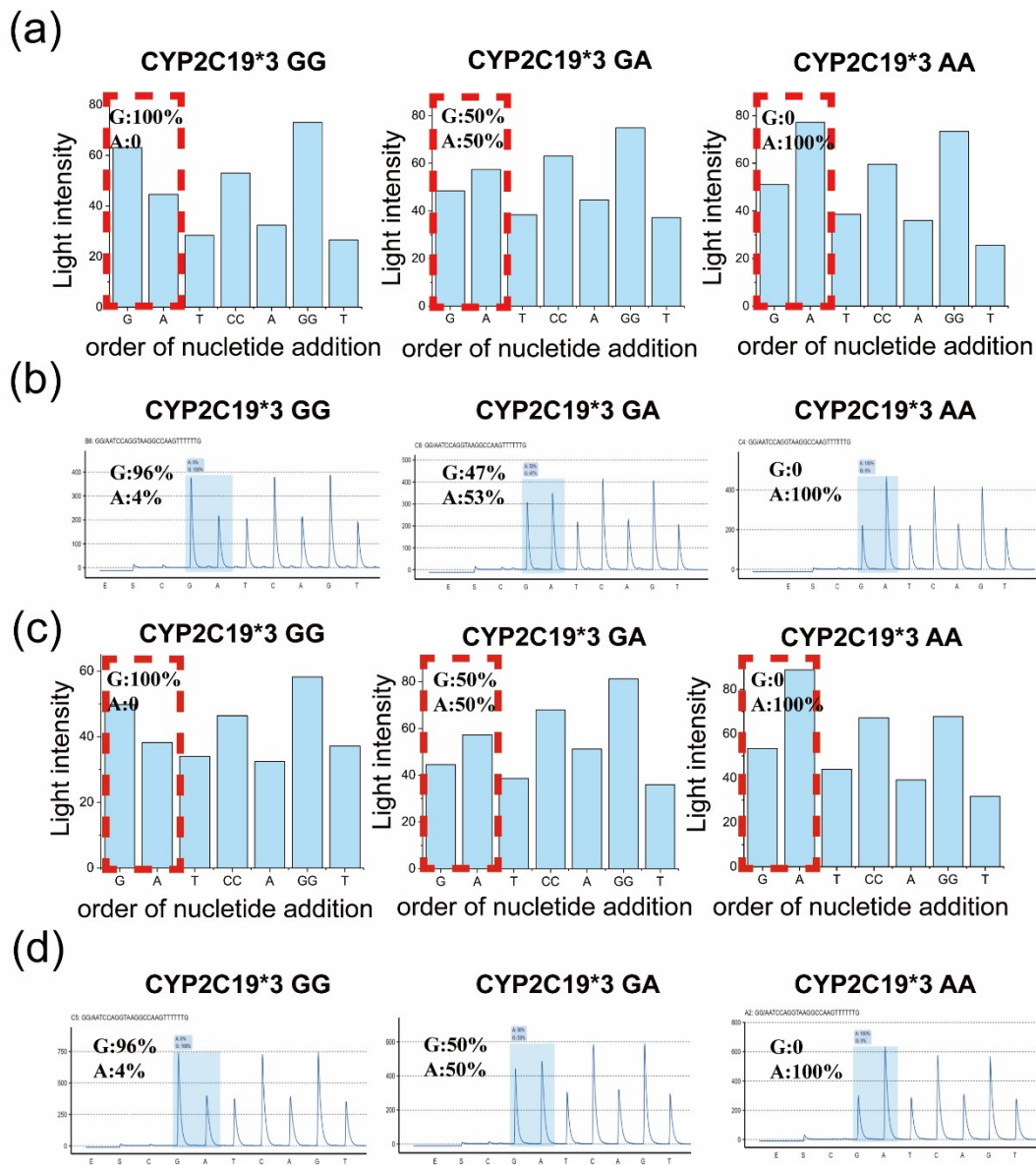

Figure S5. Comparison Chart of Systematic Detection Results for the *CYP2C19*3* Locus Gene and Clinical Outcomes. (a) (c) Systematic detection results for the *CYP2C19*3* locus gene. (b) (d) Clinical testing results for the *CYP2C19*3* gene locus.

(The samples used in the system and in clinical practice are identical.)

Table S3. Comparison of actual detection results for clinical samples between the Pyromark Q24 and AM-DMF

Detection genetic loci	Sample number	Genotype	PyromarkQ24 detection value	AM-DMF detection value
<i>CYP2C19*2</i>	1	GG	C: 96% T: 4%	C: 100% T: 0
	2	GA	C: 48% T: 52%	C: 52% T: 48%
	3	AA	C: 3% T: 97%	C: 18% T: 82%
	4	GG	C: 96% T: 4%	C: 100% T: 0
	5	GA	C: 49% T: 51%	C: 46% T: 54%
	6	AA	C: 4% T: 96%	C: 12% T: 88%
<i>CYP2C19*3</i>	7	GG	G: 96% A: 4%	G: 83% A: 17%
	8	GA	G: 47% A: 53%	G: 46% A: 54%
	9	AA	G: 0 A: 100%	G: 17% A: 83%
	10	GG	G: 96% A: 4%	G: 87% A: 13%
	11	GA	G: 50% A: 50%	G: 44% A: 56%
	12	AA	G: 100% A: 0	G: 87% A: 13%