

1 **Supporting Information for “SimpleBox4nano: Environmental Fate**
2 **Modelling of Nanomaterials via the Enalos Cloud Platform”**

3 Dimitris G. Mintis,^{a, b} Sotiris Kallishis,^{a, b} Panagiotis D. Kolokathis,^{b, c} Andreas Tsoumanis,^{a, b} Georgia
4 Melagraki,^d Joris T.K. Quik,^e J.A.J. Meesters,^f Iseult Lynch,^{b, g} Dario Greco,^{h, i} Antreas Afantitis^{a, b, c, j, *}

5

6 ^a NovaMechanics Ltd., Nicosia 1070, Cyprus

7 ^b Entelos Institute, Nicosia 2102, Cyprus

8 ^c NovaMechanics MIKE, Piraeus 18545, Greece

9 ^d Division of Physical Sciences and Applications, Hellenic Military Academy, Vari 16672, Greece

10 ^e National Institute for Public Health and the Environment (RIVM), Center for Sustainability,
11 Environment and Health (DMG), Antonie van Leeuwenhoeklaan 9, 3721 MA Bilthoven, the Netherlands

12 ^f National Institute for Public Health and Environment (RIVM), Centre for Safety of Substances and
13 Products, Antonie van Leeuwenhoeklaan 9, 3721 MA Bilthoven, the Netherlands

14 ^g School of Geography, Earth and Environmental Sciences, University of Birmingham, Birmingham B15
15 2TT, United Kingdom

16 ^h Finnish Hub for Development and Validation of Integrated Approaches (FHAIIVE), Faculty of Medicine
17 and Health Technology, Tampere University, Tampere 33100, Finland

18 ⁱ Division of Pharmaceutical Biosciences, Faculty of Pharmacy, University of Helsinki, Helsinki 00790,
19 Finland

20 ^j Department of Pharmacy, Frederick University, Nicosia 1036, Cyprus

21

22 **S1. Comparison of steady-state mass and concentration calculations using SimpleBox4nano (v4.01-**
 23 **nano) in Excel and the *SimpleBox4nano* web application**

24

25 **Table S1. Comparison of steady-state mass and concentration calculations for nZnO, using SimpleBox4nano (v4.01-nano)**
 26 **in Excel and the *SimpleBox4nano* web application under default scenarios within the regional scale (all values are**
 27 **rounded to one decimal point).**

nZnO					
Receiving Compartment	SimpleBox4nano (v4.01-nano) in Excel		SimpleBox4nano		Concentration Units
	Masses (kg)	Concentrations	Masses (kg)	Concentrations	
Air	5.6E+04	2.5E-07	5.6E+04	2.5E-07	g.m ⁻³
Dissolved/Gas species (G/D)	2.0E+04	8.6E-08	2.0E+04	8.6E-08	g.m ⁻³
* GAS PHASE	8.4E-09	3.7E-20	8.4E-09	3.7E-20	g.m ⁻³
* AEROSOL- and CLOUD PHASES	2.0E+04	8.6E-08	2.0E+04	8.6E-08	g.m ⁻³
Solid species (S)	7.1E+03	3.1E-08	7.1E+03	3.1E-08	g.m ⁻³
Species attached to NCs (<450 nm) (A)	3.0E+04	1.3E-07	3.0E+04	1.3E-07	g.m ⁻³
Species attached to suspended particles (>450 nm) (P)	2.0E-01	8.9E-13	2.0E-01	8.9E-13	g.m ⁻³
Fresh water lake	1.8E+04	3.1E-07	1.8E+04	3.1E-07	g.L ⁻¹
Dissolved/Gas species (G/D)	1.8E+04	3.1E-07	1.8E+04	3.1E-07	g.L ⁻¹
* DISSOLVED	1.8E+04	3.1E-07	1.8E+04	3.1E-07	g.L ⁻¹
* SUSPENDED SOLIDS	4.8E+00	3.1E-05	4.8E+00	3.1E-05	g.kg(d) ⁻¹
Solid species (S)	7.1E-02	1.2E-12	7.1E-02	1.2E-12	g.L ⁻¹
Species attached to NCs (<450 nm) (A)	5.5E+01	9.7E-10	5.5E+01	9.7E-10	g.L ⁻¹
Species attached to suspended particles (>450 nm) (P)	2.7E-02	4.7E-13	2.7E-02	4.7E-13	g.L ⁻¹
Fresh water lake sediment	5.1E+02	2.3E-05	5.1E+02	2.3E-05	g.kg(w) ⁻¹
Dissolved/Gas species (G/D)	5.1E+02	2.3E-05	5.1E+02	2.3E-05	g.kg(w) ⁻¹
* PORE WATER	4.1E+02	1.1E-03	4.1E+02	1.1E-03	g.L ⁻¹
* SOLID PHASE	1.0E+02	5.7E-02	1.0E+02	5.7E-02	g.kg(d) ⁻¹
Solid species (S)	1.5E-07	6.6E-15	1.5E-07	6.6E-15	g.kg(w) ⁻¹
Species attached to NCs (<450 nm) (A)	4.1E-02	1.8E-09	4.1E-02	1.8E-09	g.kg(w) ⁻¹
Species attached to suspended particles (>450 nm) (P)	7.8E-03	3.5E-10	7.8E-03	3.5E-10	g.kg(w) ⁻¹
Fresh water	1.9E+07	1.0E-03	1.9E+07	1.0E-03	g.L ⁻¹
Dissolved/Gas species (G/D)	1.9E+07	1.0E-03	1.9E+07	1.0E-03	g.L ⁻¹

* DISSOLVED	1.9E+07	1.0E-03	1.9E+07	1.0E-03	g.L ⁻¹
* SUSPENDED SOLIDS	3.3E+04	1.0E-01	3.3E+04	1.0E-01	g.kg(d) ⁻¹
Solid species (S)	8.8E+02	4.7E-08	8.8E+02	4.7E-08	g.L ⁻¹
Species attached to NCs (<450 nm) (A)	1.5E+05	8.2E-06	1.5E+05	8.2E-06	g.L ⁻¹
Species attached to suspended particles (>450 nm) (P)	5.2E+03	2.8E-07	5.2E+03	2.8E-07	g.L ⁻¹
Fresh water sediment	8.5E+06	3.5E-02	8.5E+06	3.5E-02	g.kg(w) ⁻¹
Dissolved/Gas species (G/D)	8.4E+06	3.4E-02	8.4E+06	3.4E-02	g.kg(w) ⁻¹
* PORE WATER	6.7E+06	1.7E+00	6.7E+06	1.7E+00	g.L ⁻¹
* SOLID PHASE	1.7E+06	8.7E+01	1.7E+06	8.7E+01	g.kg(d) ⁻¹
Solid species (S)	6.1E-02	2.5E-10	6.1E-02	2.5E-10	g.kg(w) ⁻¹
Species attached to NCs (<450 nm) (A)	3.7E+03	1.5E-05	3.7E+03	1.5E-05	g.kg(w) ⁻¹
Species attached to suspended particles (>450 nm) (P)	5.0E+04	2.0E-04	5.0E+04	2.0E-04	g.kg(w) ⁻¹
Surface sea/ocean water	5.4E+06	5.4E-04	5.4E+06	5.4E-04	g.L ⁻¹
Dissolved/Gas species (G/D)	5.4E+06	5.4E-04	5.4E+06	5.4E-04	g.L ⁻¹
* DISSOLVED	5.4E+06	5.4E-04	5.4E+06	5.4E-04	g.L ⁻¹
* SUSPENDED SOLIDS	3.9E+03	5.4E-02	3.9E+03	5.4E-02	g.kg(d) ⁻¹
Solid species (S)	2.1E-01	2.1E-11	2.1E-01	2.1E-11	g.L ⁻¹
Species attached to NCs (<450 nm) (A)	3.8E+03	3.8E-07	3.8E+03	3.8E-07	g.L ⁻¹
Species attached to suspended particles (>450 nm) (P)	6.5E+01	6.5E-09	6.5E+01	6.5E-09	g.L ⁻¹
Marine sediment	5.9E+05	1.5E-02	5.9E+05	1.5E-02	g.kg(w) ⁻¹
Dissolved/Gas species (G/D)	5.9E+05	1.5E-02	5.9E+05	1.5E-02	g.kg(w) ⁻¹
* PORE WATER	4.7E+05	7.6E-04	4.7E+05	7.6E-04	g.L ⁻¹
* SOLID PHASE	1.2E+05	3.8E-02	1.2E+05	3.8E-02	g.kg(d) ⁻¹
Solid species (S)	8.7E-07	2.2E-14	8.7E-07	2.2E-14	g.kg(w) ⁻¹
Species attached to NCs (<450 nm) (A)	2.8E+01	7.1E-07	2.8E+01	7.1E-07	g.kg(w) ⁻¹
Species attached to suspended particles (>450 nm) (P)	1.9E+02	4.8E-06	1.9E+02	4.8E-06	g.kg(w) ⁻¹
Natural soil	8.6E+06	1.6E-03	8.6E+06	1.6E-03	g.kg(w) ⁻¹
Dissolved/Gas species (G/D)	8.6E+06	1.6E-03	8.6E+06	1.6E-03	g.kg(w) ⁻¹
* PORE WATER	5.7E+04	9.2E-05	5.7E+04	9.2E-05	g.L ⁻¹
* SOLID PHASE	8.5E+06	1.8E-03	8.5E+06	1.8E-03	g.kg(d) ⁻¹

Solid species (S)	7.6E-02	1.5E-11	7.6E-02	1.5E-11	g.kg(w) ⁻¹
Species attached to NCs (<450 nm) (A)	3.6E+03	6.8E-07	3.6E+03	6.8E-07	g.kg(w) ⁻¹
Species attached to suspended particles (>450 nm) (P)	4.1E+02	7.8E-08	4.1E+02	7.8E-08	g.kg(w) ⁻¹
Agricultural soil	3.3E+08	7.1E-03	3.3E+08	7.1E-03	g.kg(w) ⁻¹
Dissolved/Gas species (G/D)	3.3E+08	7.1E-03	3.3E+08	7.1E-03	g.kg(w) ⁻¹
* PORE WATER	2.2E+06	4.0E-04	2.2E+06	4.0E-04	g.L ⁻¹
* SOLID PHASE	3.3E+08	8.0E-03	3.3E+08	8.0E-03	g.kg(d) ⁻¹
Solid species (S)	2.7E+01	5.9E-10	2.7E+01	5.9E-10	g.kg(w) ⁻¹
Species attached to NCs (<450 nm) (A)	1.7E+05	3.6E-06	1.7E+05	3.6E-06	g.kg(w) ⁻¹
Species attached to suspended particles (>450 nm) (P)	1.5E+05	3.2E-06	1.5E+05	3.2E-06	g.kg(w) ⁻¹
Other soil	3.2E+06	1.6E-03	3.2E+06	1.6E-03	g.kg(w) ⁻¹
Dissolved/Gas species (G/D)	3.2E+06	1.6E-03	3.2E+06	1.6E-03	g.kg(w) ⁻¹
* PORE WATER	2.1E+04	9.2E-05	2.1E+04	9.2E-05	g.L ⁻¹
* SOLID PHASE	3.2E+06	1.8E-03	3.2E+06	1.8E-03	g.kg(d) ⁻¹
Solid species (S)	2.8E-02	1.5E-11	2.8E-02	1.5E-11	g.kg(w) ⁻¹
Species attached to NCs (<450 nm) (A)	1.3E+03	6.8E-07	1.3E+03	6.8E-07	g.kg(w) ⁻¹
Species attached to suspended particles (>450 nm) (P)	1.5E+02	7.8E-08	1.5E+02	7.8E-08	g.kg(w) ⁻¹
Total D	3.8E+08	1.6E-06	3.8E+08	1.6E-06	g.L ⁻¹
Total S	8.0E+03	3.5E-11	8.0E+03	3.5E-11	g.L ⁻¹
Total A	3.6E+05	1.6E-09	3.6E+05	1.6E-09	g.L ⁻¹
Total P	2.0E+05	8.8E-10	2.0E+05	8.8E-10	g.L ⁻¹
Total	3.8E+08	1.6E-06	3.8E+08	1.6E-06	g.L ⁻¹

28

29

30 Table S2. Comparison of steady-state mass and concentration calculations for nZnO, using SimpleBox4nano (v4.01-nano)
 31 in Excel and the SimpleBox4nano web application under default scenarios within the continental scale (all values are
 32 rounded to one decimal point).

nZnO					
Receiving Compartment	SimpleBox4nano (v4.01-nano) in Excel		SimpleBox4nano		Concentration Units
	Masses (kg)	Concentrations	Masses (kg)	Concentrations	
Air	1.7E+05	2.3E-08	1.7E+05	2.3E-08	g.m ⁻³
Dissolved/Gas species (G/D)	2.0E+04	2.7E-09	2.0E+04	2.7E-09	g.m ⁻³
* GAS PHASE	8.4E-09	1.2E-21	8.4E-09	1.2E-21	g.m ⁻³
* AEROSOL- and CLOUD PHASES	2.0E+04	2.7E-09	2.0E+04	2.7E-09	g.m ⁻³
Solid species (S)	1.8E+03	2.5E-10	1.8E+03	2.5E-10	g.m ⁻³
Species attached to NCs (<450 nm) (A)	1.5E+05	2.0E-08	1.5E+05	2.0E-08	g.m ⁻³
Species attached to suspended particles (>450 nm) (P)	8.1E-02	1.1E-14	8.1E-02	1.1E-14	g.m ⁻³
Fresh water lake	1.6E+05	1.7E-07	1.6E+05	1.7E-07	g.L ⁻¹
Dissolved/Gas species (G/D)	1.6E+05	1.7E-07	1.6E+05	1.7E-07	g.L ⁻¹
* DISSOLVED	1.6E+05	1.7E-07	1.6E+05	1.7E-07	g.L ⁻¹
* SUSPENDED SOLIDS	4.3E+01	1.7E-05	4.3E+01	1.7E-05	g.kg(d) ⁻¹
Solid species (S)	9.2E-03	1.0E-14	9.2E-03	1.0E-14	g.L ⁻¹
Species attached to NCs (<450 nm) (A)	1.2E+02	1.3E-10	1.2E+02	1.3E-10	g.L ⁻¹
Species attached to suspended particles (>450 nm) (P)	4.2E-03	4.6E-15	4.2E-03	4.6E-15	g.L ⁻¹
Fresh water lake sediment	4.3E+03	1.2E-05	4.3E+03	1.2E-05	g.kg(w) ⁻¹
Dissolved/Gas species (G/D)	4.3E+03	1.2E-05	4.3E+03	1.2E-05	g.kg(w) ⁻¹
* PORE WATER	3.5E+03	6.0E-04	3.5E+03	6.0E-04	g.L ⁻¹
* SOLID PHASE	8.7E+02	3.0E-02	8.7E+02	3.0E-02	g.kg(d) ⁻¹
Solid species (S)	2.1E-09	5.9E-18	2.1E-09	5.9E-18	g.kg(w) ⁻¹
Species attached to NCs (<450 nm) (A)	8.7E-02	2.4E-10	8.7E-02	2.4E-10	g.kg(w) ⁻¹
Species attached to suspended particles (>450 nm) (P)	1.3E-03	3.5E-12	1.3E-03	3.5E-12	g.kg(w) ⁻¹
Fresh water	1.6E+06	5.1E-06	1.6E+06	5.1E-06	g.L ⁻¹
Dissolved/Gas species (G/D)	1.6E+06	5.1E-06	1.6E+06	5.1E-06	g.L ⁻¹
* DISSOLVED	1.6E+06	5.1E-06	1.6E+06	5.1E-06	g.L ⁻¹
* SUSPENDED SOLIDS	2.7E+03	5.1E-04	2.7E+03	5.1E-04	g.kg(d) ⁻¹
Solid species (S)	7.4E-02	2.4E-13	7.4E-02	2.4E-13	g.L ⁻¹
Species attached to	2.9E+03	9.3E-09	2.9E+03	9.3E-09	g.L ⁻¹

NCs (<450 nm) (A)					
Species attached to suspended particles (>450 nm) (P)	4.4E-01	1.4E-12	4.4E-01	1.4E-12	g.L ⁻¹
Fresh water sediment	6.2E+05	1.6E-04	6.2E+05	1.6E-04	g.kg(w) ⁻¹
Dissolved/Gas species (G/D)	6.2E+05	1.6E-04	6.2E+05	1.6E-04	g.kg(w) ⁻¹
* PORE WATER	5.0E+05	7.9E-03	5.0E+05	7.9E-03	g.L ⁻¹
* SOLID PHASE	1.2E+05	3.9E-01	1.2E+05	3.9E-01	g.kg(d) ⁻¹
Solid species (S)	5.7E-07	1.4E-16	5.7E-07	1.4E-16	g.kg(w) ⁻¹
Species attached to NCs (<450 nm) (A)	6.9E+01	1.7E-08	6.9E+01	1.7E-08	g.kg(w) ⁻¹
Species attached to suspended particles (>450 nm) (P)	4.2E+00	1.1E-09	4.2E+00	1.1E-09	g.kg(w) ⁻¹
Surface sea/ocean water	3.4E+11	4.9E-04	3.4E+11	4.9E-04	g.L ⁻¹
Dissolved/Gas species (G/D)	3.4E+11	4.9E-04	3.4E+11	4.9E-04	g.L ⁻¹
* DISSOLVED	3.4E+11	4.9E-04	3.4E+11	4.9E-04	g.L ⁻¹
* SUSPENDED SOLIDS	2.5E+08	4.9E-02	2.5E+08	4.9E-02	g.kg(d) ⁻¹
Solid species (S)	1.9E+00	2.8E-15	1.9E+00	2.8E-15	g.L ⁻¹
Species attached to NCs (<450 nm) (A)	4.5E+04	6.5E-11	4.5E+04	6.5E-11	g.L ⁻¹
Species attached to suspended particles (>450 nm) (P)	7.5E+01	1.1E-13	7.5E+01	1.1E-13	g.L ⁻¹
Marine sediment	1.8E+09	1.3E-02	1.8E+09	1.3E-02	g.kg(w) ⁻¹
Dissolved/Gas species (G/D)	1.8E+09	1.3E-02	1.8E+09	1.3E-02	g.kg(w) ⁻¹
* PORE WATER	1.5E+09	6.8E-04	1.5E+09	6.8E-04	g.L ⁻¹
* SOLID PHASE	3.7E+08	3.4E-02	3.7E+08	3.4E-02	g.kg(d) ⁻¹
Solid species (S)	9.6E-08	7.1E-19	9.6E-08	7.1E-19	g.kg(w) ⁻¹
Species attached to NCs (<450 nm) (A)	1.7E+01	1.2E-10	1.7E+01	1.2E-10	g.kg(w) ⁻¹
Species attached to suspended particles (>450 nm) (P)	1.1E+01	8.1E-11	1.1E+01	8.1E-11	g.kg(w) ⁻¹
Natural soil	6.3E+06	7.4E-05	6.3E+06	7.4E-05	g.kg(w) ⁻¹
Dissolved/Gas species (G/D)	6.3E+06	7.4E-05	6.3E+06	7.4E-05	g.kg(w) ⁻¹
* PORE WATER	4.2E+04	4.2E-06	4.2E+04	4.2E-06	g.L ⁻¹
* SOLID PHASE	6.3E+06	8.3E-05	6.3E+06	8.3E-05	g.kg(d) ⁻¹
Solid species (S)	1.0E-02	1.2E-13	1.0E-02	1.2E-13	g.kg(w) ⁻¹
Species attached to NCs (<450 nm) (A)	8.2E+03	9.7E-08	8.2E+03	9.7E-08	g.kg(w) ⁻¹
Species attached to suspended particles	5.4E+01	6.3E-10	5.4E+01	6.3E-10	g.kg(w) ⁻¹

(>450 nm) (P)					
Agricultural soil	3.1E+07	4.1E-05	3.1E+07	4.1E-05	g.kg(w) ⁻¹
Dissolved/Gas species (G/D)	3.1E+07	4.1E-05	3.1E+07	4.1E-05	g.kg(w) ⁻¹
* PORE WATER	2.1E+05	2.3E-06	2.1E+05	2.3E-06	g.L ⁻¹
* SOLID PHASE	3.1E+07	4.7E-05	3.1E+07	4.7E-05	g.kg(d) ⁻¹
Solid species (S)	2.2E-02	2.9E-14	2.2E-02	2.9E-14	g.kg(w) ⁻¹
Species attached to NCs (<450 nm) (A)	2.0E+04	2.6E-08	2.0E+04	2.6E-08	g.kg(w) ⁻¹
Species attached to suspended particles (>450 nm) (P)	1.2E+02	1.6E-10	1.2E+02	1.6E-10	g.kg(w) ⁻¹
Other soil	2.3E+06	7.4E-05	2.3E+06	7.4E-05	g.kg(w) ⁻¹
Dissolved/Gas species (G/D)	2.3E+06	7.4E-05	2.3E+06	7.4E-05	g.kg(w) ⁻¹
* PORE WATER	1.5E+04	4.2E-06	1.5E+04	4.2E-06	g.L ⁻¹
* SOLID PHASE	2.3E+06	8.3E-05	2.3E+06	8.3E-05	g.kg(d) ⁻¹
Solid species (S)	3.7E-03	1.2E-13	3.7E-03	1.2E-13	g.kg(w) ⁻¹
Species attached to NCs (<450 nm) (A)	3.1E+03	9.7E-08	3.1E+03	9.7E-08	g.kg(w) ⁻¹
Species attached to suspended particles (>450 nm) (P)	2.0E+01	6.3E-10	2.0E+01	6.3E-10	g.kg(w) ⁻¹
Total D	3.4E+11	4.4E-05	3.4E+11	4.4E-05	g.L ⁻¹
Total S	1.8E+03	2.3E-13	1.8E+03	2.3E-13	g.L ⁻¹
Total A	2.3E+05	2.9E-11	2.3E+05	2.9E-11	g.L ⁻¹
Total P	2.8E+02	3.6E-14	2.8E+02	3.6E-14	g.L ⁻¹
Total	3.4E+11	4.4E-05	3.4E+11	4.4E-05	g.L ⁻¹

34 Table S3. Comparison of steady-state mass and concentration calculations for nZnO, using SimpleBox4nano (v4.01-nano)
 35 in Excel and the SimpleBox4nano web application under default scenarios within the moderate zone (all values are
 36 rounded to one decimal point).

nZnO					
Receiving Compartment	SimpleBox4nano (v4.01-nano) in Excel		SimpleBox4nano		Concentration Units
	Masses (kg)	Concentrations	Masses (kg)	Concentrations	
Air	9.2E+04	1.2E-09	9.2E+04	1.2E-09	g.m ⁻³
Dissolved/Gas species (G/D)	3.0E+03	3.9E-11	3.0E+03	3.9E-11	g.m ⁻³
* GAS PHASE	1.3E-09	1.7E-23	1.3E-09	1.7E-23	g.m ⁻³
* AEROSOL- and CLOUD PHASES	3.0E+03	3.9E-11	3.0E+03	3.9E-11	g.m ⁻³
Solid species (S)	6.6E+01	8.5E-13	6.6E+01	8.5E-13	g.m ⁻³
Species attached to NCs (<450 nm) (A)	8.9E+04	1.1E-09	8.9E+04	1.1E-09	g.m ⁻³
Species attached to suspended particles (>450 nm) (P)	3.6E-03	4.6E-17	3.6E-03	4.6E-17	g.m ⁻³
Surface sea/ocean water	1.9E+12	4.9E-04	1.9E+12	4.9E-04	g.L ⁻¹
Dissolved/Gas species (G/D)	1.9E+12	4.9E-04	1.9E+12	4.9E-04	g.L ⁻¹
* DISSOLVED	1.9E+12	4.9E-04	1.9E+12	4.9E-04	g.L ⁻¹
* SUSPENDED SOLIDS	1.4E+09	4.9E-02	1.4E+09	4.9E-02	g.kg(d) ⁻¹
Solid species (S)	5.9E-02	1.5E-17	5.9E-02	1.5E-17	g.L ⁻¹
Species attached to NCs (<450 nm) (A)	4.0E+04	1.0E-11	4.0E+04	1.0E-11	g.L ⁻¹
Species attached to suspended particles (>450 nm) (P)	1.7E+00	4.5E-16	1.7E+00	4.5E-16	g.L ⁻¹
Deep sea/ocean water	5.7E+13	4.9E-04	5.7E+13	4.9E-04	g.L ⁻¹
Dissolved/Gas species (G/D)	5.7E+13	4.9E-04	5.7E+13	4.9E-04	g.L ⁻¹
* DISSOLVED	5.7E+13	4.9E-04	5.7E+13	4.9E-04	g.L ⁻¹
* SUSPENDED SOLIDS	4.1E+10	4.9E-02	4.1E+10	4.9E-02	g.kg(d) ⁻¹
Solid species (S)	1.7E-05	1.4E-22	1.7E-05	1.4E-22	g.L ⁻¹
Species attached to NCs (<450 nm) (A)	6.0E+03	5.2E-14	6.0E+03	5.2E-14	g.L ⁻¹
Species attached to suspended particles (>450 nm) (P)	5.6E-01	4.8E-18	5.6E-01	4.8E-18	g.L ⁻¹
Marine sediment	2.0E+10	1.3E-02	2.0E+10	1.3E-02	g.kg(w) ⁻¹
Dissolved/Gas species (G/D)	2.0E+10	1.3E-02	2.0E+10	1.3E-02	g.kg(w) ⁻¹
* PORE WATER	1.6E+10	6.8E-04	1.6E+10	6.8E-04	g.L ⁻¹
* SOLID PHASE	4.1E+09	3.4E-02	4.1E+09	3.4E-02	g.kg(d) ⁻¹
Solid species (S)	5.6E-14	3.7E-26	5.6E-14	3.7E-26	g.kg(w) ⁻¹

Species attached to NCs (<450 nm) (A)	1.5E-01	9.7E-14	1.5E-01	9.7E-14	g.kg(w) ⁻¹
Species attached to suspended particles (>450 nm) (P)	5.5E-03	3.6E-15	5.5E-03	3.6E-15	g.kg(w) ⁻¹
Other soil	1.3E+07	4.0E-06	1.3E+07	4.0E-06	g.kg(w) ⁻¹
Dissolved/Gas species (G/D)	1.3E+07	4.0E-06	1.3E+07	4.0E-06	g.kg(w) ⁻¹
* PORE WATER	8.7E+04	2.2E-07	8.7E+04	2.2E-07	g.L ⁻¹
* SOLID PHASE	1.3E+07	4.5E-06	1.3E+07	4.5E-06	g.kg(d) ⁻¹
Solid species (S)	3.6E-03	1.1E-15	3.6E-03	1.1E-15	g.kg(w) ⁻¹
Species attached to NCs (<450 nm) (A)	5.0E+04	1.5E-08	5.0E+04	1.5E-08	g.kg(w) ⁻¹
Species attached to suspended particles (>450 nm) (P)	2.0E+01	5.9E-12	2.0E+01	5.9E-12	g.kg(w) ⁻¹
Total D	5.9E+13	3.0E-04	5.9E+13	3.0E-04	g.L ⁻¹
Total S	6.6E+01	3.3E-16	6.6E+01	3.3E-16	g.L ⁻¹
Total A	1.8E+05	9.3E-13	1.8E+05	9.3E-13	g.L ⁻¹
Total P	2.2E+01	1.1E-16	2.2E+01	1.1E-16	g.L ⁻¹
Total	5.9E+13	3.0E-04	5.9E+13	3.0E-04	g.L ⁻¹

37

38 Table S4. Comparison of steady-state mass and concentration calculations for nZnO, using SimpleBox4nano (v4.01-nano)
 39 in Excel and the SimpleBox4nano web application under default scenarios within the arctic zone (all values are rounded
 40 to one decimal point).

nZnO					
Receiving Compartment	SimpleBox4Nano (v4.01-nano) in Excel		SimpleBox4Nano		Concentration Units
	Masses (kg)	Concentrations	Masses (kg)	Concentrations	
Air	1.9E+04	4.5E-10	1.9E+04	4.5E-10	g.m ⁻³
Dissolved/Gas species (G/D)	1.3E+02	3.1E-12	1.3E+02	3.1E-12	g.m ⁻³
* GAS PHASE	5.6E-11	1.3E-24	5.6E-11	1.3E-24	g.m ⁻³
* AEROSOL- and CLOUD PHASES	1.3E+02	3.1E-12	1.3E+02	3.1E-12	g.m ⁻³
Solid species (S)	7.3E-01	1.7E-14	7.3E-01	1.7E-14	g.m ⁻³
Species attached to NCs (<450 nm) (A)	1.9E+04	4.5E-10	1.9E+04	4.5E-10	g.m ⁻³
Species attached to suspended particles (>450 nm) (P)	1.1E-04	2.5E-18	1.1E-04	2.5E-18	g.m ⁻³
Surface sea/ocean water	1.5E+12	6.0E-04	1.5E+12	6.0E-04	g.L ⁻¹
Dissolved/Gas species (G/D)	1.5E+12	6.0E-04	1.5E+12	6.0E-04	g.L ⁻¹
* DISSOLVED	1.5E+12	6.0E-04	1.5E+12	6.0E-04	g.L ⁻¹
* SUSPENDED SOLIDS	1.1E+09	6.0E-02	1.1E+09	6.0E-02	g.kg(d) ⁻¹
Solid species (S)	6.6E-04	2.6E-19	6.6E-04	2.6E-19	g.L ⁻¹
Species attached to NCs (<450 nm) (A)	8.2E+03	3.2E-12	8.2E+03	3.2E-12	g.L ⁻¹
Species attached to suspended particles (>450 nm) (P)	3.8E-02	1.5E-17	3.8E-02	1.5E-17	g.L ⁻¹
Deep sea/ocean water	3.8E+13	4.9E-04	3.8E+13	4.9E-04	g.L ⁻¹
Dissolved/Gas species (G/D)	3.8E+13	4.9E-04	3.8E+13	4.9E-04	g.L ⁻¹
* DISSOLVED	3.8E+13	4.9E-04	3.8E+13	4.9E-04	g.L ⁻¹
* SUSPENDED SOLIDS	2.7E+10	4.9E-02	2.7E+10	4.9E-02	g.kg(d) ⁻¹
Solid species (S)	2.2E-07	2.9E-24	2.2E-07	2.9E-24	g.L ⁻¹
Species attached to NCs (<450 nm) (A)	1.3E+03	1.7E-14	1.3E+03	1.7E-14	g.L ⁻¹
Species attached to suspended particles (>450 nm) (P)	1.3E-02	1.7E-19	1.3E-02	1.7E-19	g.L ⁻¹
Marine sediment	1.3E+10	1.3E-02	1.3E+10	1.3E-02	g.kg(w) ⁻¹
Dissolved/Gas species (G/D)	1.3E+10	1.3E-02	1.3E+10	1.3E-02	g.kg(w) ⁻¹
* PORE WATER	1.1E+10	6.8E-04	1.1E+10	6.8E-04	g.L ⁻¹
* SOLID PHASE	2.7E+09	3.4E-02	2.7E+09	3.4E-02	g.kg(d) ⁻¹
Solid species (S)	7.4E-16	7.4E-28	7.4E-16	7.4E-28	g.kg(w) ⁻¹

Species attached to NCs (<450 nm) (A)	3.3E-02	3.3E-14	3.3E-02	3.3E-14	g.kg(w) ⁻¹
Species attached to suspended particles (>450 nm) (P)	1.2E-04	1.2E-16	1.2E-04	1.3E-16	g.kg(w) ⁻¹
Other soil	3.8E+06	2.6E-06	3.8E+06	2.6E-06	g.kg(w) ⁻¹
Dissolved/Gas species (G/D)	3.8E+06	2.6E-06	3.8E+06	2.6E-06	g.kg(w) ⁻¹
* PORE WATER	2.5E+04	1.5E-07	2.5E+04	1.5E-07	g.L ⁻¹
* SOLID PHASE	3.8E+06	3.0E-06	3.8E+06	3.0E-06	g.kg(d) ⁻¹
Solid species (S)	2.2E-05	1.5E-17	2.2E-05	1.5E-17	g.kg(w) ⁻¹
Species attached to NCs (<450 nm) (A)	6.1E+03	4.2E-09	6.1E+03	4.2E-09	g.kg(w) ⁻¹
Species attached to suspended particles (>450 nm) (P)	1.2E-01	8.1E-14	1.2E-01	8.1E-14	g.kg(w) ⁻¹
Total D	3.9E+13	3.2E-04	3.9E+13	3.2E-04	g.L ⁻¹
Total S	7.3E-01	6.0E-18	7.3E-01	6.0E-18	g.L ⁻¹
Total A	3.5E+04	2.9E-13	3.5E+04	2.9E-13	g.L ⁻¹
Total P	1.7E-01	1.4E-18	1.7E-01	1.4E-18	g.L ⁻¹
Total	3.9E+13	3.2E-04	3.9E+13	3.2E-04	g.L ⁻¹

41

42 Table S5. Comparison of steady-state mass and concentration calculations for nZnO, using SimpleBox4nano (v4.01-nano)
 43 in Excel and the SimpleBox4nano web application under default scenarios within the tropic zone (all values are rounded
 44 to one decimal point).

nZnO					
	SimpleBox4nano (v4.01-nano) in Excel		SimpleBox4nano		
Receiving Compartment	Masses (kg)	Concentrations	Masses (kg)	Concentrations	Concentration Units
Air	2.7E+04	2.1E-10	2.7E+04	2.1E-10	g.m ⁻³
Dissolved/Gas species (G/D)	2.3E+02	1.8E-12	2.3E+02	1.8E-12	g.m ⁻³
* GAS PHASE	9.9E-11	3.1E-24	9.9E-11	3.1E-24	g.m ⁻³
* AEROSOL- and CLOUD PHASES	2.3E+02	1.8E-12	2.3E+02	1.8E-12	g.m ⁻³
Solid species (S)	1.1E+00	8.7E-15	1.1E+00	8.7E-15	g.m ⁻³
Species attached to NCs (<450 nm) (A)	2.6E+04	2.1E-10	2.6E+04	2.1E-10	g.m ⁻³
Species attached to suspended particles (>450 nm) (P)	3.7E-05	2.9E-19	3.7E-05	2.9E-19	g.m ⁻³
Surface sea/ocean water	4.4E+12	4.9E-04	4.4E+12	4.9E-04	g.L ⁻¹
Dissolved/Gas species (G/D)	4.4E+12	4.9E-04	4.4E+12	4.9E-04	g.L ⁻¹
* DISSOLVED	4.4E+12	4.9E-04	4.4E+12	4.9E-04	g.L ⁻¹
* SUSPENDED SOLIDS	3.2E+09	4.9E-02	3.2E+09	4.9E-02	g.kg(d) ⁻¹
Solid species (S)	1.6E-03	1.8E-19	1.6E-03	1.8E-19	g.L ⁻¹
Species attached to NCs (<450 nm) (A)	1.9E+04	2.2E-12	1.9E+04	2.2E-12	g.L ⁻¹
Species attached to suspended particles (>450 nm) (P)	1.8E-02	2.1E-18	1.8E-02	2.1E-18	g.L ⁻¹
Deep sea/ocean water	1.4E+14	5.3E-04	1.4E+14	5.3E-04	g.L ⁻¹
Dissolved/Gas species (G/D)	1.4E+14	5.3E-04	1.4E+14	5.3E-04	g.L ⁻¹
* DISSOLVED	1.4E+14	5.3E-04	1.4E+14	5.3E-04	g.L ⁻¹
* SUSPENDED SOLIDS	1.0E+11	5.3E-02	1.0E+11	5.3E-02	g.kg(d) ⁻¹
Solid species (S)	4.0E-07	1.5E-24	4.0E-07	1.5E-24	g.L ⁻¹
Species attached to NCs (<450 nm) (A)	2.7E+03	1.0E-14	2.7E+03	1.0E-14	g.L ⁻¹
Species attached to suspended particles (>450 nm) (P)	6.2E-03	2.3E-20	6.2E-03	2.3E-20	g.L ⁻¹
Marine sediment	5.0E+10	1.4E-02	5.0E+10	1.4E-02	g.kg(w) ⁻¹
Dissolved/Gas species (G/D)	5.0E+10	1.4E-02	5.0E+10	1.4E-02	g.kg(w) ⁻¹
* PORE WATER	4.0E+10	7.3E-04	4.0E+10	7.3E-04	g.L ⁻¹
* SOLID PHASE	1.0E+10	3.6E-02	1.0E+10	3.6E-02	g.kg(d) ⁻¹
Solid species (S)	1.3E-15	3.7E-28	1.3E-15	3.7E-28	g.kg(w) ⁻¹

Species attached to NCs (<450 nm) (A)	6.5E-02	1.9E-14	6.5E-02	1.9E-14	g.kg(w) ⁻¹
Species attached to suspended particles (>450 nm) (P)	6.0E-05	1.7E-17	6.0E-05	1.7E-17	g.kg(w) ⁻¹
Other soil	1.3E+06	3.9E-07	1.3E+06	3.9E-07	g.kg(w) ⁻¹
Dissolved/Gas species (G/D)	1.3E+06	3.9E-07	1.3E+06	3.9E-07	g.kg(w) ⁻¹
* PORE WATER	8.4E+03	2.2E-08	8.4E+03	2.2E-08	g.L ⁻¹
* SOLID PHASE	1.3E+06	4.4E-07	1.3E+06	4.4E-07	g.kg(d) ⁻¹
Solid species (S)	4.7E-05	1.4E-17	4.7E-05	1.4E-17	g.kg(w) ⁻¹
Species attached to NCs (<450 nm) (A)	1.0E+04	3.2E-09	1.0E+04	3.2E-09	g.kg(w) ⁻¹
Species attached to suspended particles (>450 nm) (P)	2.5E-01	7.8E-14	2.5E-01	7.8E-14	g.kg(w) ⁻¹
Total D	1.5E+14	3.6E-04	1.5E+14	3.6E-04	g.L ⁻¹
Total S	1.1E+00	2.8E-18	1.1E+00	2.8E-18	g.L ⁻¹
Total A	5.9E+04	1.5E-13	5.9E+04	1.5E-13	g.L ⁻¹
Total P	2.8E-01	6.9E-19	2.8E-01	6.9E-19	g.L ⁻¹
Total	1.5E+14	3.6E-04	1.5E+14	3.6E-04	g.L ⁻¹

45

46 S2. Comparison of steady-state mass flow (kg s⁻¹) calculations using SimpleBox4nano (v4.01-nano) in Excel and the *SimpleBox4nano* web application

47

48 Table S6. Steady-state mass flows (kg s⁻¹) calculations for nZnO, using SimpleBox4nano (v4.01-nano) in Excel under default scenarios (all values are rounded to one decimal point).

Dissolved species		Emission	Inflow	Outflow	Removal	Formation (S,A,P->D)	Degradation	air-water transport	water-air transport	air-soil transport	soil-air transport	soil-water transport	water-sed transport	sed-water transport	mass balance
Regional Scale															
air	aR	3.2E-01	5.9E-03	1.9E-01	7.3E-06		7.6E-29	1.4E-01	2.0E-18						0.0E+00
fresh water lakes	w0R		0.0E+00	4.3E-04		9.2E-05	7.3E-17	3.4E-04	9.0E-24				1.4E-06	0.0E+00	0.0E+00
fresh water	w1R	3.2E-01	4.3E-04	1.4E+00		2.6E-01	7.7E-14	3.7E-03	3.2E-19			7.7E-01	4.9E-01	5.2E-01	0.0E+00
coastal sea water	w2R	0.0E+00	7.4E+00	7.4E+00		6.3E-03	2.2E-14	5.9E-04	2.7E-20				2.6E-02	2.6E-02	0.0E+00
fresh water sediment	sd1R				2.4E-02	5.4E-02	3.4E-14						4.9E-01	5.2E-01	0.0E+00
coastal marine sediment	sd2R				5.4E-04	2.2E-04	2.4E-15						2.6E-02	2.6E-02	0.0E+00
natural soil	s1R	0.0E+00			2.7E-04	4.0E-03	3.5E-14			3.7E-02	8.6E-20	4.0E-02			0.0E+00
agricultural soil	s2R	3.2E-01			4.8E-03	3.2E-01	1.3E-12			8.1E-02	1.5E-18	7.1E-01			0.0E+00
other soil	s3R	0.0E+00			1.0E-04	1.5E-03	1.3E-14			1.4E-02	3.2E-20	1.5E-02			0.0E+00
Continental Scale															
air	aC	0.0E+00	1.9E-01	3.3E-02	7.2E-06		7.5E-29	1.5E-01	8.7E-17						0.0E+00
fresh water lakes	w0C		0.0E+00	3.8E-04		1.9E-04	6.4E-16	2.0E-04	8.0E-23				1.2E-05	0.0E+00	0.0E+00
fresh water	w1C	0.0E+00	3.8E-04	1.1E-01		4.7E-03	6.3E-15	2.2E-03	2.6E-20			1.1E-01	4.0E-02	3.8E-02	0.0E+00
coastal sea water	w2C	0.0E+00	1.1E+04	1.1E+04		7.5E-02	1.4E-09	7.5E-02	8.6E-17				8.3E+01	8.1E+01	0.0E+00
fresh water sediment	sd1C				1.8E-03	7.3E-05	2.5E-15						4.0E-02	3.8E-02	0.0E+00
coastal marine sediment	sd2C				1.7E+00	2.8E-05	7.4E-12						8.3E+01	8.1E+01	0.0E+00
natural soil	s1C	0.0E+00			2.0E-04	8.3E-03	2.6E-14			2.1E-02	6.3E-20	3.0E-02			0.0E+00
agricultural soil	s2C	0.0E+00			4.5E-04	2.0E-02	1.3E-13			4.8E-02	1.4E-19	6.7E-02			0.0E+00
other soil	s3C	0.0E+00			7.3E-05	3.1E-03	9.5E-15			7.9E-03	2.3E-20	1.1E-02			0.0E+00
Global Scale - Moderate climate zone															
air	aM	0.0E+00	2.7E-02	3.5E-03	1.1E-06		1.2E-29	2.4E-02	9.6E-16						0.0E+00
upper ocean water	w2M	0.0E+00	5.6E+05	5.6E+05		6.6E-02	7.7E-09	1.2E-02	9.6E-16			6.1E-02			0.0E+00
deep sea	w3M		5.5E+05	5.5E+05		9.9E-03	2.3E-07						9.2E+02	9.2E+02	0.0E+00
ocean sediment	sdM				6.1E-02	1.5E-07	8.3E-11						9.2E+02	9.2E+02	0.0E+00
soil	sM	0.0E+00			4.1E-04	5.0E-02	5.3E-14			1.2E-02	1.3E-19	6.1E-02			0.0E+00
Global Scale - Arctic climate zone															
air	aA	0.0E+00	1.1E-03	9.1E-05	4.8E-08		4.2E-31	1.1E-03	1.7E-21						0.0E+00
upper ocean water	w2A	0.0E+00	4.1E+05	4.1E+05		1.3E-02	1.3E-09	6.3E-04	1.7E-21			6.5E-03			0.0E+00
deep sea	w3A		4.1E+05	4.1E+05		2.2E-03	3.3E-08						6.1E+02	6.1E+02	0.0E+00
ocean sediment	sdA				2.8E-02	3.3E-08	1.2E-11						6.1E+02	6.1E+02	0.0E+00
soil	sA	0.0E+00			4.3E-05	6.1E-03	3.4E-15			4.2E-04	8.5E-26	6.5E-03			0.0E+00
Global Scale - Tropical climate zone															
air	aT	0.0E+00	2.0E-03	9.4E-05	8.6E-08		3.9E-30	1.9E-03	2.0E-12						0.0E+00
upper ocean water	w2T	0.0E+00	1.1E+06	1.1E+06		3.2E-02	4.4E-08	1.3E-03	2.0E-12			1.1E-02			0.0E+00
deep sea	w3T		1.1E+06	1.1E+06		4.4E-03	1.4E-06						2.3E+03	2.3E+03	0.0E+00
ocean sediment	sdT				1.1E-01	6.5E-08	5.0E-10						2.3E+03	2.3E+03	0.0E+00
soil	sT	0.0E+00			7.4E-05	1.0E-02	1.3E-14			5.7E-04	1.1E-17	1.1E-02			0.0E+00
		9.5E-01			1.9E+00		1.7E-06								0.0E+00

49

50 Table S7. Steady-state mass flows (kg s⁻¹) calculations for nZnO, using SimpleBox4nano web application under default scenarios (all values are rounded to one decimal point).

Dissolved species		Emission	Inflow	Outflow	Removal	Formation (S,A,P->D)	Degradation	air-water transport	water-air transport	air-soil transport	soil-air transport	soil-water transport	water-sed transport	sed-water transport	mass balance
Regional Scale															
air	aR	3.2E-01	5.9E-03	1.9E-01	7.3E-06		1.1E-28	1.4E-01	3.7E-18						0.0E+00
fresh water lakes	w0R		0.0E+00	4.3E-04		9.2E-05	7.3E-17	3.4E-04	2.1E-23				1.4E-06	0.0E+00	0.0E+00
fresh water	w1R	3.2E-01	4.3E-04	1.4E+00		2.6E-01	7.7E-14	3.7E-03	7.5E-19			7.7E-01	4.9E-01	5.2E-01	0.0E+00
coastal sea water	w2R	0.0E+00	7.4E+00	7.4E+00		6.3E-03	2.2E-14	5.9E-04	6.5E-20				2.6E-02	2.6E-02	0.0E+00
fresh water sediment	sd1R				2.4E-02	5.4E-02	3.4E-14						4.9E-01	5.2E-01	0.0E+00
coastal marine sediment	sd2R				5.4E-04	2.2E-04	2.4E-15						2.6E-02	2.6E-02	0.0E+00
natural soil	s1R	0.0E+00			2.7E-04	4.0E-03	3.5E-14			3.7E-02	1.5E-19	4.0E-02			0.0E+00
agricultural soil	s2R	3.2E-01			4.8E-03	3.2E-01	1.4E-12			8.1E-02	2.7E-18	7.1E-01			0.0E+00
other soil	s3R	0.0E+00			1.0E-04	1.5E-03	1.3E-14			1.4E-02	5.7E-20	1.5E-02			0.0E+00
Continental Scale															
air	aC	0.0E+00	1.9E-01	3.3E-02	7.2E-06		1.1E-28	1.5E-01	2.0E-16						0.0E+00
fresh water lakes	w0C		0.0E+00	3.8E-04		1.9E-04	6.4E-16	2.0E-04	1.9E-22				1.2E-05	0.0E+00	0.0E+00
fresh water	w1C	0.0E+00	3.8E-04	1.1E-01		4.7E-03	6.3E-15	2.2E-03	6.2E-20			1.1E-01	4.0E-02	3.8E-02	0.0E+00
coastal sea water	w2C	0.0E+00	1.1E+04	1.1E+04		7.5E-02	1.4E-09	7.5E-02	2.0E-16				8.3E+01	8.1E+01	0.0E+00
fresh water sediment	sd1C				1.8E-03	7.3E-05	2.5E-15						4.0E-02	3.8E-02	0.0E+00
coastal marine sediment	sd2C				1.7E+00	2.8E-05	7.4E-12						8.3E+01	8.1E+01	0.0E+00
natural soil	s1C	0.0E+00			2.0E-04	8.3E-03	2.6E-14			2.1E-02	1.1E-19	3.0E-02			0.0E+00
agricultural soil	s2C	0.0E+00			4.5E-04	2.0E-02	1.3E-13			4.8E-02	2.6E-19	6.7E-02			0.0E+00
other soil	s3C	0.0E+00			7.3E-05	3.1E-03	9.5E-15			7.9E-03	4.2E-20	1.1E-02			0.0E+00
Global Scale - Moderate climate zone															
air	aM	0.0E+00	2.7E-02	3.5E-03	1.1E-06		1.7E-29	2.4E-02	2.3E-15						0.0E+00
upper ocean water	w2M	0.0E+00	5.6E+05	5.6E+05		6.6E-02	7.7E-09	1.2E-02	2.3E-15			6.1E-02			3.7E-06
deep sea	w3M		5.5E+05	5.5E+05		9.9E-03	2.3E-07						9.2E+02	9.2E+02	-3.2E-06
ocean sediment	sdM				6.1E-02	1.5E-07	8.3E-11						9.2E+02	9.2E+02	0.0E+00
soil	sM	0.0E+00			4.1E-04	5.0E-02	5.3E-14			1.2E-02	2.4E-19	6.1E-02			0.0E+00
Global Scale - Arctic climate zone															
air	aA	0.0E+00	1.1E-03	9.1E-05	4.8E-08		6.3E-31	1.1E-03	1.3E-20						0.0E+00
upper ocean water	w2A	0.0E+00	4.1E+05	4.1E+05		1.4E-02	1.4E-09	6.3E-04	1.3E-20			6.5E-03			-5.0E-07
deep sea	w3A		4.1E+05	4.1E+05		2.2E-03	3.3E-08						6.1E+02	6.1E+02	0.0E+00
ocean sediment	sdA				2.8E-02	3.3E-08	1.2E-11						6.1E+02	6.1E+02	0.0E+00
soil	sA	0.0E+00			4.3E-05	6.1E-03	3.4E-15			4.2E-04	4.7E-25	6.5E-03			0.0E+00
Global Scale - Tropical climate zone															
air	aT	0.0E+00	2.0E-03	9.4E-05	8.6E-08		3.9E-30	1.9E-03	2.6E-12						0.0E+00
upper ocean water	w2T	0.0E+00	1.1E+06	1.1E+06		3.2E-02	4.4E-08	1.3E-03	2.6E-12			1.1E-02			0.0E+00
deep sea	w3T		1.1E+06	1.1E+06		4.4E-03	1.4E-06						2.3E+03	2.3E+03	0.0E+00
ocean sediment	sdT				1.1E-01	6.5E-08	5.0E-10						2.3E+03	2.3E+03	0.0E+00
soil	sT	0.0E+00			7.4E-05	1.0E-02	1.3E-14			5.7E-04	1.1E-17	1.1E-02			0.0E+00
		9.5E-01			1.9E+00		1.7E-06								0.0E+00

51

52 **S3. Comparison of dynamic output**

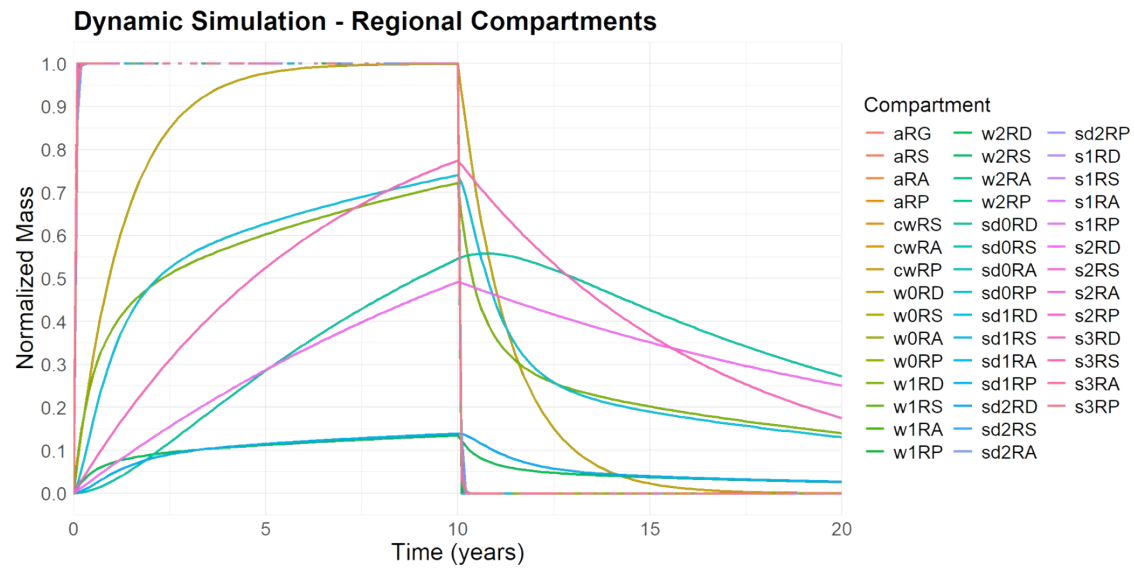

53

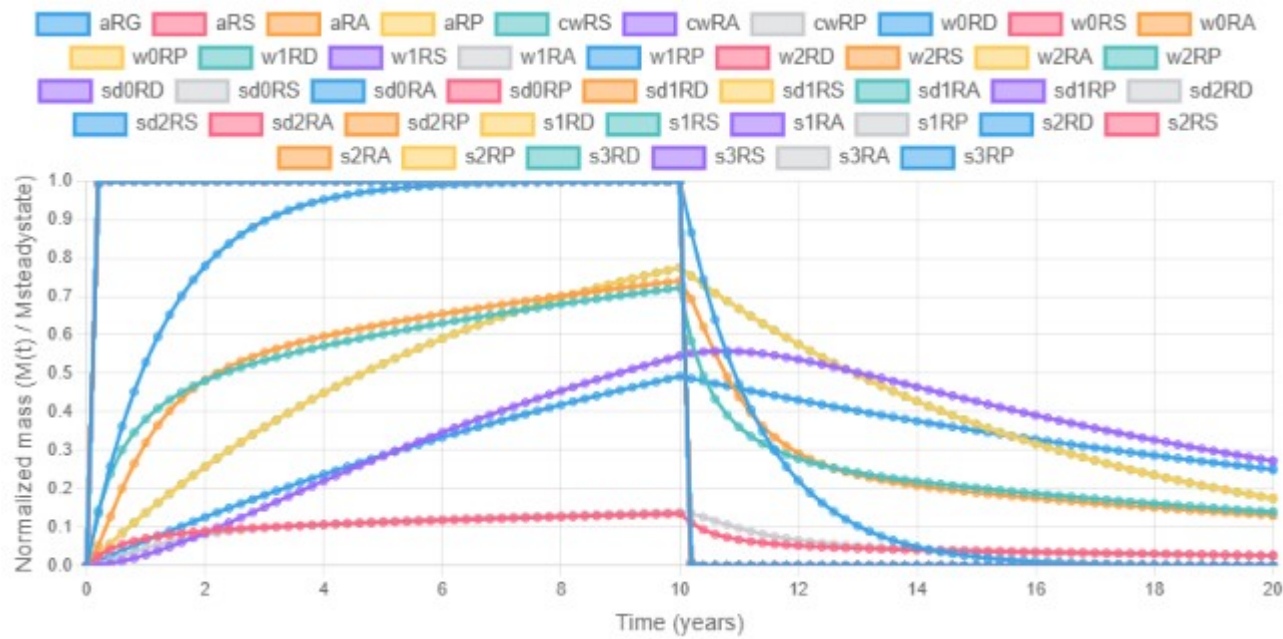

54

55 **Figure S1.** Comparison of dynamic calculations of normalized mass (defined as the ratio of dynamic mass divided by the steady-state mass) over time for nZnO, determined using
 56 the Dynamic Rshell for SimpleBox4nano (v4.01-nano) and the *SimpleBox4nano* web application (bottom panel), under default scenarios within the regional scale.

57

Dynamic Simulation - Continental Compartments

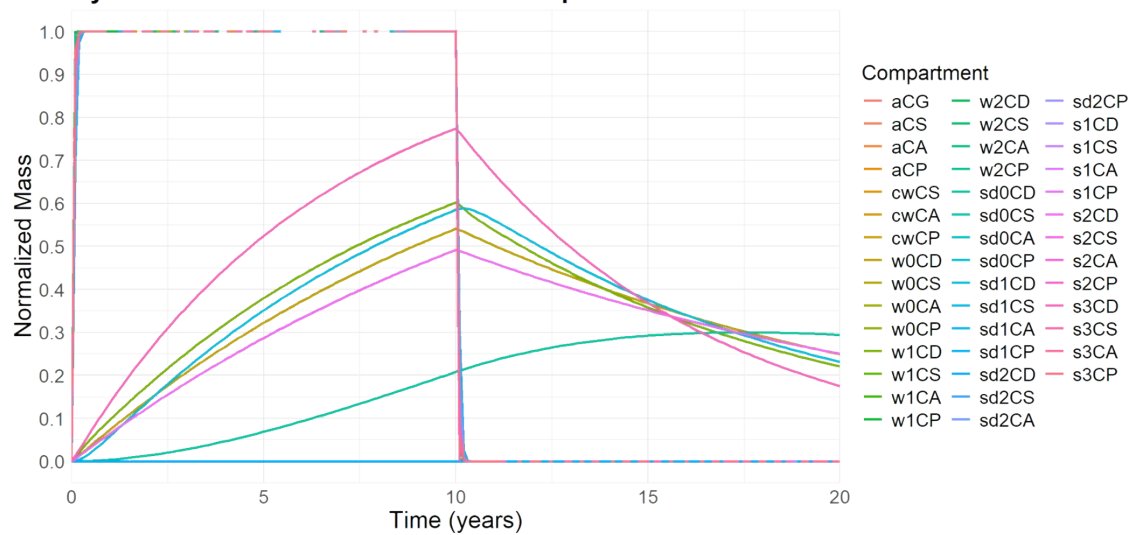

58

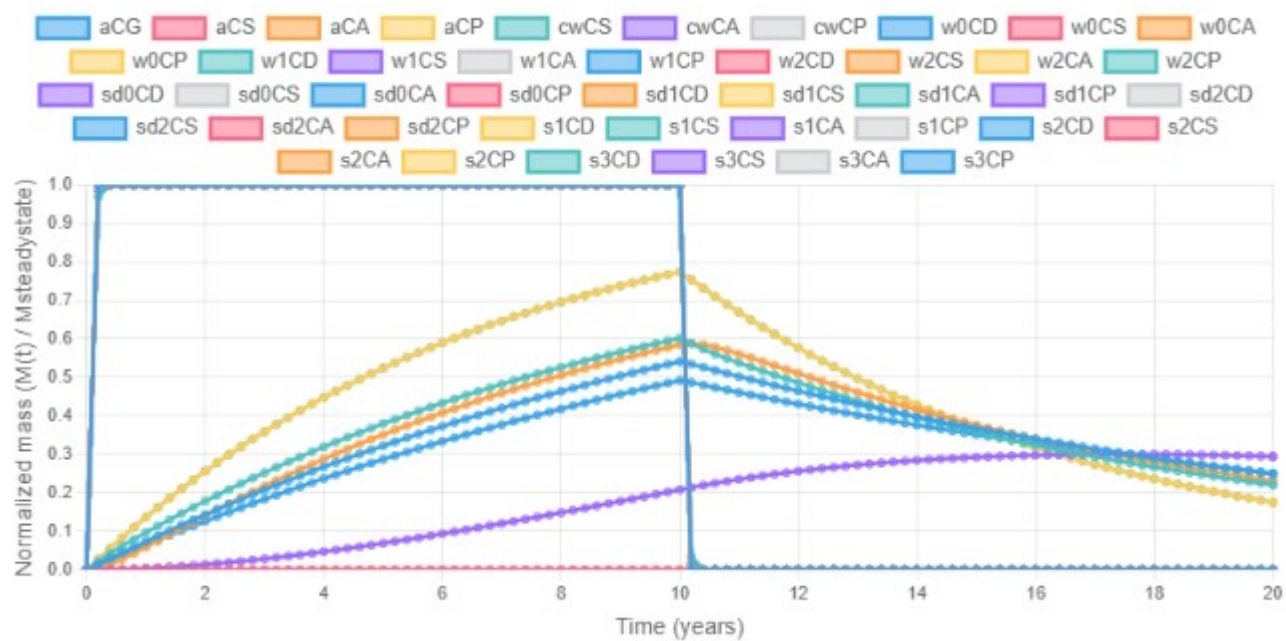

59

60 **Figure S2.** Comparison of dynamic calculations of normalized mass (defined as the ratio of dynamic mass divided by the steady-state mass) over time for nZnO, determined using
 61 the Dynamic Rshell for SimpleBox4nano (v4.01-nano) and the *SimpleBox4nano* web application (bottom panel), under default scenarios within the continental scale.

62

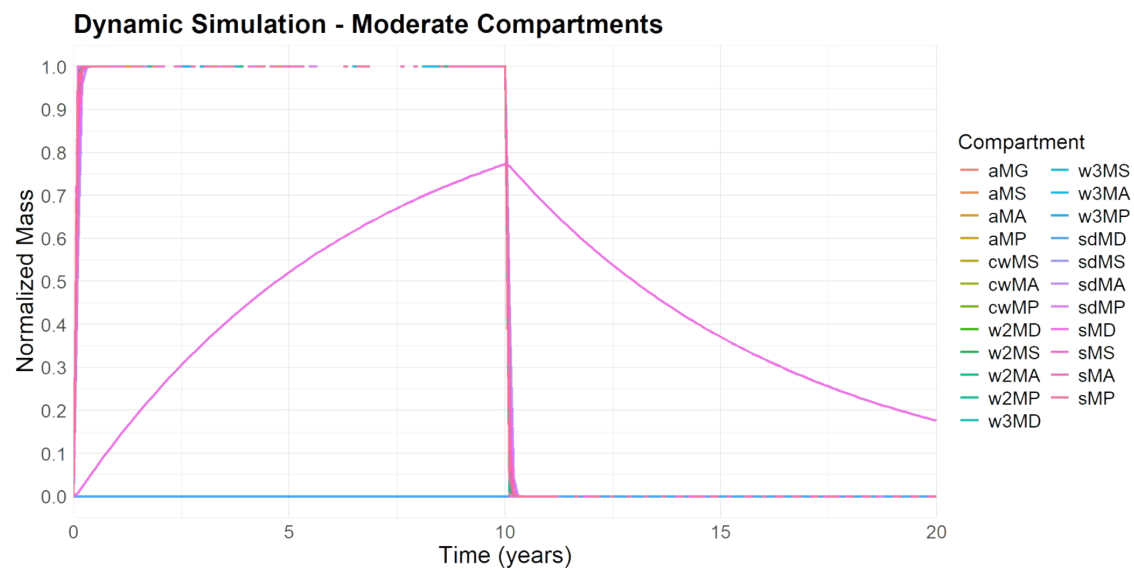

63

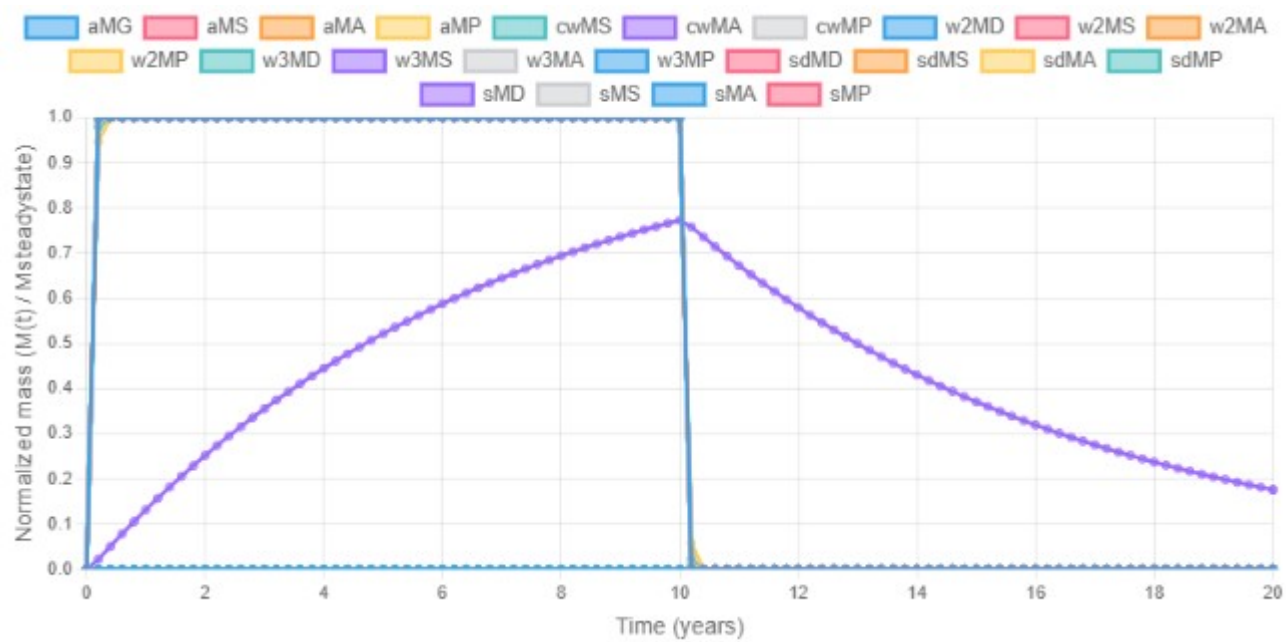

64

65 **Figure S3.** Comparison of dynamic calculations of normalized mass (defined as the ratio of dynamic mass divided by the steady-state mass) over time for nZnO, determined using
 66 the Dynamic Rshell for SimpleBox4nano (v4.01-nano) and the *SimpleBox4nano* web application (bottom panel), under default scenarios within the moderate zone.

67

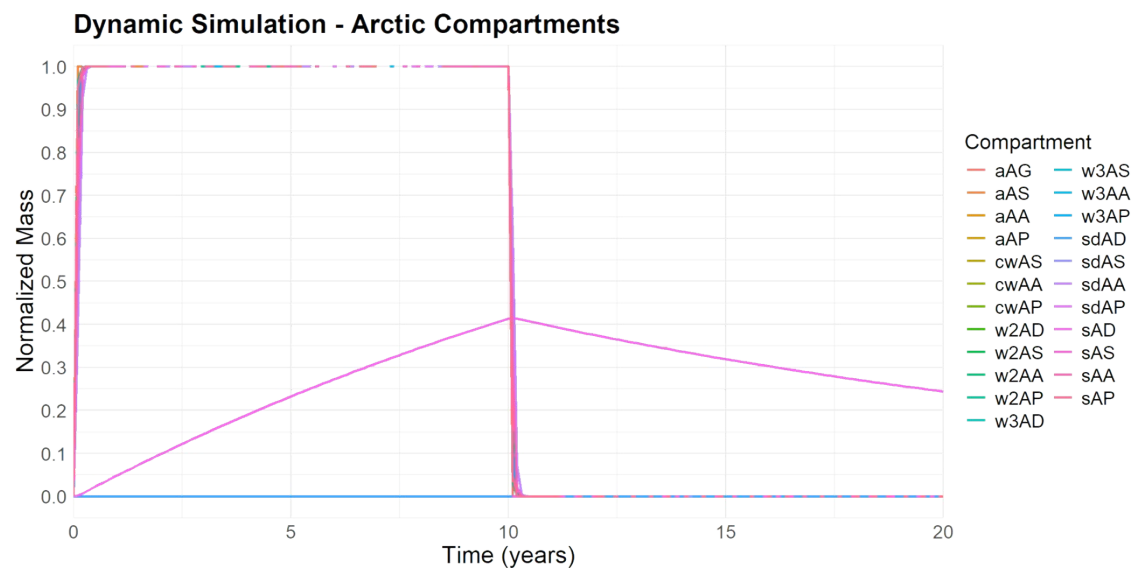

68

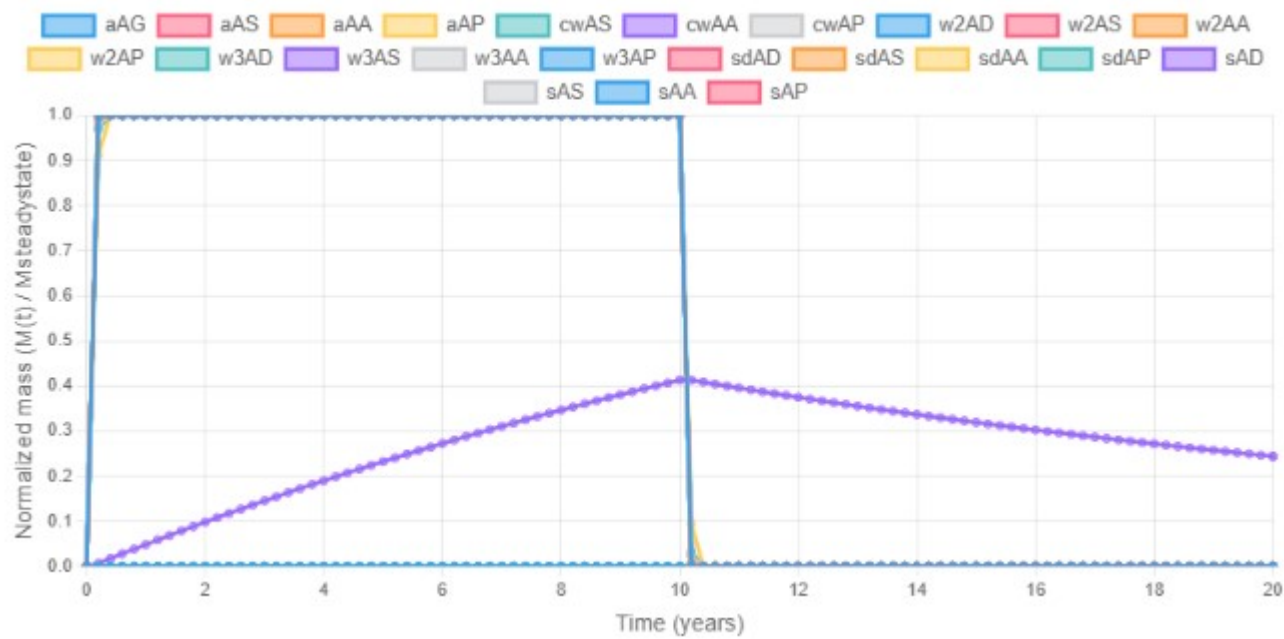

69

70 **Figure S4.** Comparison of dynamic calculations of normalized mass (defined as the ratio of dynamic mass divided by the steady-state mass) over time for nZnO, determined using
 71 the Dynamic Rshell for SimpleBox4nano (v4.01-nano) and the *SimpleBox4nano* web application (bottom panel), under default scenarios within the arctic zone.

72

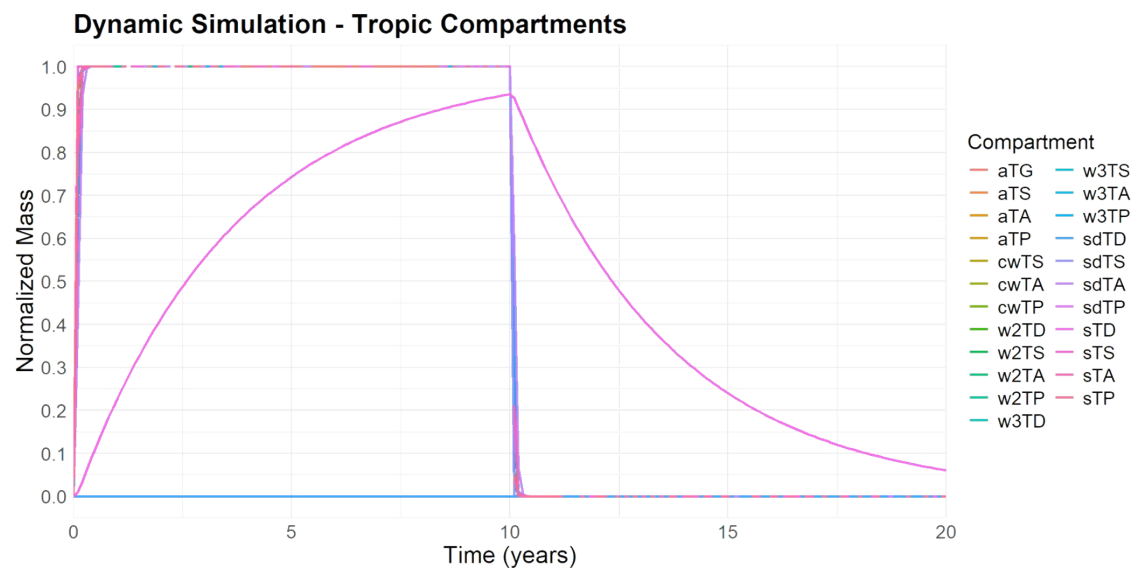

73

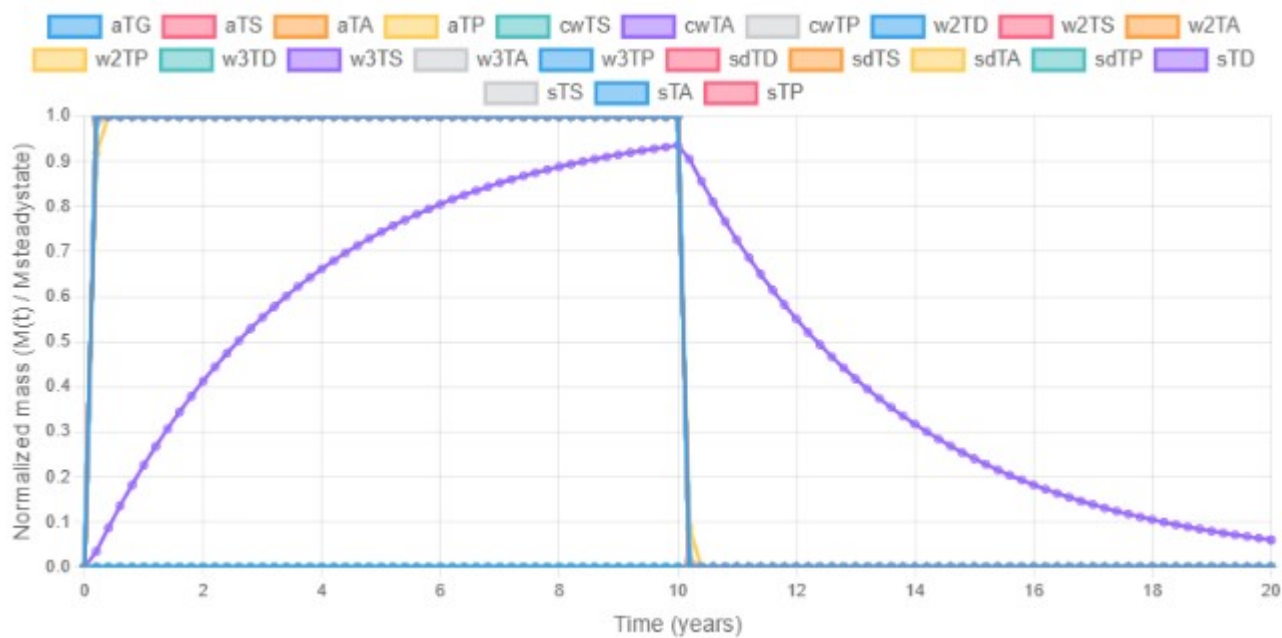

74

75 **Figure S5.** Comparison of dynamic calculations of normalized mass (defined as the ratio of dynamic mass divided by the steady-state mass) over time for nZnO, determined using
 76 the Dynamic Rshell for SimpleBox4nano (v4.01-nano) and the *SimpleBox4nano* web application (bottom panel), under default scenarios within the tropic zone.

77

78 S4. Output window after selecting 'Execute Steady-State Simulation'

Steady-State Simulation Table 1 Table 2 Graphical Output of Scale Zone Compartments

Steady-State Simulation

Objective: To determine the equilibrium distribution of a chemical under constant input conditions.

Mathematical Basis: The system assumes that the inputs (emissions) and outputs (degradation, advection, etc.) are constant, and the net change in mass (i.e., dM/dt) is zero in each compartment.

Key Equation: The steady-state mass balance equation is solved by setting:

$$\frac{dM}{dt} = 0 \Rightarrow \mathbf{K} \cdot \mathbf{M}_{ss} + \mathbf{E} = 0$$

where:

- \mathbf{K} (s^{-1}) is the matrix of transfer rate coefficients between compartments,
- \mathbf{M}_{ss} (kg) is the vector of masses (or fugacities) in compartments at steady-state,
- \mathbf{E} ($kg\ s^{-1}$) is the vector of constant emission rates

The model computes the **steady-state fugacity or mass** in each compartment using algebraic methods such as matrix inversion (e.g., solving $\mathbf{M} = -\mathbf{K}^{-1} \cdot \mathbf{E}$). The result tells you the **long-term average concentrations** assuming emissions are constant.

79

Steady-State Simulation Table 1 Table 2 Graphical Output of Scale Zone Compartments

Download Table 1

	Masses (kg)										Concentrations	
	Reg	Cont	Mod	Arct	Trop	Reg	Cont	Mod	Arct	Trop	Reg	
Air	5.612E+04	0.01 %	1.597E+05	0.00 %	9.148E+04	0.00 %	1.891E+04	4.858E-10	2.791E+04	0.00 %	2.444E-07	2
Dissolved/Gas species (G/D)	1.983E+04	0.01 %	1.975E+04	0.00 %	3.028E+03	0.00 %	1.319E+02	3.388E-12	2.344E+02	0.00 %	8.640E-08	2
* GAS PHASE	2.951E-08	0.00 %	2.939E-08	0.00 %	4.506E-09	0.00 %	1.962E-10	5.040E-24	3.488E-10	0.00 %	1.285E-19	4
* AEROSOL- and CLOUD PHASES	1.983E+04	0.01 %	1.975E+04	0.00 %	3.028E+03	0.00 %	1.319E+02	3.388E-12	2.344E+02	0.00 %	8.640E-08	2
Solid species (S)	1.160E+04	0.00 %	5.394E+03	0.00 %	3.716E+02	0.00 %	7.653E+00	1.966E-13	1.192E+01	0.00 %	5.054E-08	7
Species attached to NCs (<450 nm) (A)	2.468E+04	0.01 %	1.345E+05	0.00 %	8.808E+04	0.00 %	1.877E+04	4.822E-10	2.766E+04	0.00 %	1.075E-07	1
Species attached to suspended particles (>450 nm) (P)	1.117E+00	0.00 %	7.080E-01	0.00 %	5.224E-02	0.00 %	2.726E-03	7.003E-17	9.713E-04	0.00 %	4.867E-12	9
Fresh water lake	1.941E+04	0.01 %	1.756E+05	0.00 %							3.398E-07	1
Dissolved/Gas species (G/D)	1.754E+04	0.00 %	1.705E+05	0.00 %							3.069E-07	1
* DISSOLVED	1.753E+04	0.00 %	1.704E+05	0.00 %							3.068E-07	1
* SUSPENDED SOLIDS	4.733E+00	0.00 %	4.602E+01	0.00 %							3.068E-05	1
Solid species (S)	4.733E+00	0.00 %	4.602E+01	0.00 %							3.068E-12	1

80

Steady-State Simulation Table 1 Table 2 Graphical Output of Scale Zone Compartments

Download Table 2

Dissolved species		Emission	Inflow	Outflow	Removal	Formation (S,A,P->D)	Degradation	air-water	water-air	air-soil	soil-air	soil-water
								transport	transport	transport	transport	transport
Regional Scale												
air	aR	3.171E-01	5.933E-03	1.868E-01	7.266E-06		2.655E-28	1.362E-01	4.646E-17			
fresh water lakes	w0R	0.000E+00	4.204E-04	4.204E-04		8.279E-05	7.120E-17	3.390E-04	2.620E-22			
fresh water	w1R	3.171E-01	4.204E-04	1.270E+00		6.730E-02	7.090E-14	3.729E-03	8.697E-18			7.691E-01
coastal sea water	w2R	0.000E+00	7.298E+00	7.380E+00		8.176E-02	2.186E-14	5.932E-04	8.047E-19			
fresh water sediment	sd1R				2.646E-02	1.392E-01	3.712E-14					
coastal marine sediment	sd2R				5.417E-04	6.534E-04	2.406E-15					
natural soil	s1R	0.000E+00			2.718E-04	4.209E-03	3.508E-14			3.661E-02	1.948E-18	4.055E-02
agricultural soil	s2R	3.171E-01			4.783E-03	3.198E-01	1.357E-12			8.135E-02	3.429E-17	7.135E-01
other soil	s3R	0.000E+00			1.007E-04	1.567E-03	1.300E-14			1.356E-02	7.220E-19	1.502E-02
Continental Scale												
air	aC	0.000E+00	1.872E-01	3.322E-02	7.235E-06		2.644E-28	1.540E-01	2.550E-15			
fresh water lakes	w0C	0.000E+00	4.204E-04	4.204E-04		8.279E-05	7.120E-17	3.390E-04	2.620E-22			
fresh water	w1C	3.171E-01	4.204E-04	1.270E+00		6.730E-02	7.090E-14	3.729E-03	8.697E-18			7.691E-01
coastal sea water	w2C	0.000E+00	7.298E+00	7.380E+00		8.176E-02	2.186E-14	5.932E-04	8.047E-19			
fresh water sediment	sd1C				2.646E-02	1.392E-01	3.712E-14					
coastal marine sediment	sd2C				5.417E-04	6.534E-04	2.406E-15					
natural soil	s1C	0.000E+00			2.718E-04	4.209E-03	3.508E-14			3.661E-02	1.948E-18	4.055E-02
agricultural soil	s2C	3.171E-01			4.783E-03	3.198E-01	1.357E-12			8.135E-02	3.429E-17	7.135E-01
other soil	s3C	0.000E+00			1.007E-04	1.567E-03	1.300E-14			1.356E-02	7.220E-19	1.502E-02

81

Steady-State Simulation Table 1 Table 2 Graphical Output of Scale Zone Compartments

Graphical Output of Scale Zone Compartments

Select Scale Zone

- Regional: 3.834E+08 kg (0.00%) [Show](#)
- Continental: 3.426E+11 kg (0.14%) [Show](#)
- Moderate: 5.880E+13 kg (24.19%) [Show](#)
- Arctic: 1.450E+14 kg (59.65%) [Show](#)
- Tropical: 3.893E+13 kg (16.02%) [Show](#)

Total Mass: 2.431E+14 kg

Graphical Output of Continental Scale Compartments

Continental

Water Compartments: Fresh water (w1C), Fresh water lakes (w0C), Coastal sea water (w2C)

Soil Compartments: Natural soil (s1C), Agriculture soil (s2C), Other soil (s3C)

Sediment Compartments: Fresh water sediment (sd1C), Coastal marine sediment (sd2C)

Air (aC)

Masses (kg):

- aC: 2.218E-08 $g\ m^{-3}$
- w0C: 1.890E-07 $g\ L^{-1}$
- w1C: 4.941E-06 $g\ L^{-1}$
- w2C: 4.889E-04 $g\ L^{-1}$
- sd1C: 1.521E-04 $g\ kg(w)^{-1}$
- sd2C: 1.340E-02 $g\ kg(w)^{-1}$
- s1C: 7.249E-05 $g\ kg(w)^{-1}$
- s2C: 4.029E-05 $g\ kg(w)^{-1}$
- s3C: 7.250E-05 $g\ kg(w)^{-1}$

Masses (kg):

- aC: 1.597E+05 kg (0.00%)
- w0C: 1.756E+05 kg (0.00%)
- w1C: 1.514E+06 kg (0.00%)
- w2C: 3.407E+11 kg (99.46%)
- sd1C: 6.059E+05 kg (0.00%)
- sd2C: 1.821E+09 kg (0.53%)
- s1C: 6.179E+06 kg (0.00%)
- s2C: 3.053E+07 kg (0.01%)
- s3C: 2.289E+06 kg (0.00%)

82

84 **Figure S6.** The output window of the Steady-State Simulation in *SimpleBox4nano* presenting a summary of the steady-state simulation results, including a brief description of the steady-state
 85 calculations, Table 1 that presents the calculated steady-state concentrations, fugacities, emissions and mass, Table 2 that presents Steady-state mass flows for D species only ($kg\ s^{-1}$) and
 86 Graphical Output of Scale Zone Compartments that visualizes the mass distribution across different scales and compartments. Users can export both Table 1 and Table 2.

87

Dynamic Simulation (Time-Dependent Simulation)

Objective: To study how the chemical mass evolves over time in each environmental compartment, while emissions are constant.

Mathematical Basis: The dynamic behaviour is modelled using the following first order differential equation:

$$\frac{dM(t)}{dt} = \mathbf{K} \cdot \mathbf{M}(t) + \mathbf{E}$$

where:

K (s⁻¹) is the matrix of transfer rate coefficients between compartments,

M(t) (kg) is the vector of masses (or fugacities) in compartments at time *t*,

E (kg s⁻¹) is the vector of constant emission rates

The system experiences continuous inflow (constant emissions) and outflows (due to inter-compartment transfer and degradation). Over time, the mass in each compartment approaches a steady state. The system of differential equations is solved numerically using 4th order Runge-Kutta method for capturing how the system moves from an initial state (e.g., zero mass) toward the steady state.

Graphical Output of Scale Zone Compartments

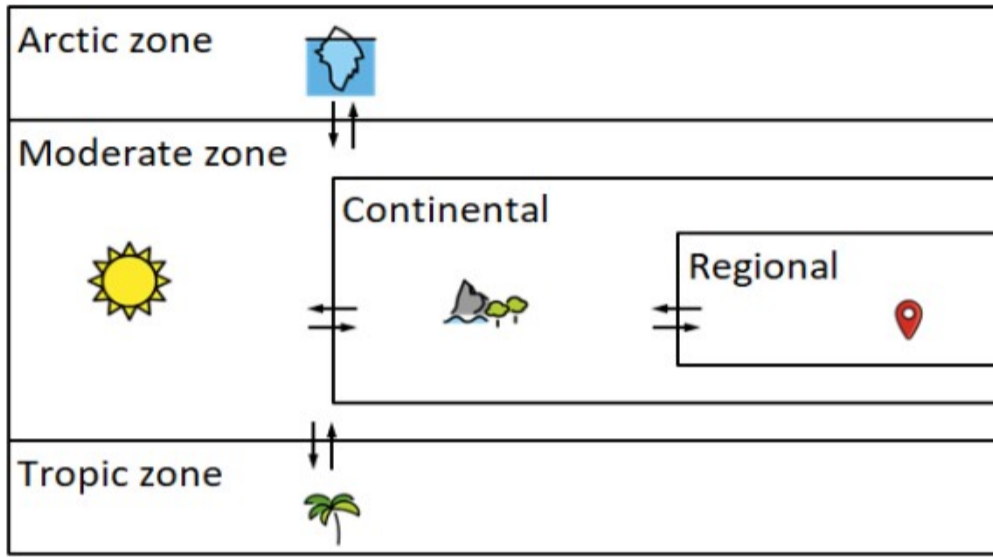

- Regional [Show](#)
- Continental [Show](#)
- Moderate [Show](#)
- Arctic [Show](#)
- Tropical [Show](#)

89

Graphical Output of Regional Scale Compartments

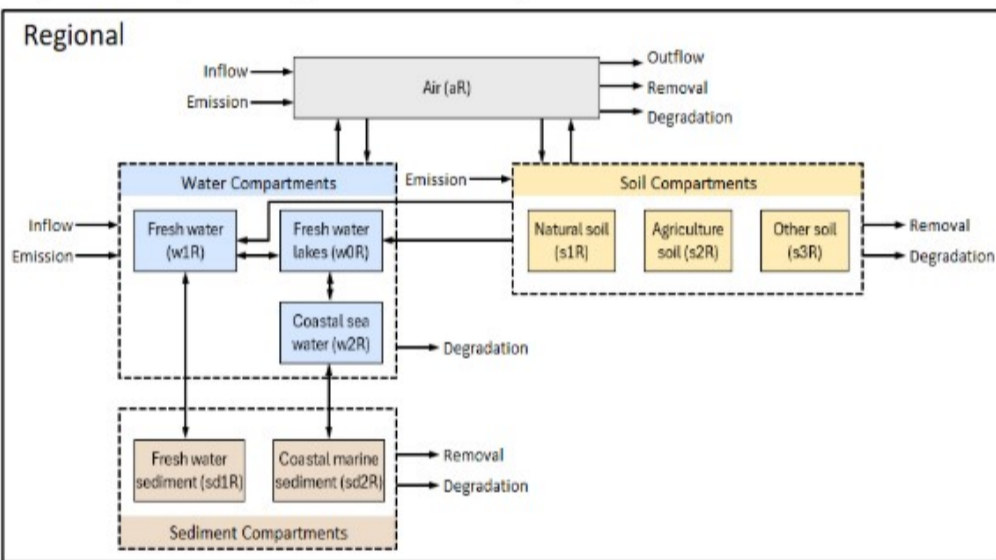

- | | | | | | | | | | |
|-------|-------|-------|-------|-------|-------|-------|-------|-------|------|
| aRG | aRS | aRA | aRP | cwRS | cwRA | cwRP | w0RD | w0RS | w0RA |
| w0RP | w1RD | w1RS | w1RA | w1RP | w2RD | w2RS | w2RA | w2RP | |
| sd0RD | sd0RS | sd0RA | sd0RP | sd1RD | sd1RS | sd1RA | sd1RP | sd2RD | |
| sd2RS | sd2RA | sd2RP | s1RD | s1RS | s1RA | s1RP | s2RD | s2RS | |
| s2RA | s2RP | s3RD | s3RS | s3RA | s3RP | | | | |

Time needed to reach equilibrium (steady-state) in the Regional scale:

- aRG reaches equilibrium (steady-state) at 6.0 days
- aRS reaches equilibrium (steady-state) at 4.0 days
- aRA reaches equilibrium (steady-state) at 21.0 days
- aRP reaches equilibrium (steady-state) at 5.0 days
- cwRS reaches equilibrium (steady-state) at 5.0 days
- cwRA reaches equilibrium (steady-state) at 22.0 days
- cwRP reaches equilibrium (steady-state) at 5.0 days
- w0RD reaches equilibrium (steady-state) at 2268.0 days
- w0RS reaches equilibrium (steady-state) at 5.0 days

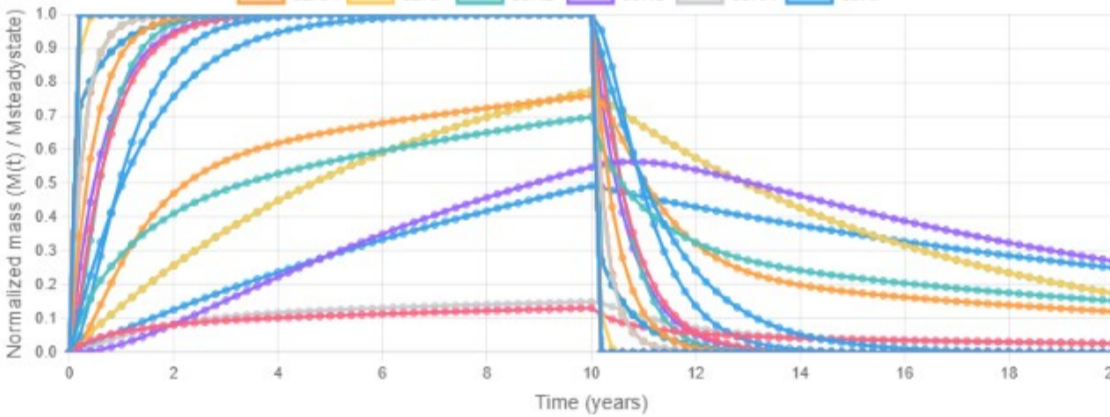

90

91

92

93

Figure S7. The output window of the Dynamic Simulation in *SimpleBox4nano* web application, presenting a brief description of the quasi-dynamic simulation calculation and presenting a graphical representation of mass distribution across different scales. Users can select a specific scale using the 'Show' button to visualize the dynamic evolution of mass, normalized by the steady-state mass, as a function of time.

94

95 S6. Output window after selecting ‘Calculate Fate Factors’

Calculate Fate Factor (FF) in days Back

$$FF_{i,j} = \frac{m_j(t)}{\dot{m}_i}$$

Where:
 $m_j(t)$ is the dynamic mass in receiving compartment j at time t .
 \dot{m}_i is the emission mass flow (kg/day) from the single Continental emission compartment i .

Substance:

Landscape:

Emission Compartment:

Number of years:

Fate Factor in days	
Receiving Compartment	Number of Days
Air	5.3
Fresh water lake	2.9
Fresh water	14.4
Coastal sea water	158.1
Natural soil	60.7
Agricultural soil	241.9
Other soil	22.5

Calculate

96

97 **Figure S8.** Output of the ‘Calculate Fate Factors’ function in the *SimpleBox4nano* web application. Computation is only enabled
 98 under continental-scale scenarios with a single specified emission compartment. Users may also define a custom time (in years)
 99 to analyze the fate behavior over a relevant temporal scale.

100 S7. REST APIs

The screenshot shows a REST client interface. At the top, the URL `https://enaloscloud.novamechanics.com/insight/apis/simplebox4nano/results/` is displayed. Below the URL, the HTTP method is set to `POST`. The request body is a JSON object with the following structure:

```
1  {
2    "substance": "nanoparticle",
3    "scenario": "default scenario",
4    "e_w0RS": 1000,
5    "e_w1RS": 0,
6    "e_w2AS": 0,
7    "e_w2RD": 0,
8    "e_aCG": 0,
9    "e_s3RS": 0,
10   "e_w1CS": 0,
11   "e_w2MD": 0,
12   "e_aAG": 0,
13   "e_w2AD": 0,
14   "e_w0CD": 0,
15   "e_sAS": 0,
16   "e_sAD": 0,
17   "e_w0CS": 0,
18   "e_aTG": 0,
19   "e_s1CD": 0,
20   "e_w2CS": 0,
21   "e_w1RD": 0,
22   "e_w2MS": 0,
23   "e_sMD": 0,
24   "e_aCS": 0,
25   "e_sMS": 0,
26   "e_sTS": 0,
27   "e_aRS": 0,
28   "e_s3CS": 0,
29   "e_w1CD": 0,
30   "e_w2CD": 0,
31   "e_s2RS": 0,
32   "e_s1CS": 0,
```

101

```
33 "e_s2CD": 0,  
34 "e_w2RS": 0,  
35 "e_s2CS": 0,  
36 "e_s1RS": 0,  
37 "e_w0RD": 0,  
38 "e_aMS": 0,  
39 "e_s1RD": 0,  
40 "e_aTS": 0,  
41 "e_sTD": 0,  
42 "e_w2TD": 0,  
43 "e_w2TS": 0,  
44 "e_aAS": 0,  
45 "e_aRG": 0,  
46 "e_s3CD": 0,  
47 "e_aMG": 0,  
48 "e_s2RD": 0,  
49 "e_s3RD": 0  
50 }
```

102

Body Cookies Headers (7) Test Results

Pretty Raw Preview Visualize JSON 

```
75 [  
76   "Dissolved/Gas species (G/D)",  
77   "1.65E-13",  
78   "0.0%",  
79   "8.30E-12",  
80   "0.0%",  
81   "2.73E-10",  
82   "0.0%",  
83   "1.19E-11",  
84   "0.0%",  
85   "4.98E-09",  
86   "0.0%",  
87   "7.18E-25",  
88   "1.15E-24",  
89   "3.52E-24",  
90   "2.81E-25",  
91   "3.91E-23",  
92   "g.m-3",  
93   "2.60E-23",  
94   "4.18E-23",  
95   "1.28E-22",  
96   "9.39E-24",  
97   "1.48E-21"  
98 ],
```

103

104
105

Figure S9. Using Postman to test the functionality of a 'POST' request for the endpoint <https://enaloscloud.novamechanics.com/insight/apis/simplebox4nano/results/>, including input data and response validation.

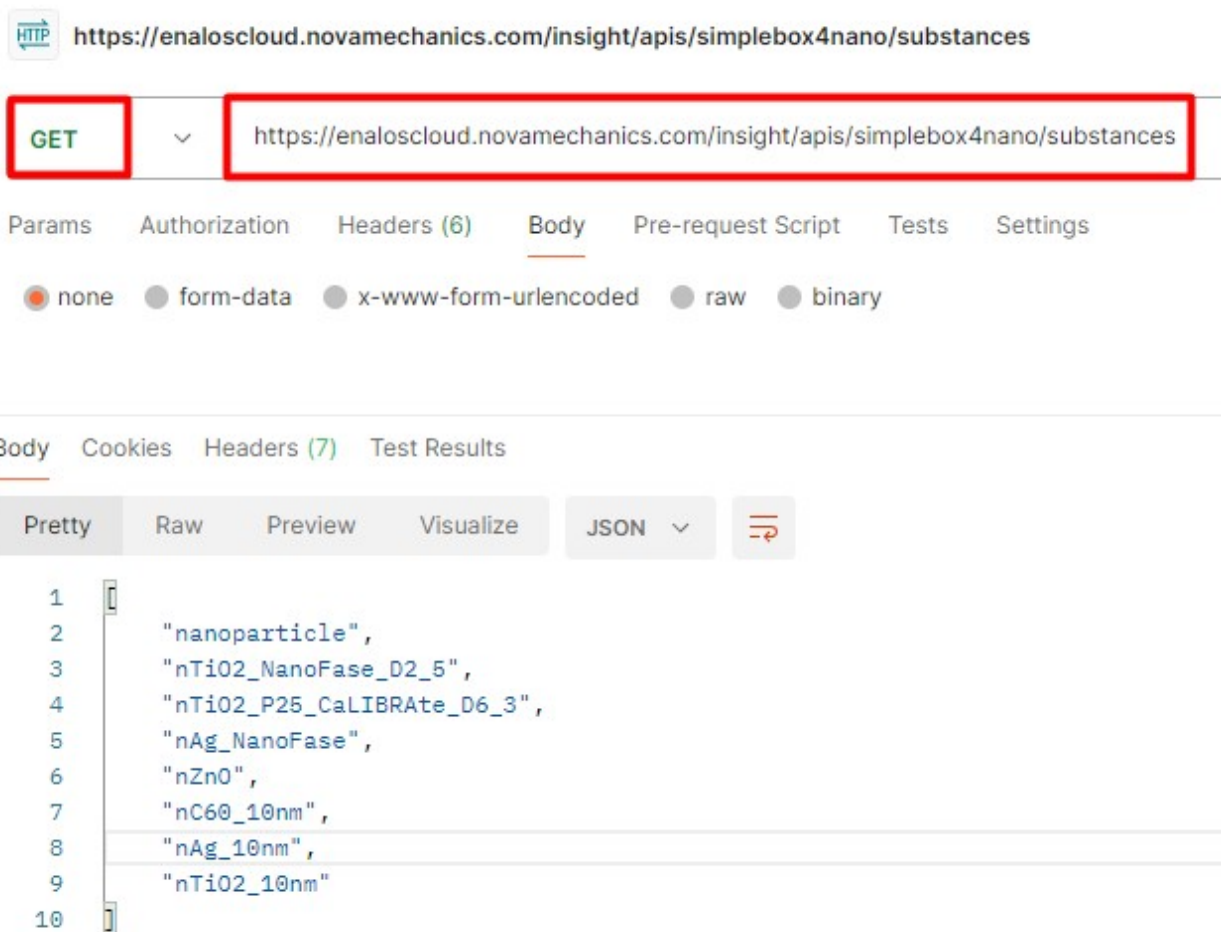

106
107
108
109

Figure S10. Using Postman to test the functionality of a 'GET' request for the endpoint <https://enaloscloud.novamechanics.com/insight/apis/simplebox4nano/substances>, verifying the request parameters and the expected response.

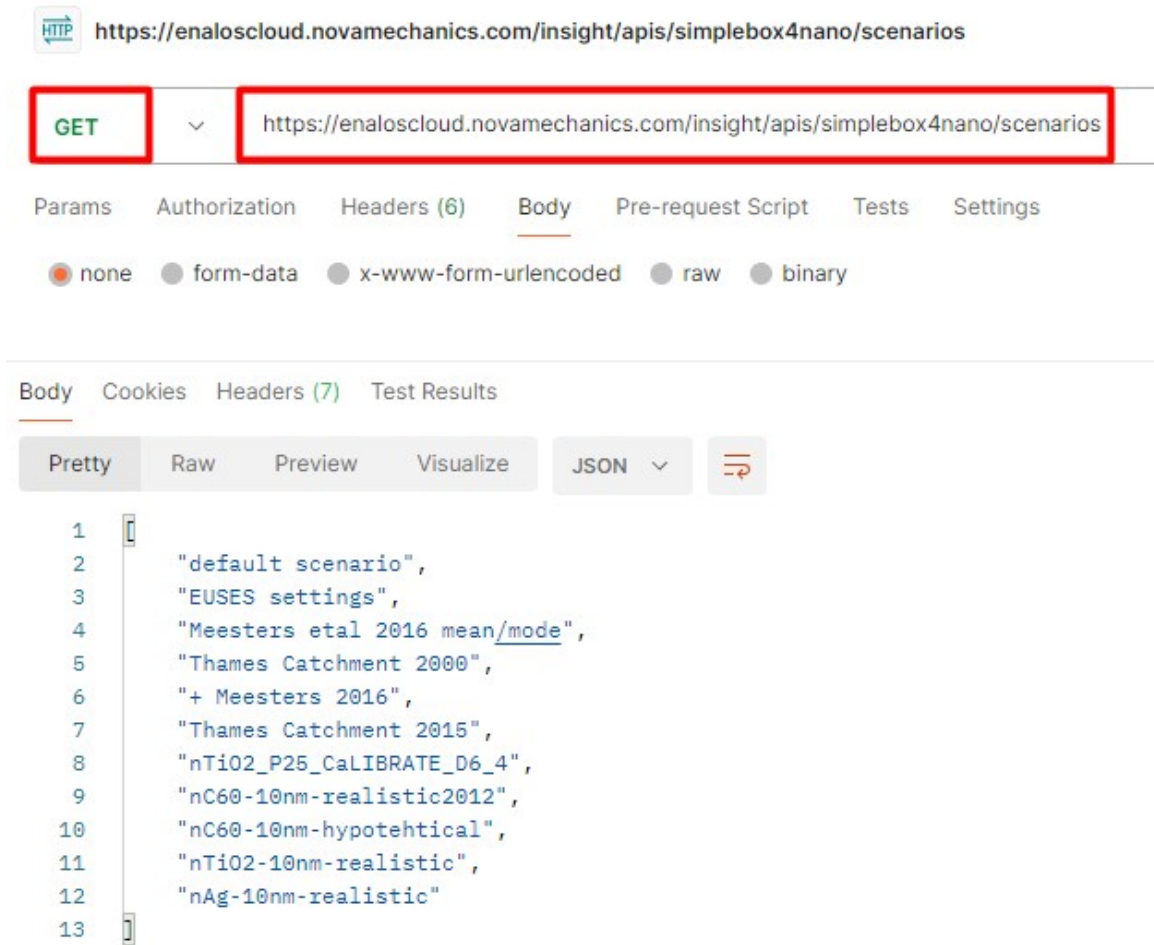

110

111

112

113

Figure S11. Using Postman to test the functionality of a 'GET' request for the endpoint <https://enaloscloud.novamechanics.com/insight/apis/simplebox4nano/scenarios>, verifying the request parameters and the expected response.

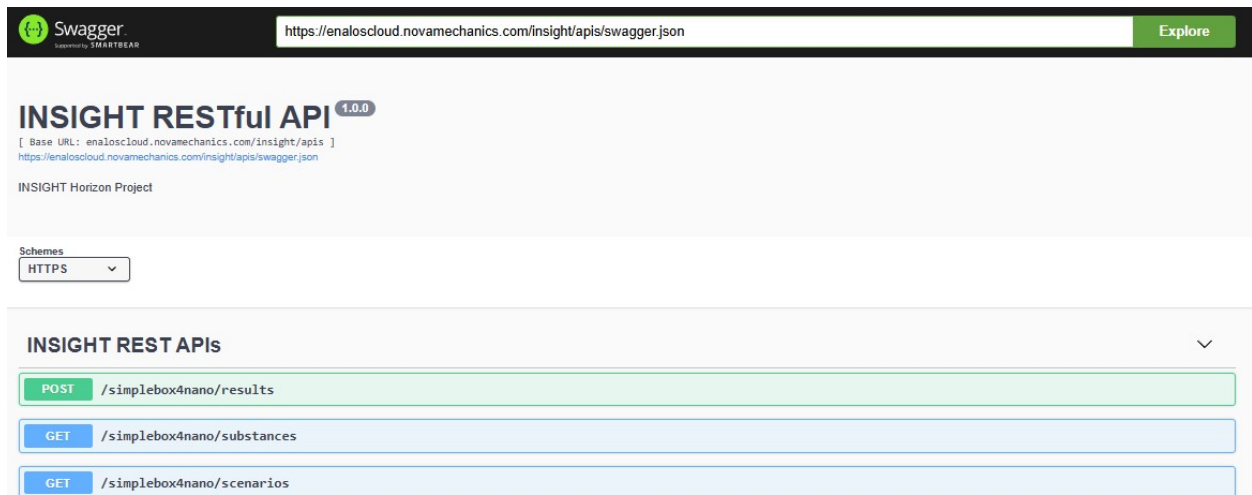

114

115

116

117

Figure S12. Snapshot of the Swagger/OpenAPI interface for the *SimpleBox4nano* RESTful API hosted on the Enalos Cloud platform. The interface documents the available POST and GET endpoints and allows interactive inspection and testing of API requests and responses.

118 **S8. Environmental fate modelling – *SimpleBox4Planet* vs. *SimpleBox4nano***

Choose Nanomaterial

Nanomaterial Substance

Substance Properties

CAS	<input type="text"/>	ChemClass	<input type="text" value="Nano"/>	Molecular Weight [g.mol ⁻¹]	<input type="text" value="65.38"/>		
RadS [nm]	<input type="text" value="35.6428571428"/>	RhoS [kg.m-3]	<input type="text" value="5850"/>	AHamakerSP.w [J]	<input type="text" value="1.69571428571"/>	Tm [°C]	<input type="text" value="420"/>
pKa [-]	<input type="text" value="7"/>	Pvap25 [Pa]	<input type="text" value="1e-20"/>	Sol25 [mg.L ⁻¹]	<input type="text" value="1e-20"/>	Kaw [-]	<input type="text" value="1e-20"/>
Kow [-]	<input type="text" value="2750"/>	Ksw [-]	<input type="text" value="50"/>	Kdeg(air) [s ⁻¹]	<input type="text" value="1e-20"/>	Kdeg(water) [s ⁻¹]	<input type="text" value="1e-20"/>
Kdeg(sed) [s ⁻¹]	<input type="text" value="1e-20"/>	Kdeg(soil) [s ⁻¹]	<input type="text" value="1e-20"/>	<input type="button" value="Show More Fields"/>			

119

120

121

Figure S13. Physicochemical properties of nanoparticle used in the *SimpleBox4nano* web application to simulate its environmental fate and transport.

122 **S8.1 Emissions of dissolved species in water (at the moderate scale zone)**

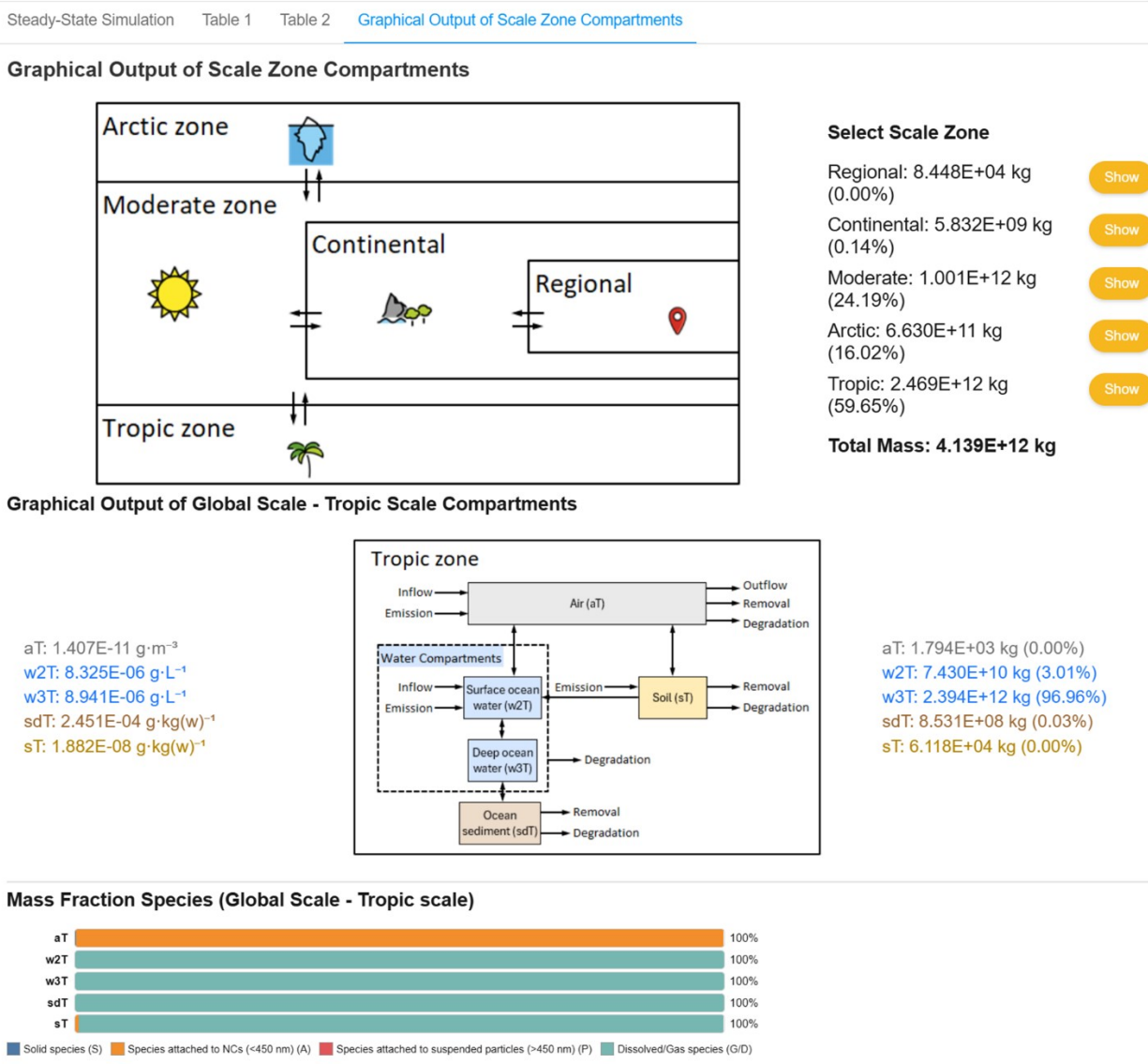

123
124
125
126
127
128

Figure S14. Graphical output of the steady-state mass of nanoparticle as generated from *SimpleBox4nano* web application per scale zone for solid-species emission to water (1000 t y⁻¹) applied at the moderate (global-scale) zone. The figure reports (top) the steady-state mass distribution across scale zones, (middle) the corresponding mass distribution among tropic-zone compartments (aT, w2T, w3T, sdT, sT) together with the associated compartmental concentrations, and (bottom) the mass fraction of species (S, A, P, G/D) at the tropic scale.

Calculate Fate Factor (FF) in days

Back

$$FF_{i,j} = \frac{m_j(t)}{\dot{m}_i}$$

Where:

$m_j(t)$ is the dynamic mass in receiving compartment j at time t .

\dot{m}_i is the emission mass flow (kg/day) from the single Continental emission compartment i .

Substance

Landscape

Emission Compartment:

Number of years

Fate Factor in days	
Receiving Compartment	Number of Days
Air	0.0
Fresh water lake	0.0
Fresh water	0.0
Coastal sea water	437.8
Natural soil	0.0
Agricultural soil	0.0
Other soil	0.0

Calculate

129

130 **Figure S15.** Fate factor (FF, days) graphical output generated by the *SimpleBox4nano* web application for the default engineered
131 nanomaterial, calculated over a 100-year simulation horizon for solid-species emission to continental sea water ($1000 \text{ t}\cdot\text{y}^{-1}$). The
132 interface reports the compartment-specific fate factors (in days) for receiving compartments (air, fresh water lake, fresh water,
133 coastal sea water, natural soil, agricultural soil, other soil).

134

135 **S8.2 Emissions of dissolved species in soil (at the moderate scale zone)**

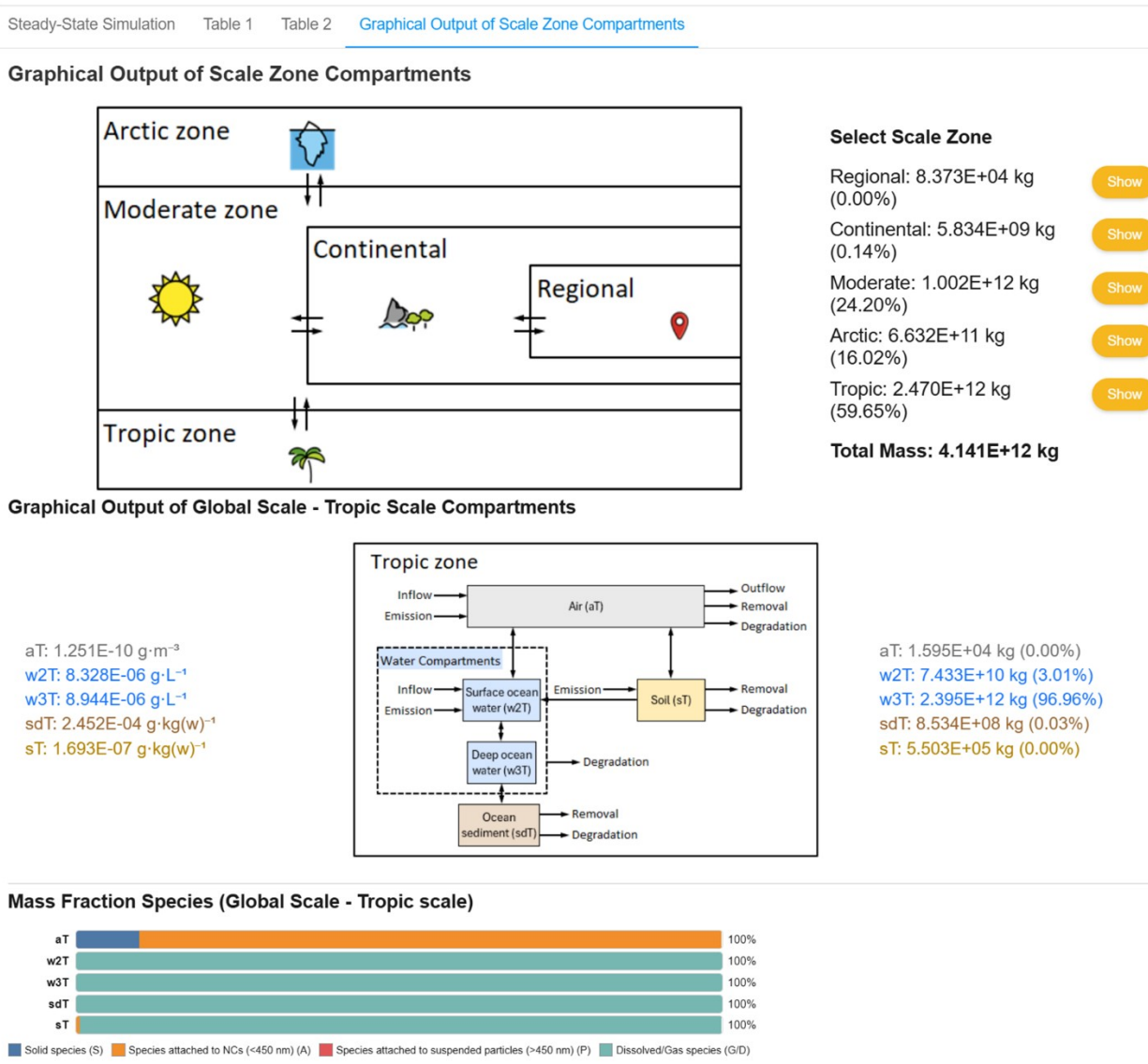

136
137
138
139
140
141
142

Figure S16. Graphical output of the steady-state mass of nanoparticle as generated from *SimpleBox4nano* web application per scale zone for solid-species emission to soil (1000 t y⁻¹) applied at the moderate (global-scale) zone. The figure reports (top) the steady-state mass distribution across scale zones, (middle) the corresponding mass distribution among tropic-zone compartments (aT, w2T, w3T, sdT, sT) together with the associated compartmental concentrations, and (bottom) the mass fraction of species (S, A, P, G/D) at the tropic scale.

$$FF_{i,j} = \frac{m_j(t)}{\dot{m}_i}$$

Where:

$m_j(t)$ is the dynamic mass in receiving compartment j at time t .

\dot{m}_i is the emission mass flow (kg/day) from the single Continental emission compartment i .

Substance

Landscape

Emission Compartment: Natural soil

Number of years

Fate Factor in days	
Receiving Compartment	Number of Days
Air	0.0
Fresh water lake	0.0
Fresh water	155.8
Coastal sea water	424.6
Natural soil	2,311.8
Agricultural soil	0.0
Other soil	0.0

Calculate

143
144
145
146
147

Figure S17. Fate factor (FF, days) graphical output generated by the *SimpleBox4nano* web application for the default engineered nanomaterial, calculated over a 100-year simulation horizon for solid-species emission to continental natural soil ($1000 \text{ t}\cdot\text{y}^{-1}$). The interface reports the compartment-specific fate factors (in days) for receiving compartments (air, fresh water lake, fresh water, coastal sea water, natural soil, agricultural soil, other soil).

148

149 S9. Sensitivity Exploration (selection of lower and upper bounds)

150 The nanoparticle radius range (1-100 nm) aligns with the commonly adopted size range for
151 nanomaterials, while also matching typical primary particle sizes observed in microscopy and DLS
152 characterisation of commercially relevant ENMs.¹ The density range (900-30 000 kg m⁻³) is chosen to cover
153 low-density organic and polymeric ENMs and extend to very dense metals and alloys, thereby allowing the
154 model to represent both buoyant and strongly settling particles in different compartments.² The acid
155 dissociation constant (pK_a) interval (-2 to 14) captures the full range of strongly acidic sulfonic/sulfate
156 functional groups used on oxide or latex nanoparticles³ through to highly basic guanidinium- and amine-
157 rich coatings employed on AuNPs, liposomes and polymeric carriers.⁴ The melting temperature (T_m) range
158 (15-4000 °C) reflects the diversity of ENMs from low-melting organic/polymeric nanoobjects to refractory
159 metal oxides and high-temperature ceramics used in catalysis or coatings.⁵ Partition properties (K_{aw} , K_{ow} ,
160 K_{sw} , P_{vap} and Sol) are primarily relevant for dissolved or molecular species that arise from ENM
161 transformation (e.g. metal ions, small organic ligands, degradation products). The ranges in Table 1 are
162 selected to be at least as wide as those employed in previous multimedia fate assessments of organic
163 chemicals, ensuring that hydrophilic, amphiphilic and highly hydrophobic transformation products can be
164 represented within a single unified parameter space.⁶⁻⁸ The Hamaker constant range (10⁻²¹-10⁻¹⁹ J) is
165 consistent with experimentally and theoretically derived values for metal oxides, metals and carbonaceous
166 particles in water, which typically lie in the 10⁻²¹-10⁻¹⁹ J interval depending on medium composition and
167 surface coatings.⁹ Kinetic parameters (transformation, degradation and dissolution constants) are
168 deliberately defined over several orders of magnitude to cover extremely persistent ENMs, such as inert
169 oxides, as well as rapidly transforming or dissolving materials (e.g. sulfidising Ag NPs or readily dissolving
170 ZnO).¹⁰ Attachment efficiencies between 10⁻¹⁰ and 1 reflect the wide range of aggregation behaviours
171 observed for ENMs interacting with natural colloids or suspended solids, where electrostatic and steric
172 stabilisation can suppress attachment far below unity.¹¹

173

174 S10. Halton Design

175 S10.1 Total mass of D-species, S-species, A-species, P-species

176 S10.1.1 Air

177 S10.1.1.1 Dissolved/Gas species

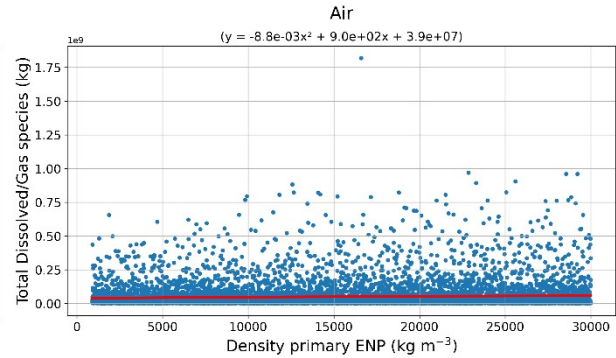
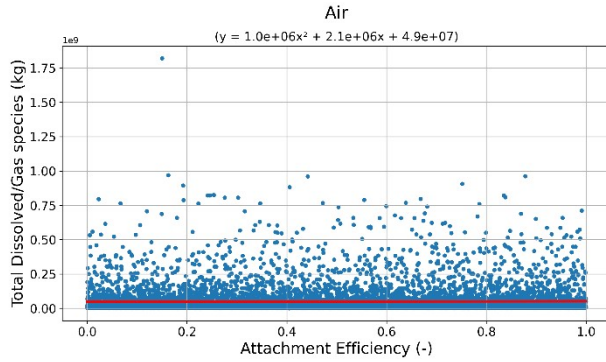

178

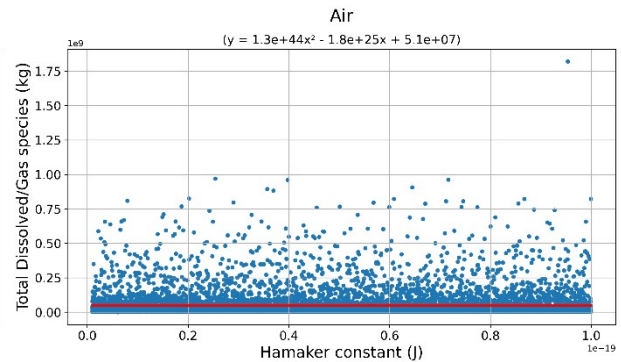
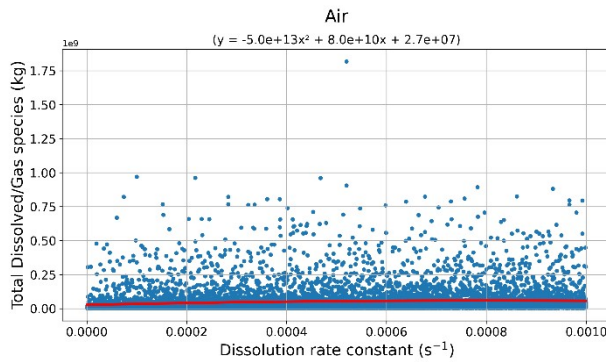

179

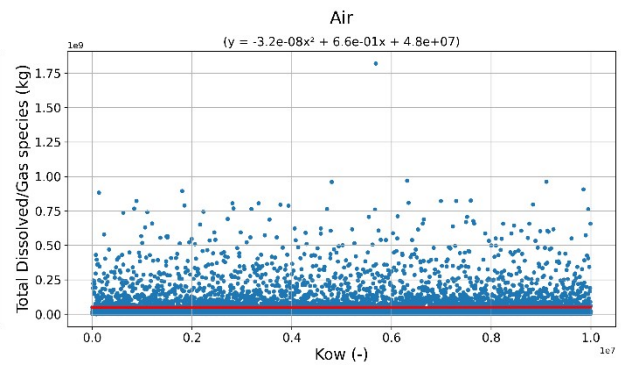
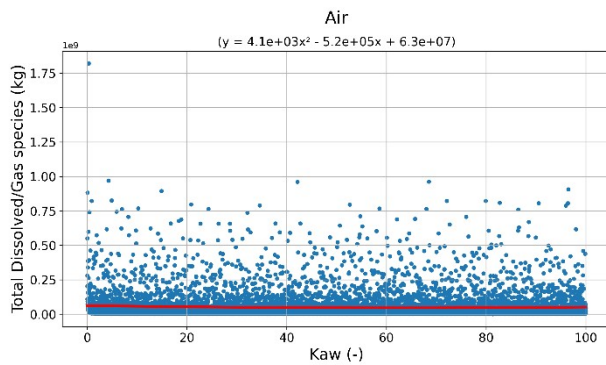

180

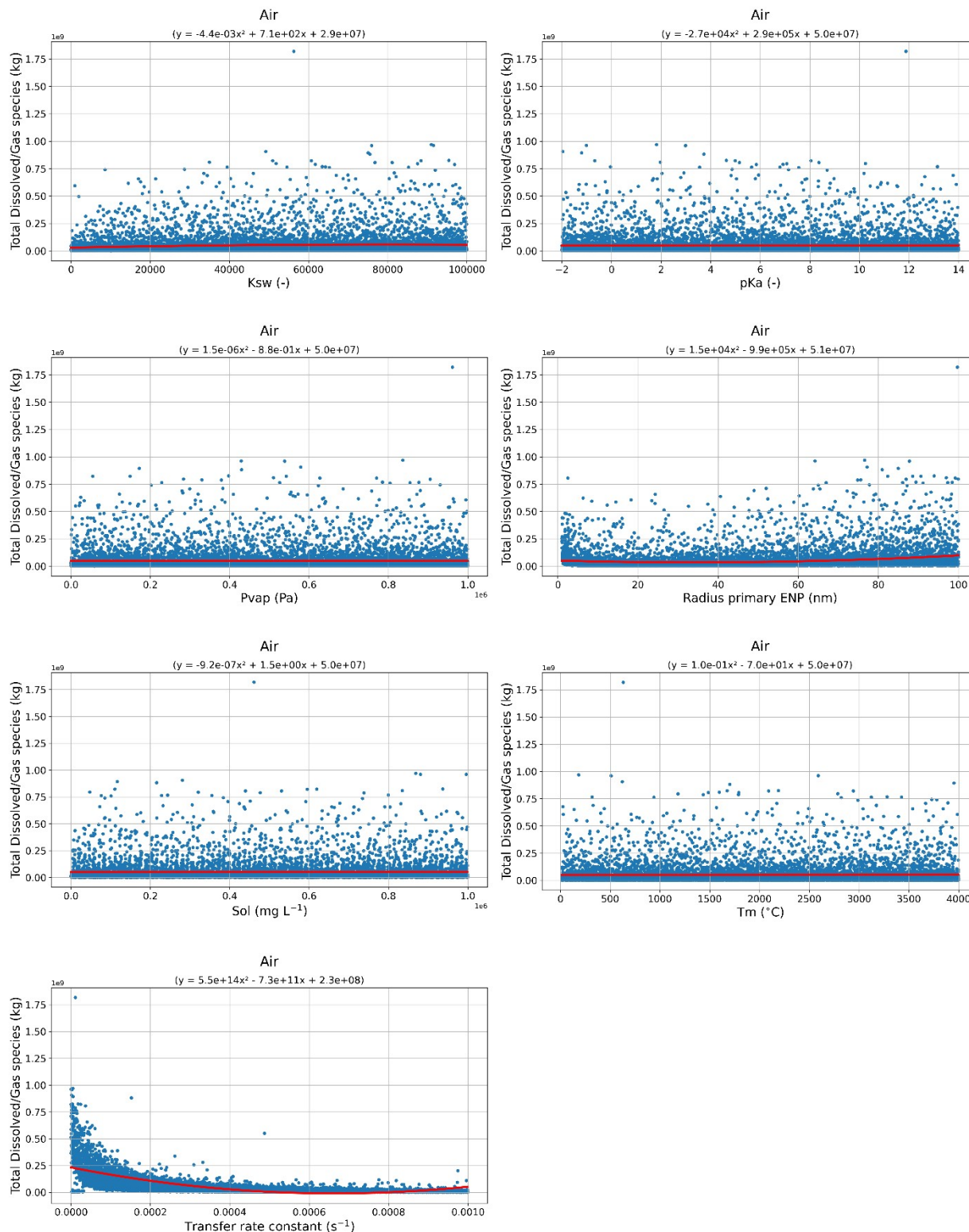

181

182

183

184

185

186

187

188

189

Figure S18. Scatter plots of the 10,000 simulation outputs generated with the *SimpleBox4nano* web application for the dissolved/gas species (D-species) under the solid-species emission scenario (1000 t y^{-1}) to the air compartment at the moderate (global-scale) zone. Each panel corresponds to one of the 13 physicochemical parameters (x-axis), plotted against the resulting total dissolved/gas mass (kg) at steady state (y-axis). Fitted second-order polynomial curves are included in each panel to provide an initial visual indication of non-linear trends.

190 **S10.1.1.2 Total Solid species**

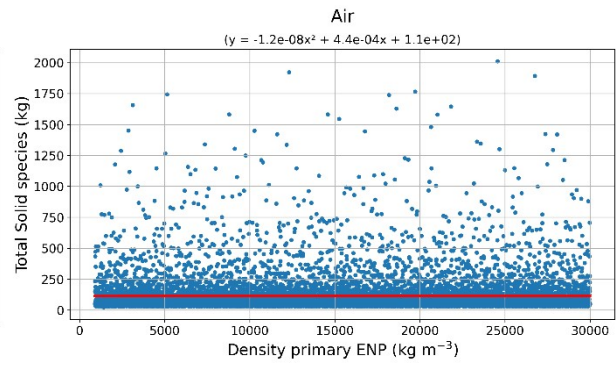
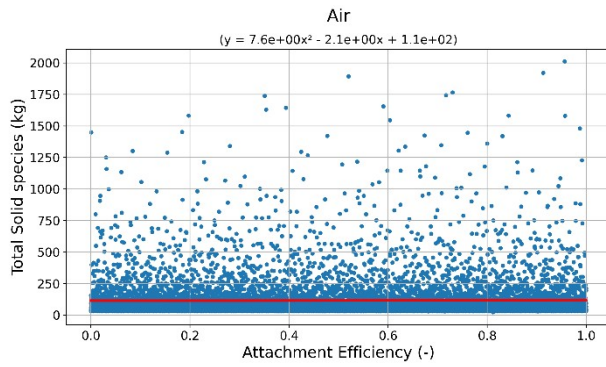

191

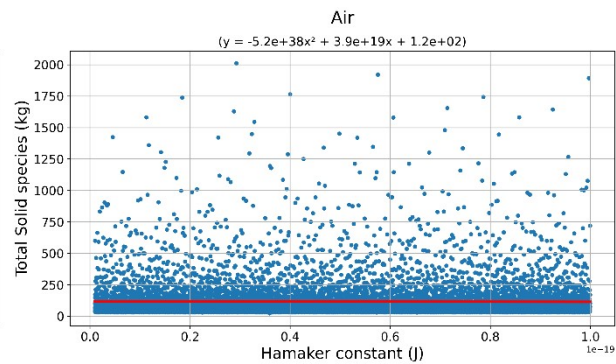
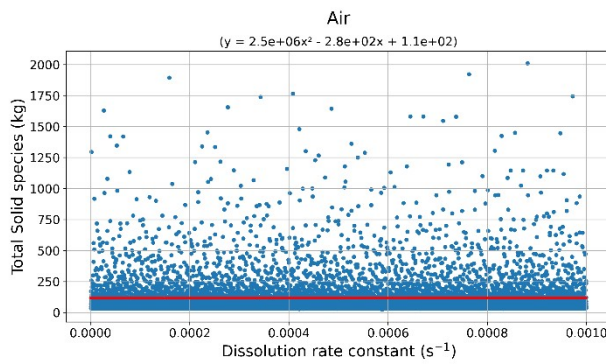

192

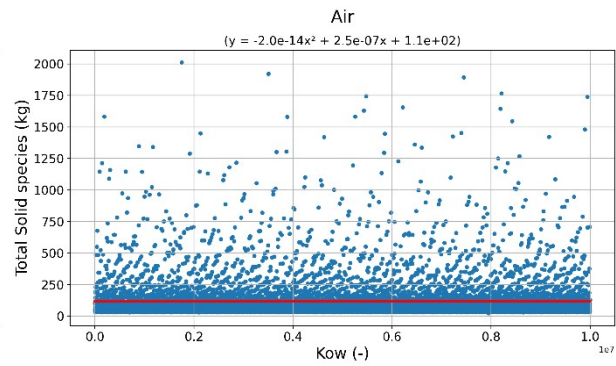
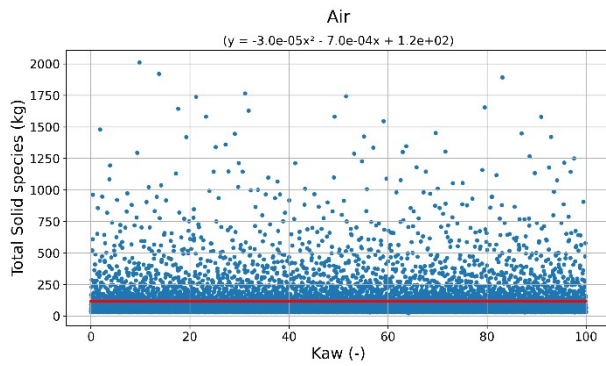

193

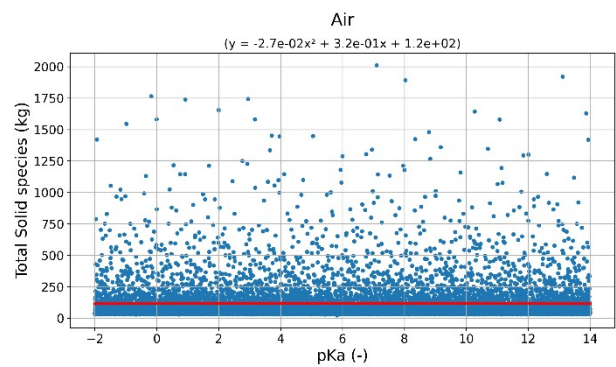
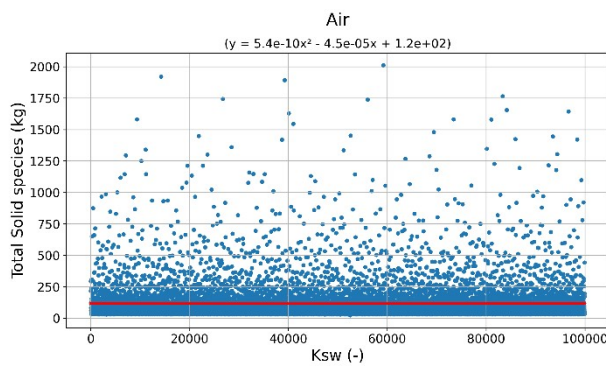

194

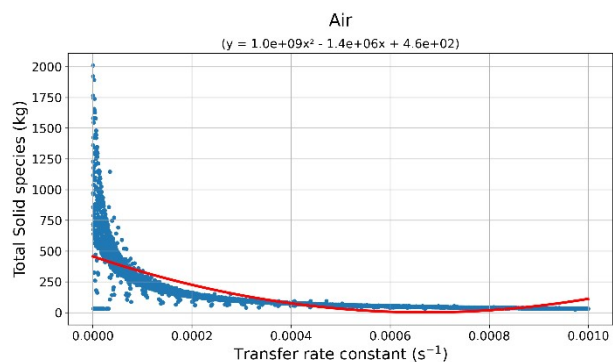
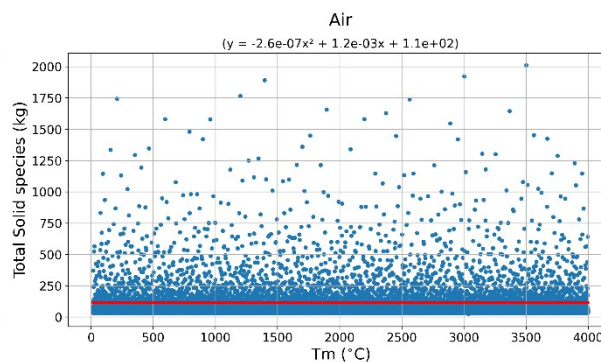
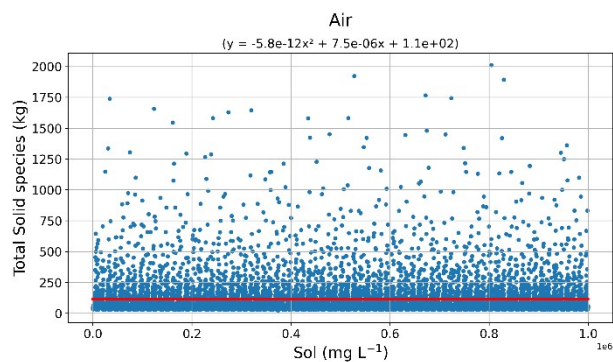
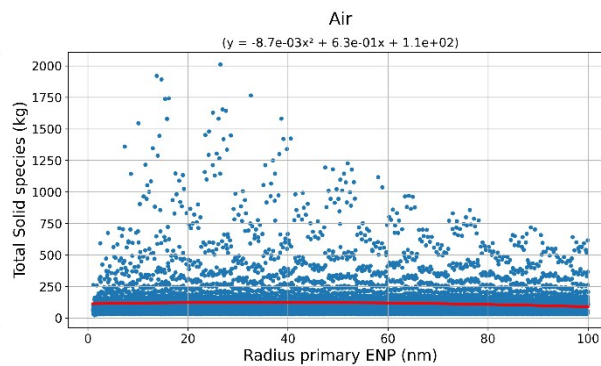
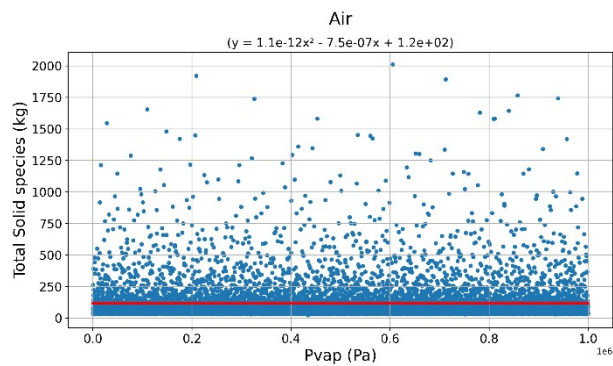

195

196

197

198 **Figure S19.** Scatter plots of the 10,000 simulation outputs generated with the *SimpleBox4nano* web application for the solid
 199 species (S-species) under the solid-species emission scenario (1000 t y⁻¹) to the air compartment at the moderate (global-scale)
 200 zone. Each panel corresponds to one of the 13 physicochemical parameters (x-axis), plotted against the resulting total
 201 dissolved/gas mass (kg) at steady state (y-axis). Fitted second-order polynomial curves are included in each panel to provide an
 202 initial visual indication of non-linear trends.

203

204 **S10.1.1.3 Total species attached to NCs (< 450 nm)**

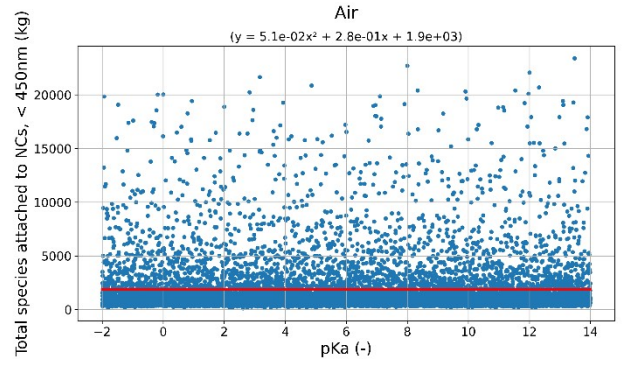
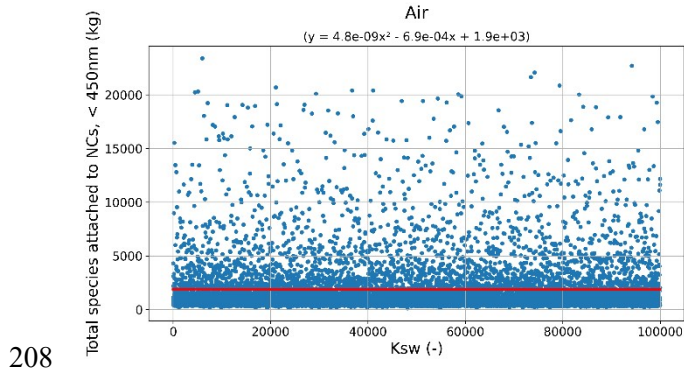
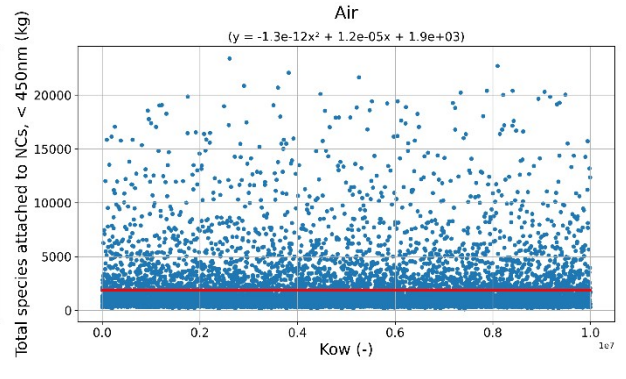
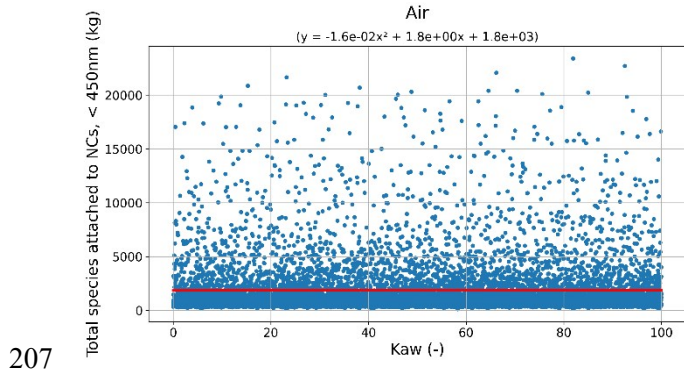
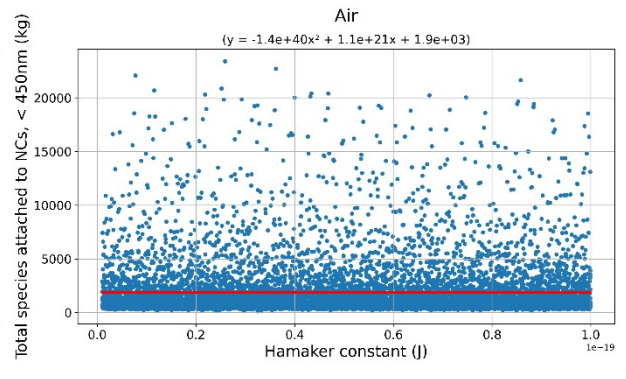
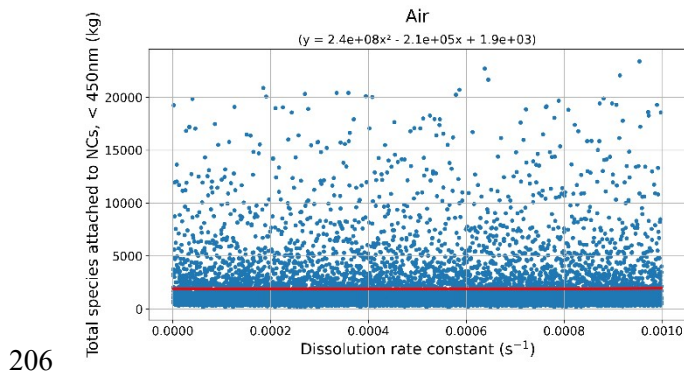
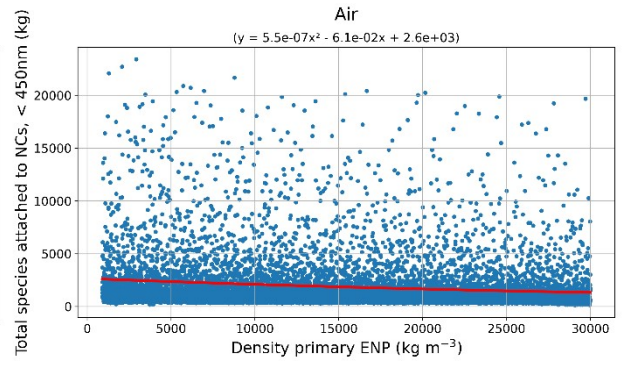
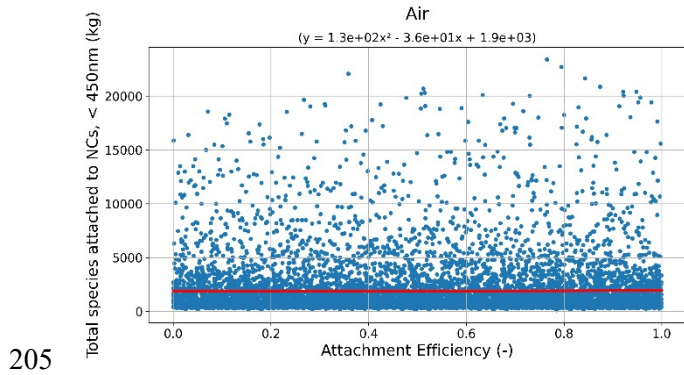

209

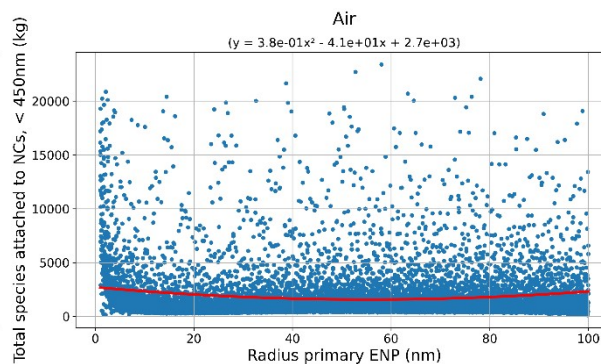
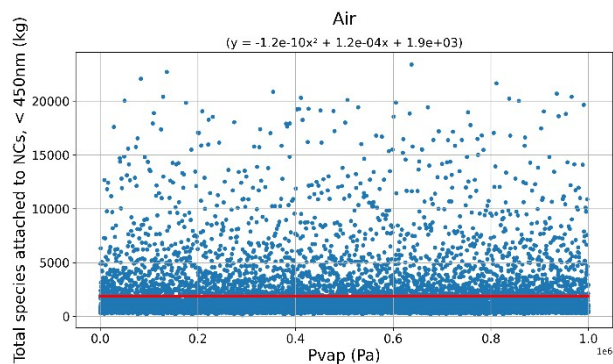

210

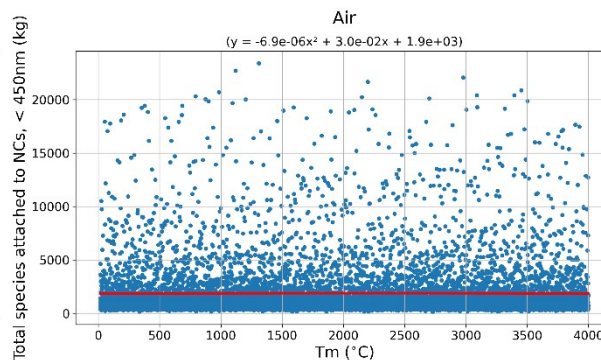
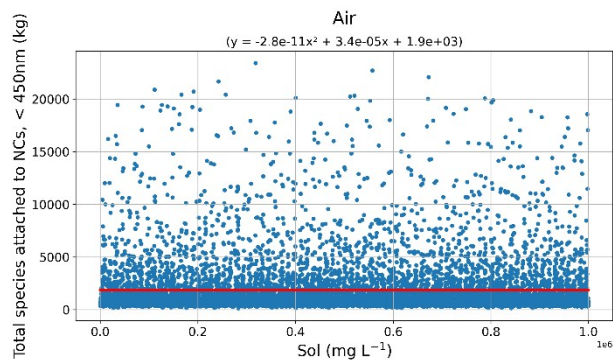

211

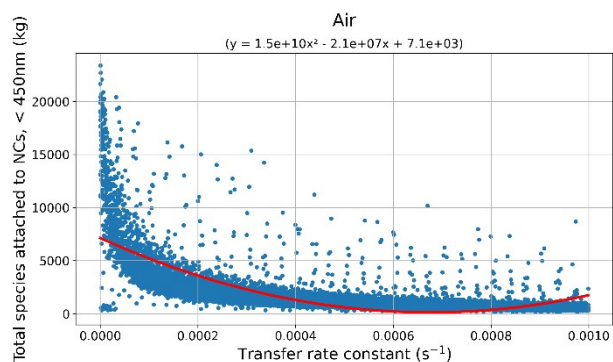

212

213 **Figure S20.** Scatter plots of the 10,000 simulation outputs generated with the *SimpleBox4nano* web application for the hetero-
 214 aggregated species attached to natural colloids (< 450 nm) (A) under the solid-species emission scenario (1000 t y^{-1}) to the air
 215 compartment at the moderate (global-scale) zone. Each panel corresponds to one of the 13 physicochemical parameters (x-axis),
 216 plotted against the resulting total dissolved/gas mass (kg) at steady state (y-axis). Fitted second-order polynomial curves are
 included in each panel to provide an initial visual indication of non-linear trends.

217

218 **S10.1.1.4 Total species attached to suspended particles (> 450 nm)**

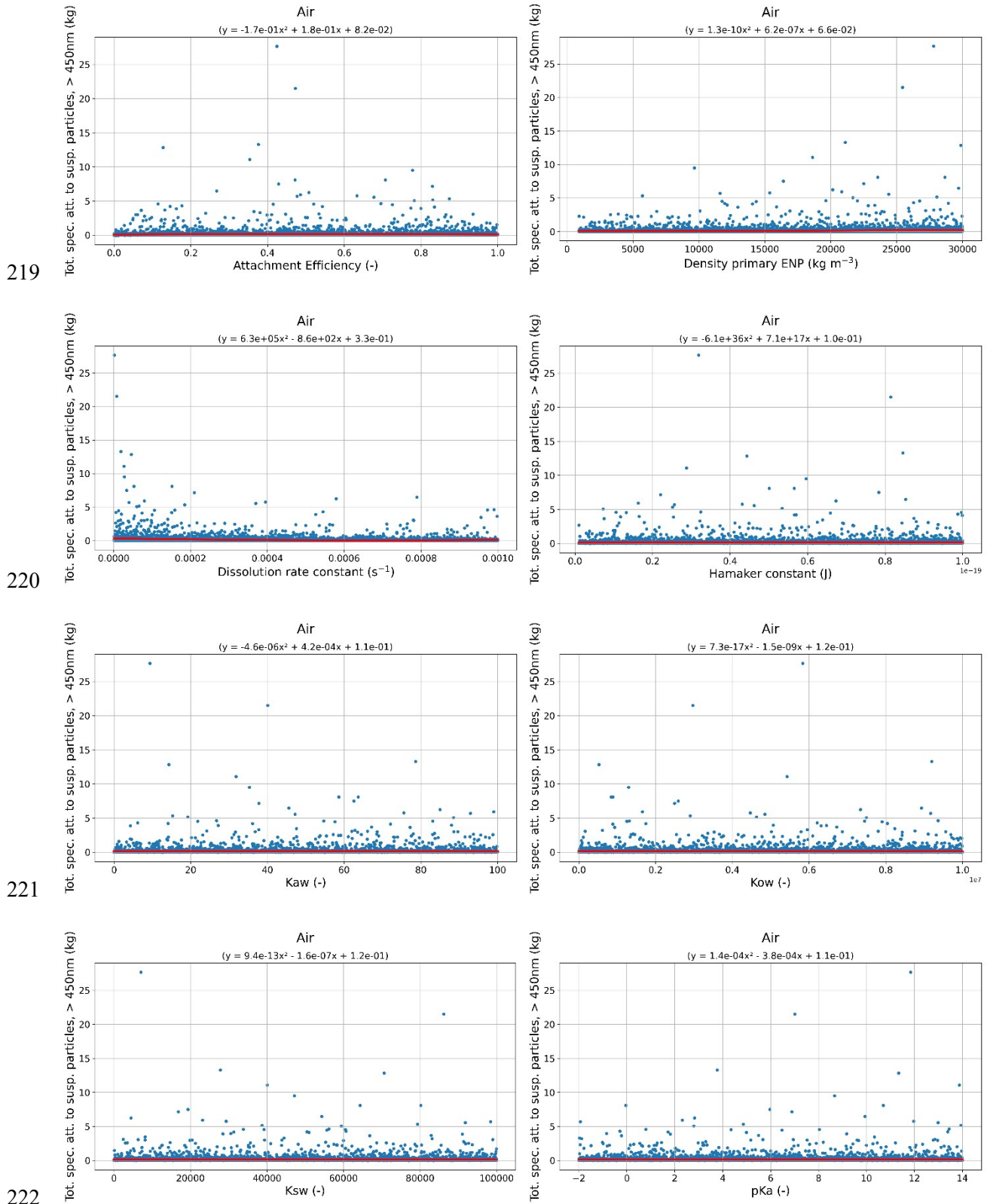

223

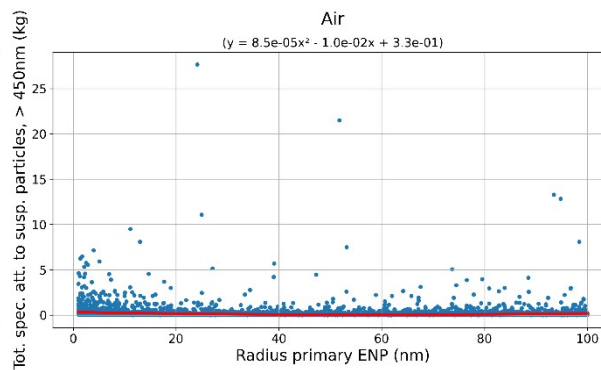
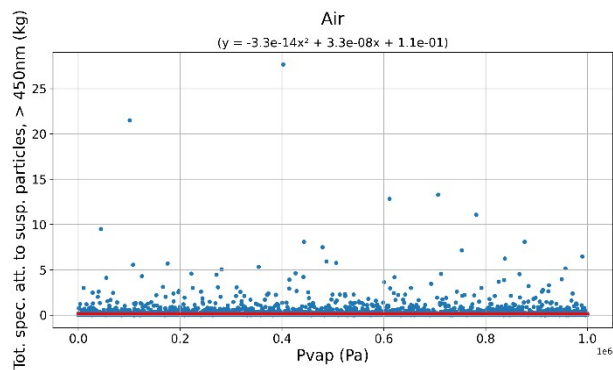

224

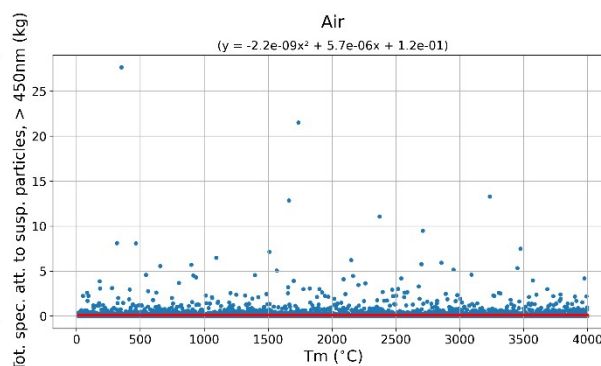
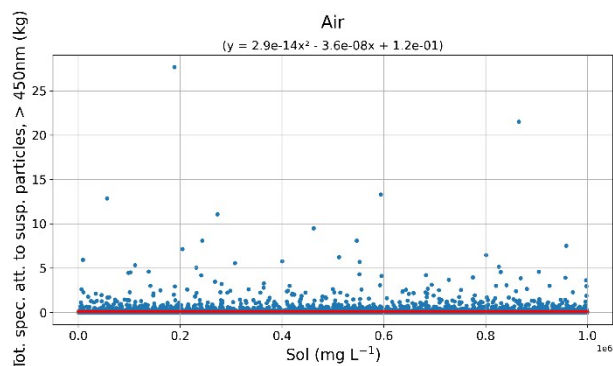

225

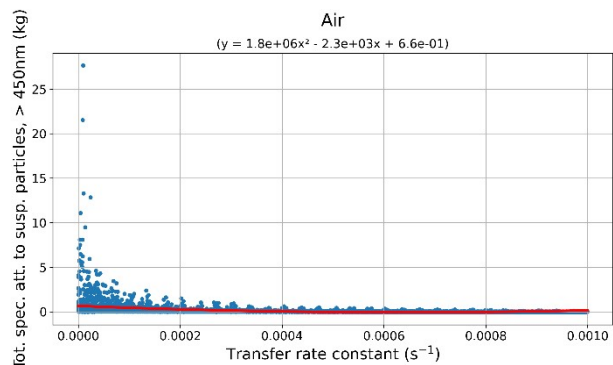

226

227

228

229

230

Figure S21. Scatter plots of the 10,000 simulation outputs generated with the *SimpleBox4nano* web application for the species attached to suspended particles (> 450 nm) (P) under the solid-species emission scenario (1000 t y^{-1}) to the air compartment at the moderate (global-scale) zone. Each panel corresponds to one of the 13 physicochemical parameters (x-axis), plotted against the resulting total dissolved/gas mass (kg) at steady state (y-axis). Fitted second-order polynomial curves are included in each panel to provide an initial visual indication of non-linear trends.

231

232 S10.1.2 Soil

233 S10.1.2.1 Dissolved/Gas species

234

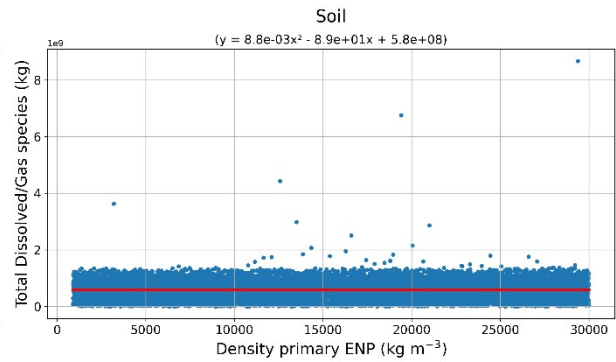
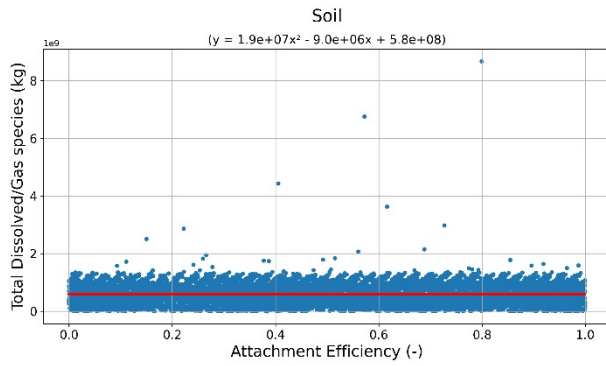

235

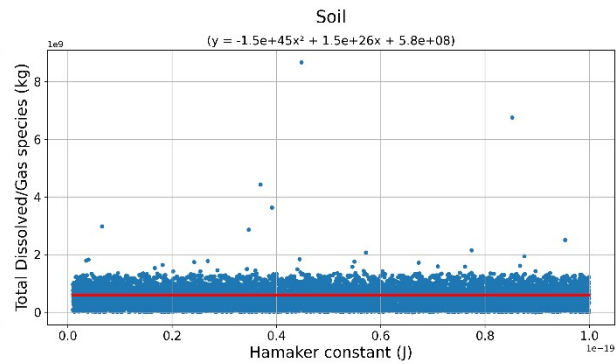
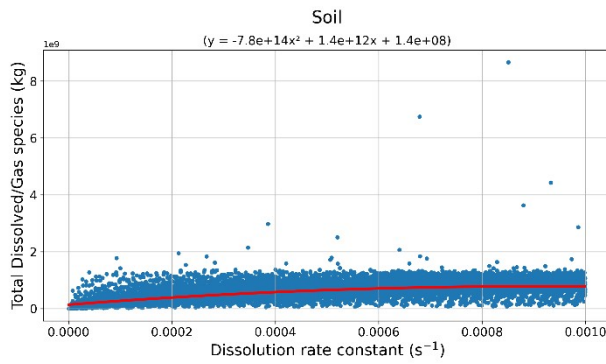

236

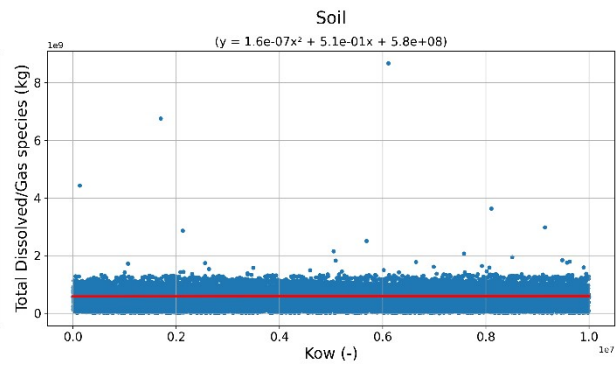
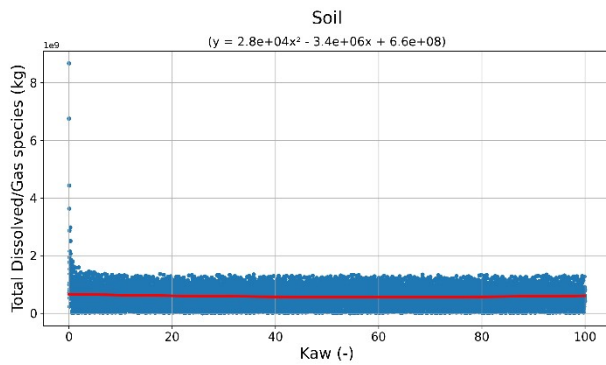

237

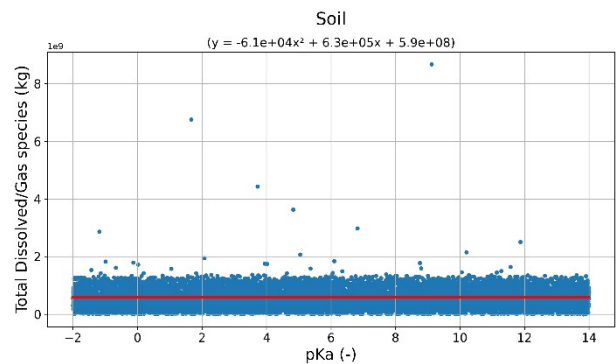
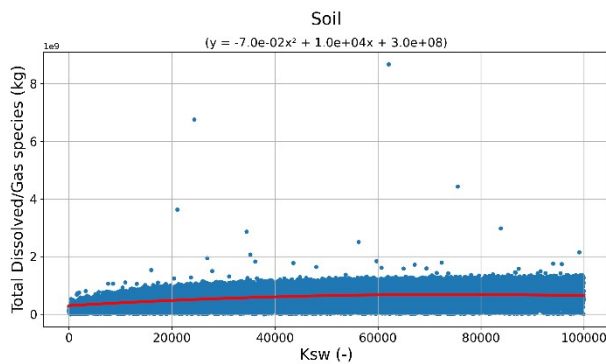

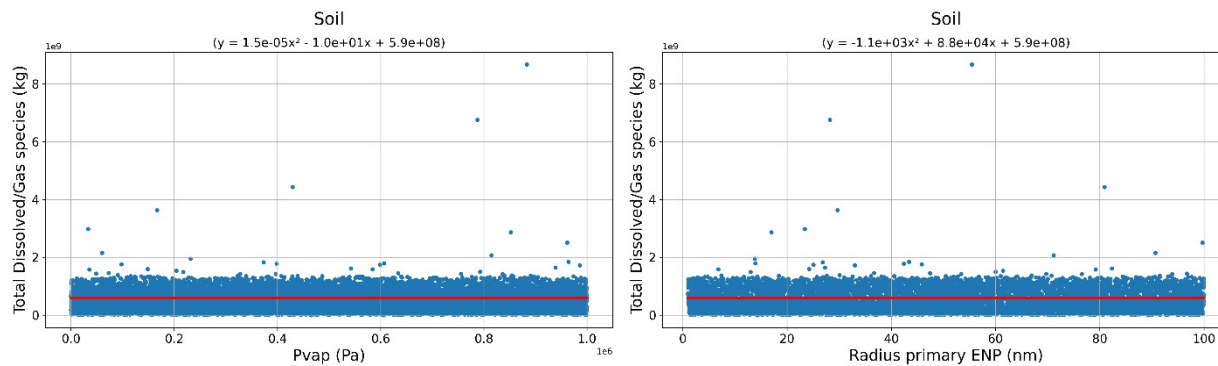

238

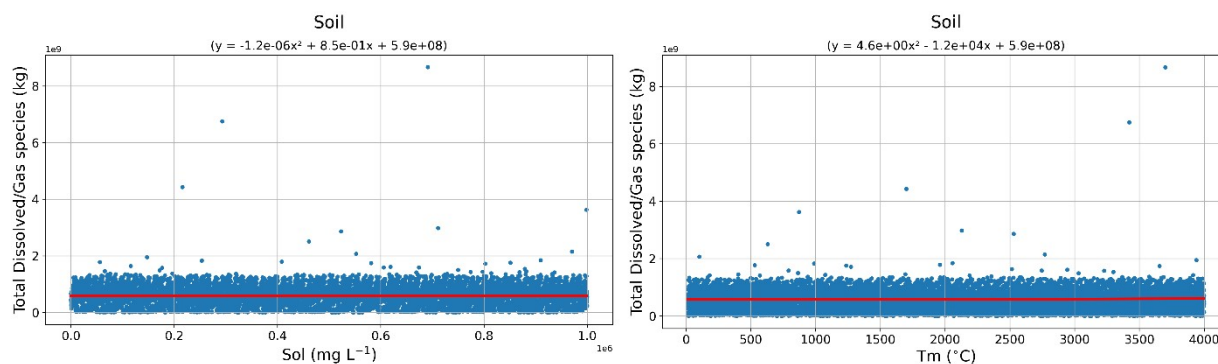

239

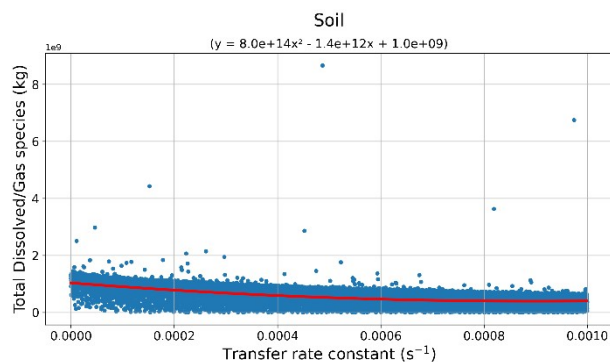

240

241 **Figure S22.** Scatter plots of the 10,000 simulation outputs generated with the *SimpleBox4nano* web application for the
 242 dissolved/gas species (D-species) under the solid-species emission scenario (1000 t y^{-1}) to the soil compartment at the moderate
 243 (global-scale) zone. Each panel corresponds to one of the 13 physicochemical parameters (x-axis), plotted against the resulting
 244 total dissolved/gas mass (kg) at steady state (y-axis). Fitted second-order polynomial curves are included in each panel to provide
 245 an initial visual indication of non-linear trends.

246

247 **S10.1.2.2 Total Solid species**

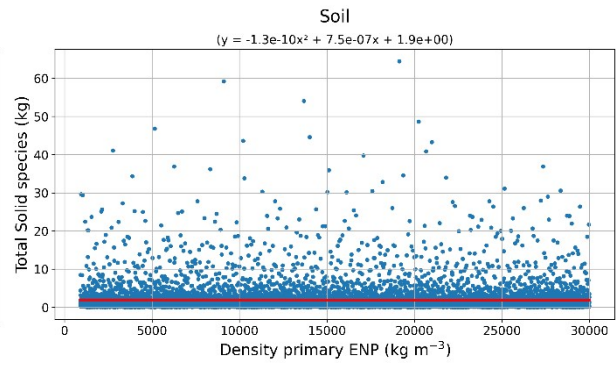
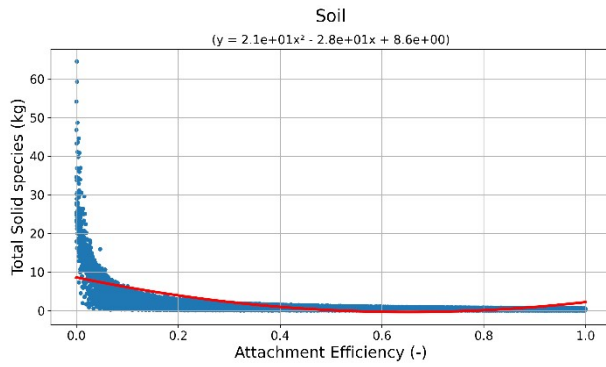

248

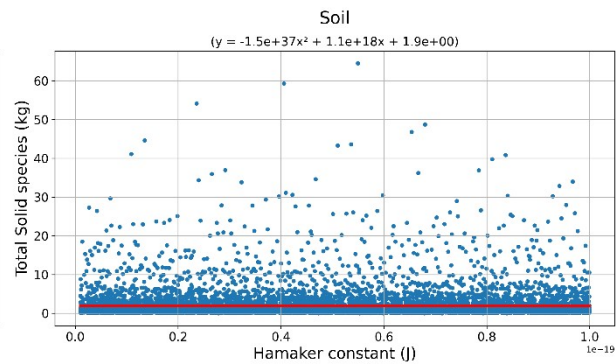
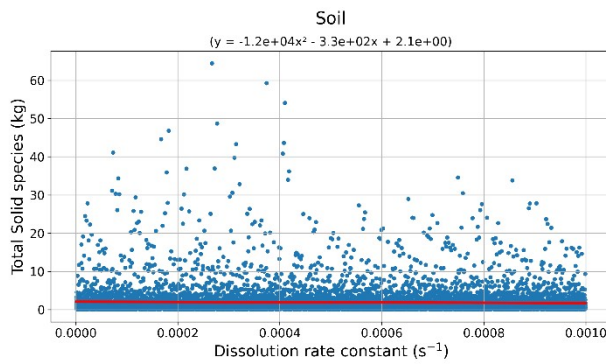

249

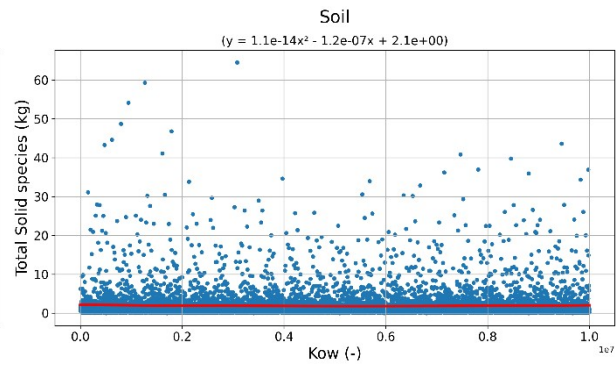
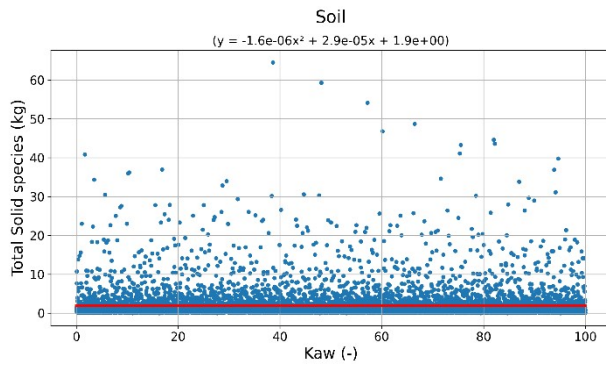

250

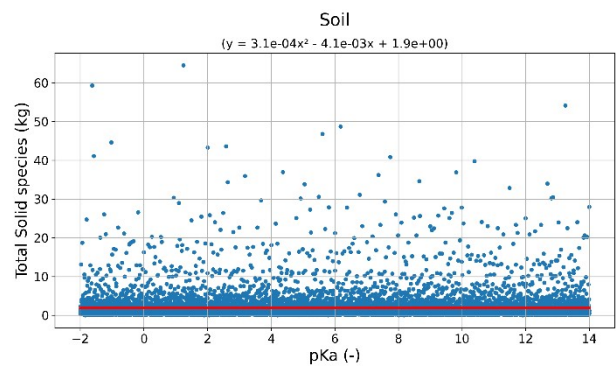
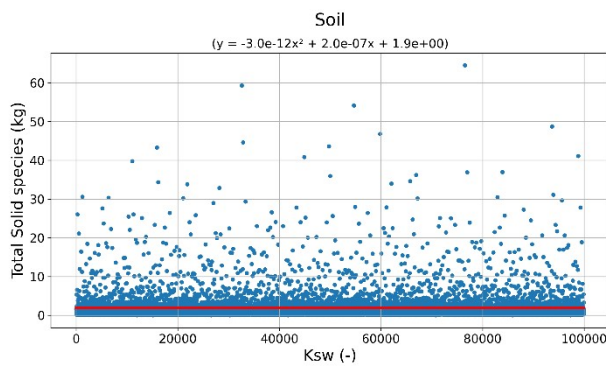

251

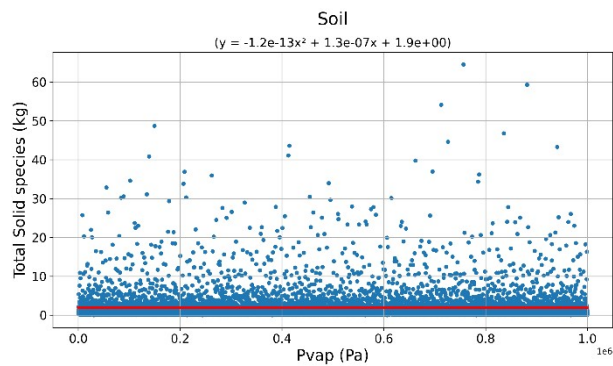

252

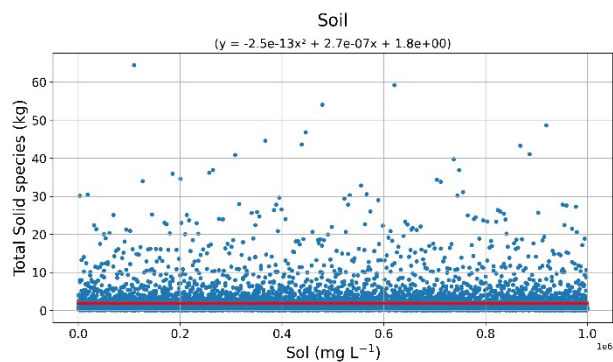
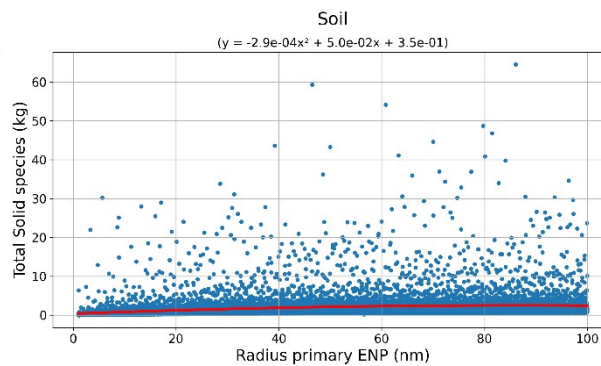

253

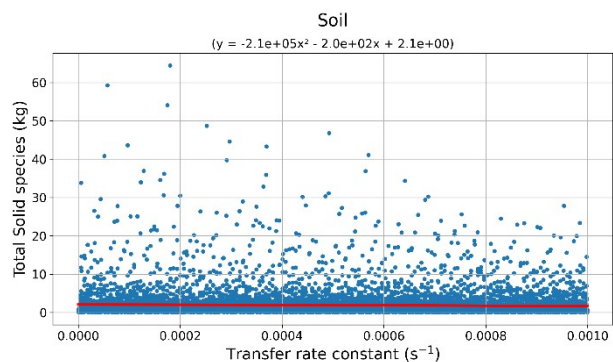
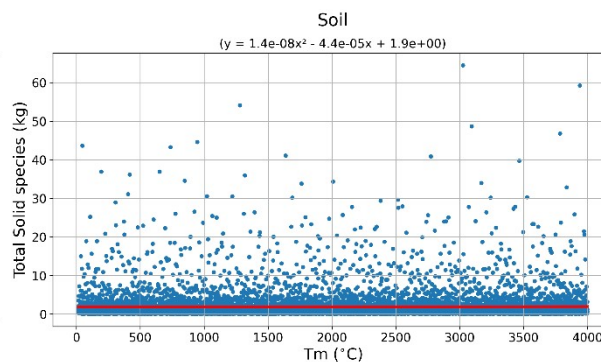

254

255 **Figure S23.** Scatter plots of the 10,000 simulation outputs generated with the *SimpleBox4nano* web application for the solid
 256 species (S-species) under the solid-species emission scenario (1000 t y^{-1}) to the soil compartment at the moderate (global-scale)
 257 zone. Each panel corresponds to one of the 13 physicochemical parameters (x-axis), plotted against the resulting total
 258 dissolved/gas mass (kg) at steady state (y-axis). Fitted second-order polynomial curves are included in each panel to provide an
 259 initial visual indication of non-linear trends.

260

261 **S10.1.2.3 Total species attached to NCs (< 450 nm)**

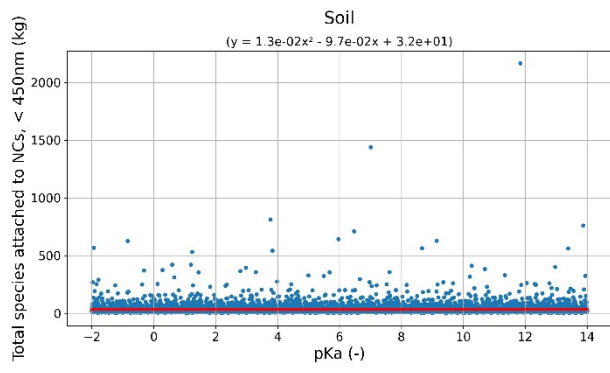
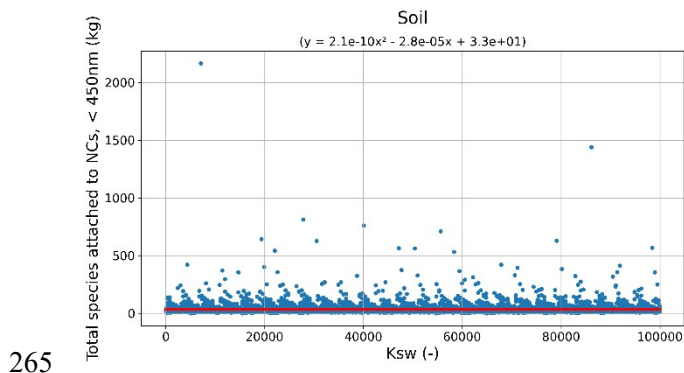
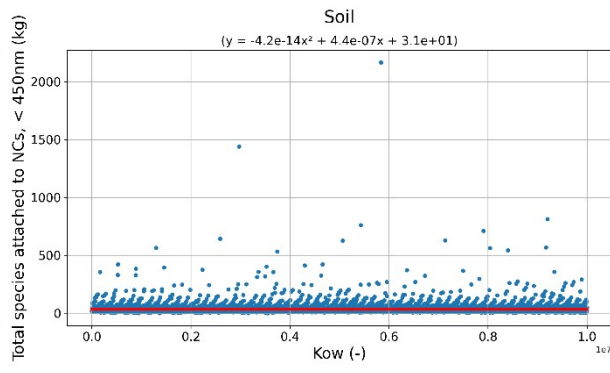
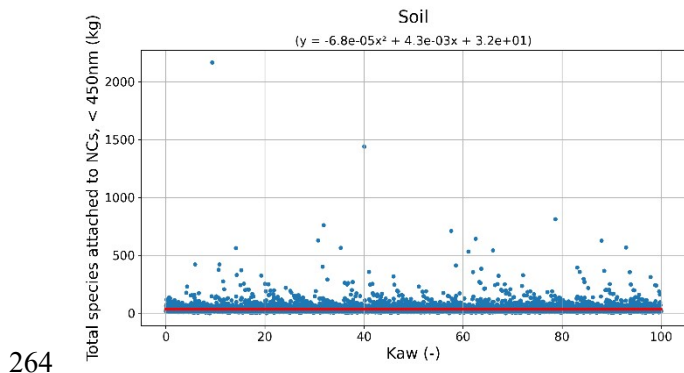
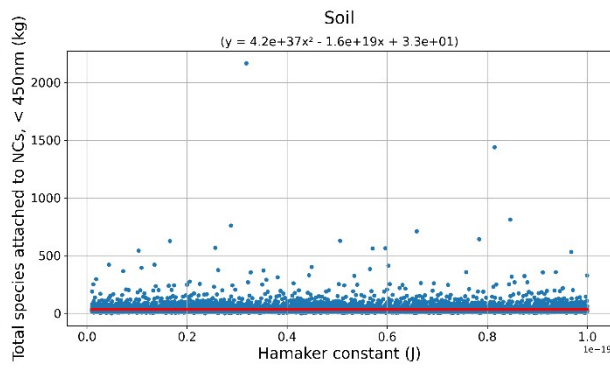
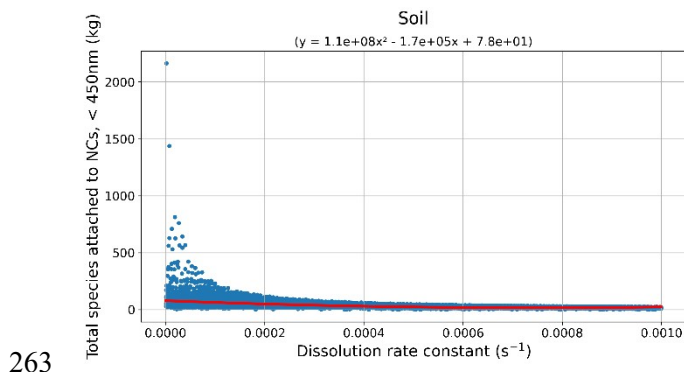
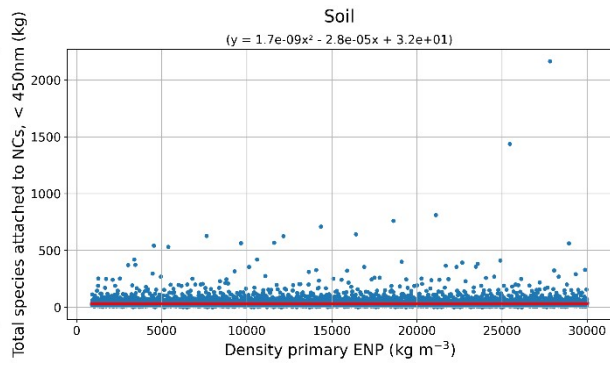
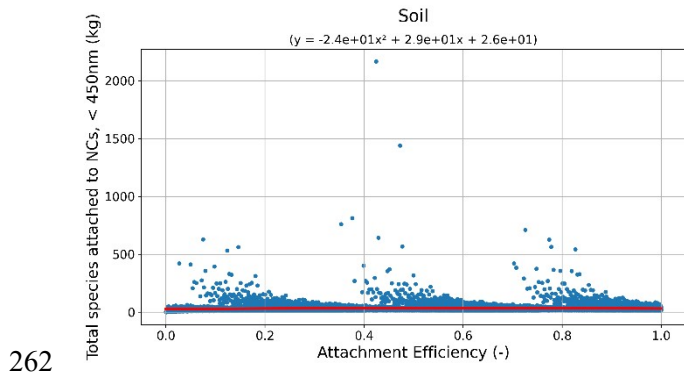

266

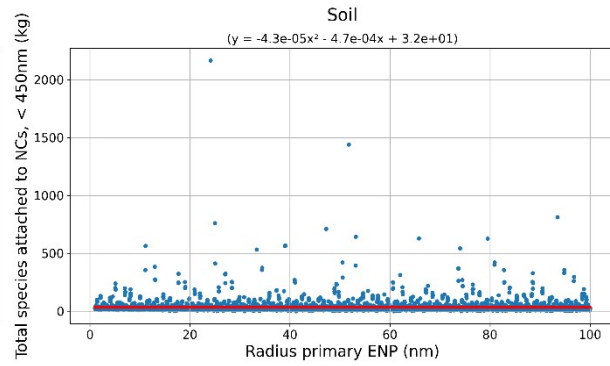
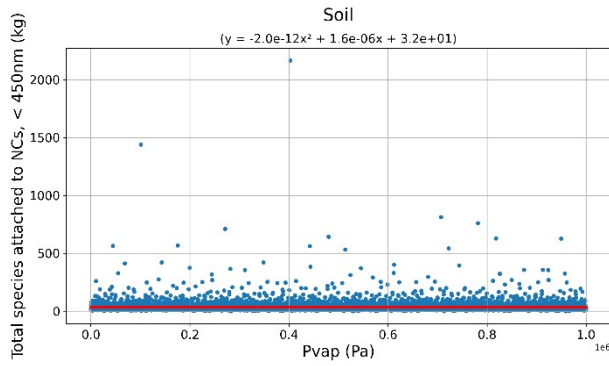

267

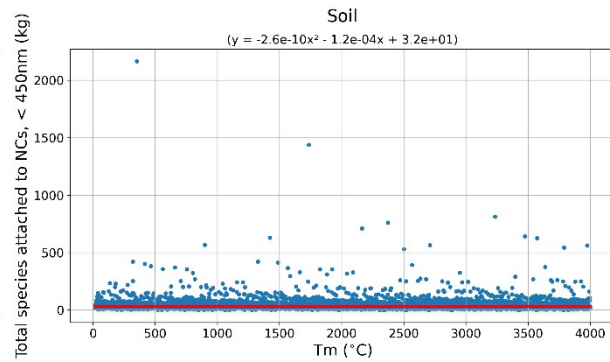
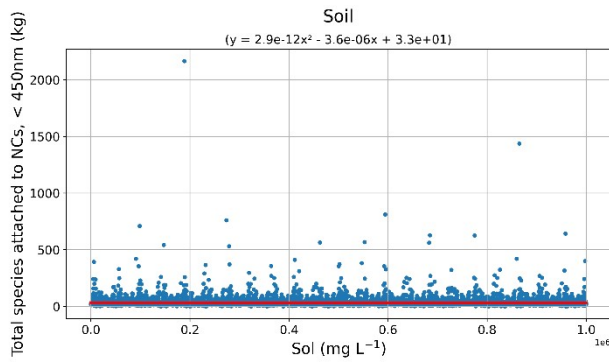

268

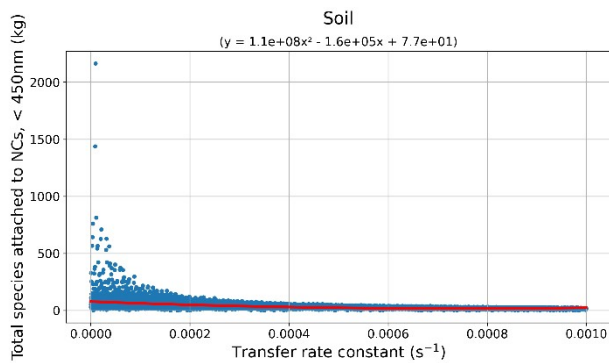

269

270

271

272

273

Figure S24. Scatter plots of the 10,000 simulation outputs generated with the *SimpleBox4nano* web application for the hetero-aggregated species attached to natural colloids (< 450 nm) (A) under the solid-species emission scenario (1000 t y⁻¹) to the soil compartment at the moderate (global-scale) zone. Each panel corresponds to one of the 13 physicochemical parameters (x-axis), plotted against the resulting total dissolved/gas mass (kg) at steady state (y-axis). Fitted second-order polynomial curves are included in each panel to provide an initial visual indication of non-linear trends.

274

275 **S10.1.2.4 Total species attached to suspended particles (> 450 nm)**

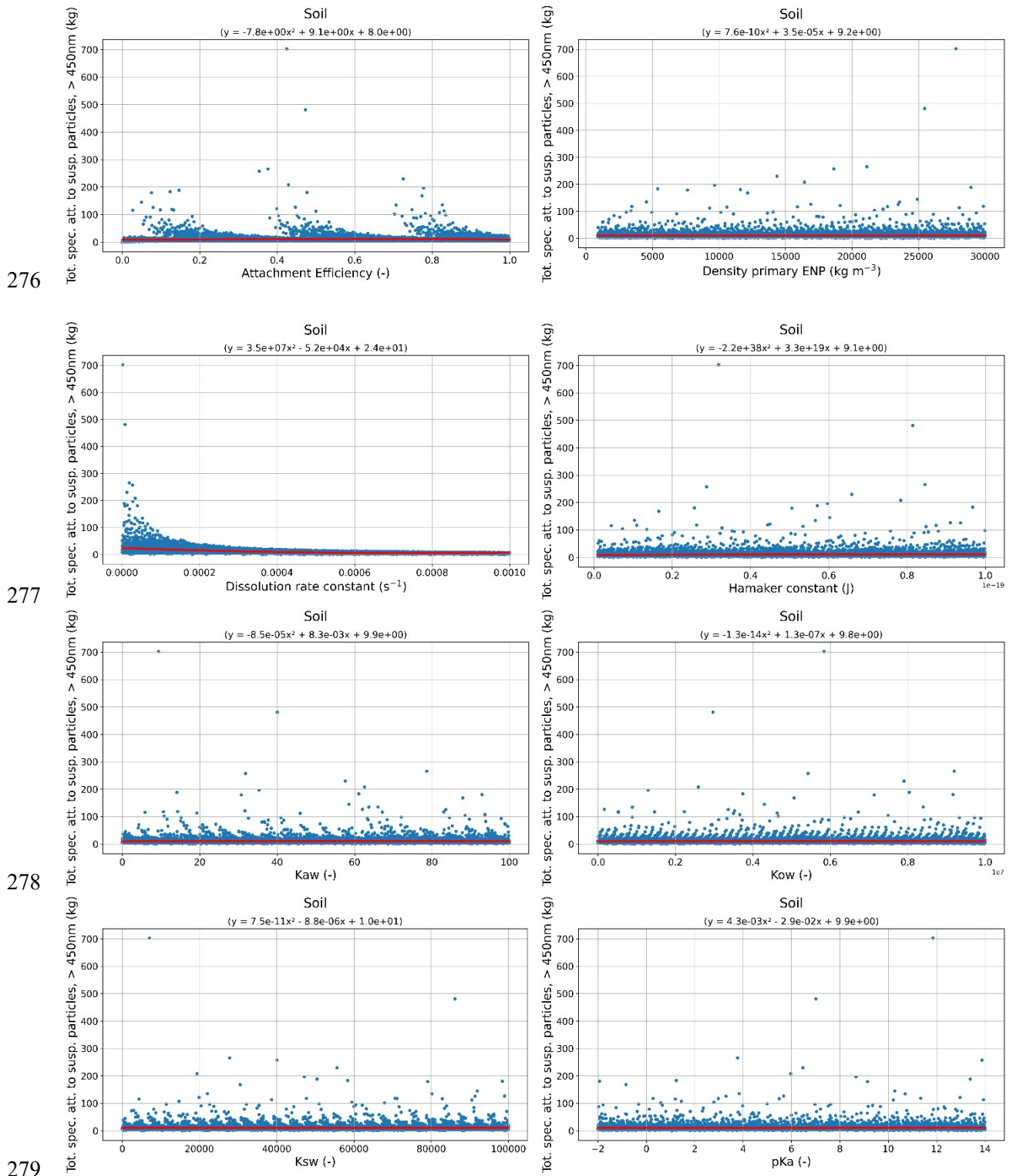

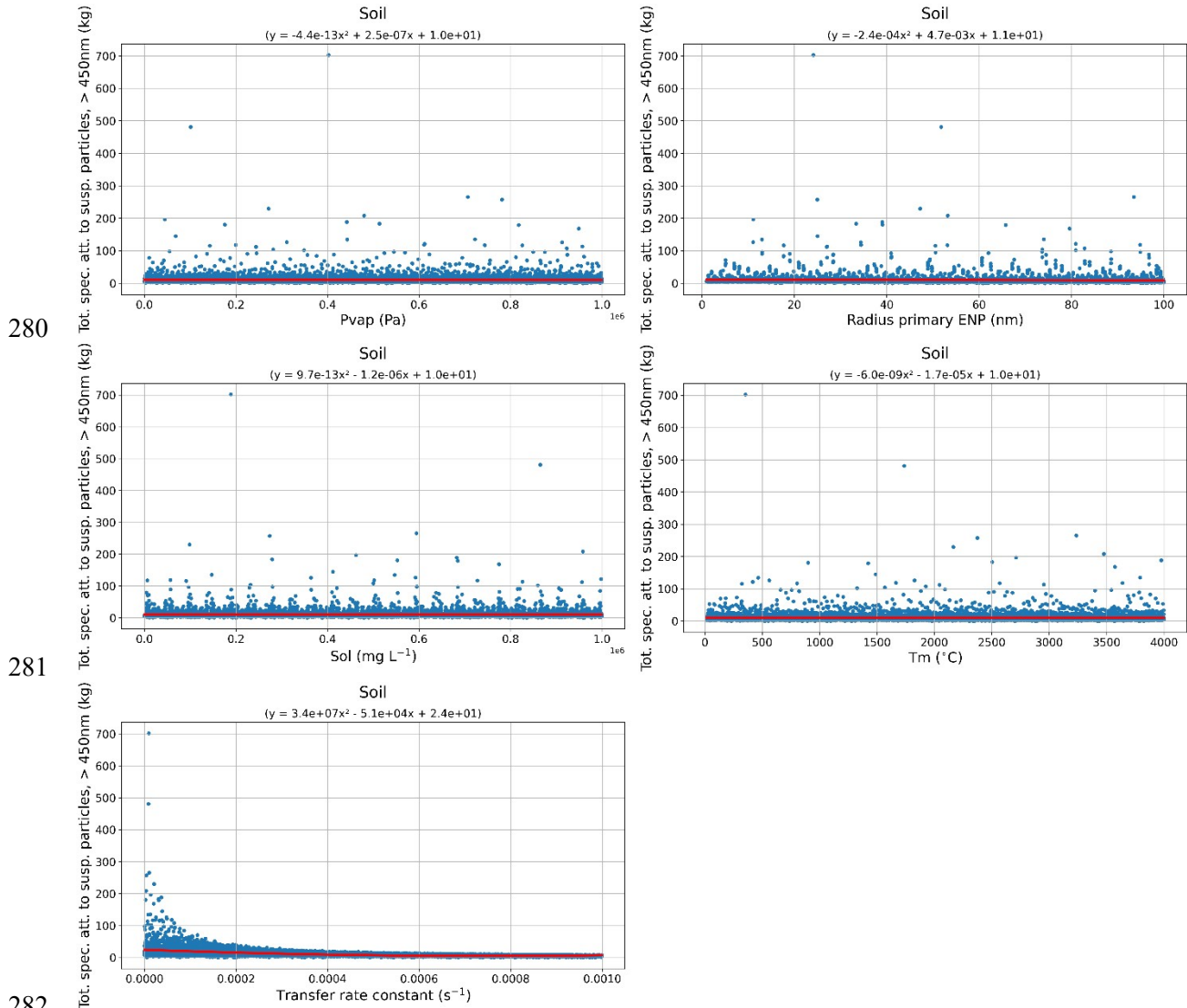

283 **Figure S25.** Scatter plots of the 10,000 simulation outputs generated with the *SimpleBox4nano* web application for the species
 284 attached to suspended particles (> 450 nm) (P) under the solid-species emission scenario (1000 t y^{-1}) to the soil compartment at
 285 the moderate (global-scale) zone. Each panel corresponds to one of the 13 physicochemical parameters (x-axis), plotted against
 286 the resulting total dissolved/gas mass (kg) at steady state (y-axis). Fitted second-order polynomial curves are included in each
 287 panel to provide an initial visual indication of non-linear trends.

288

289 S10.1.3 Water

290 S10.1.3.1 Dissolved/Gas species

291

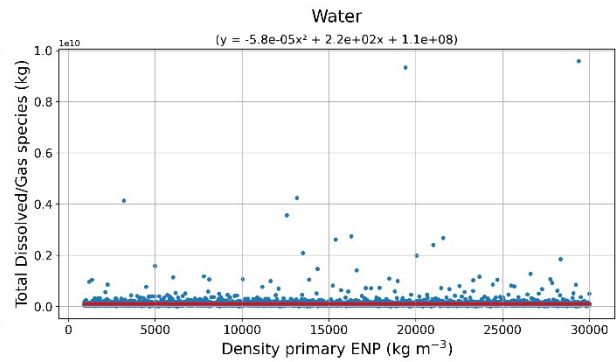
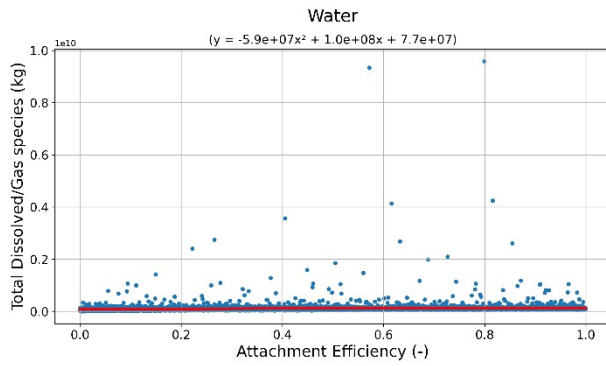

292

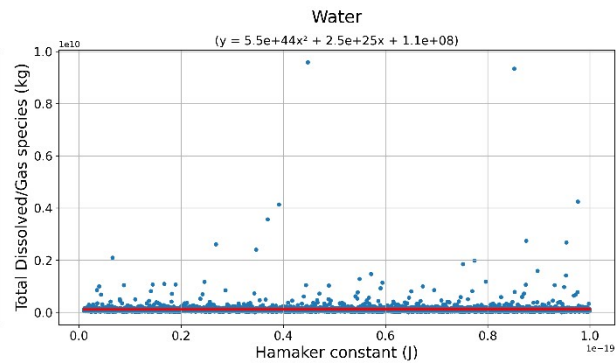
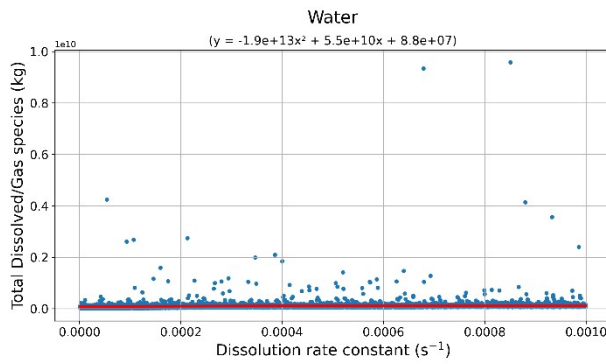

293

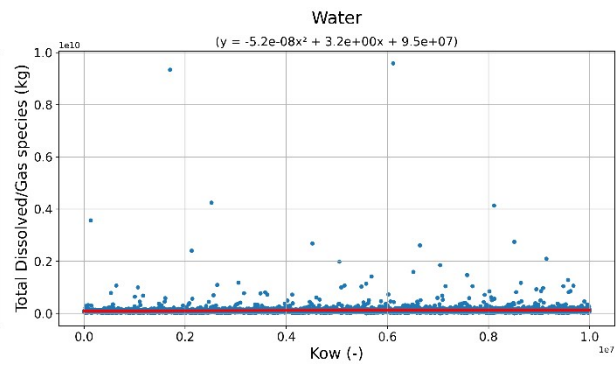
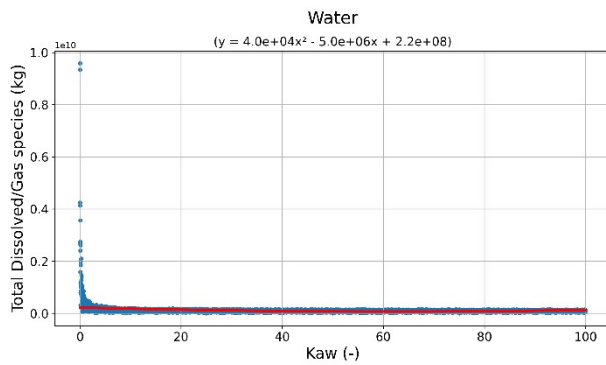

294

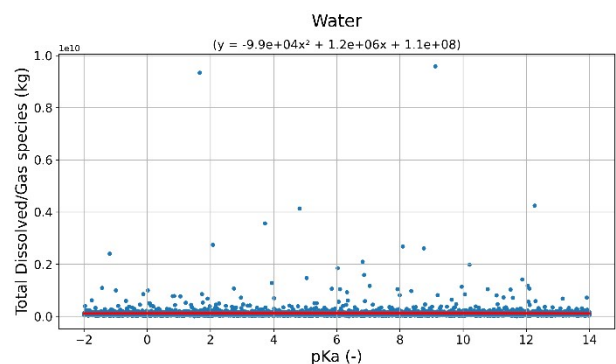
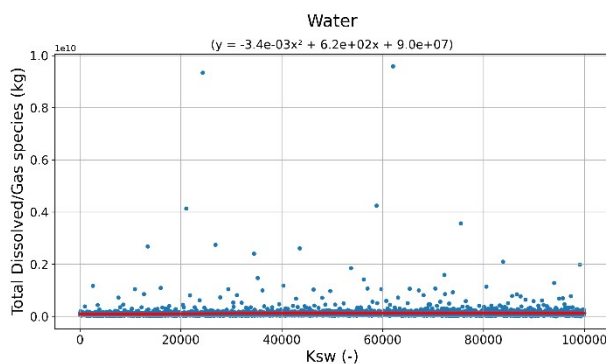

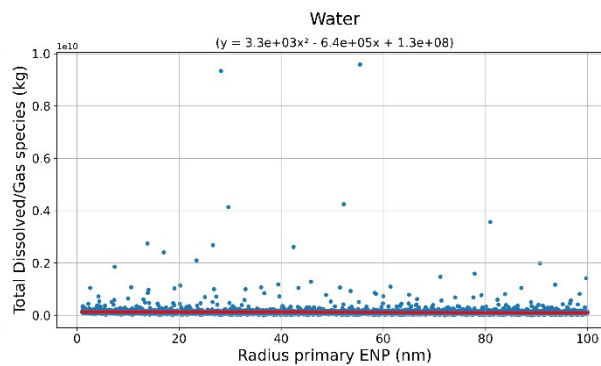
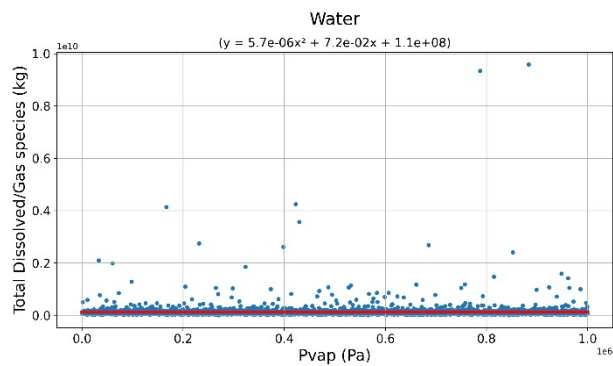

295

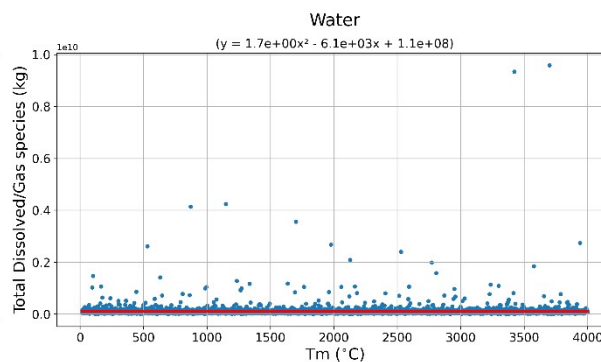
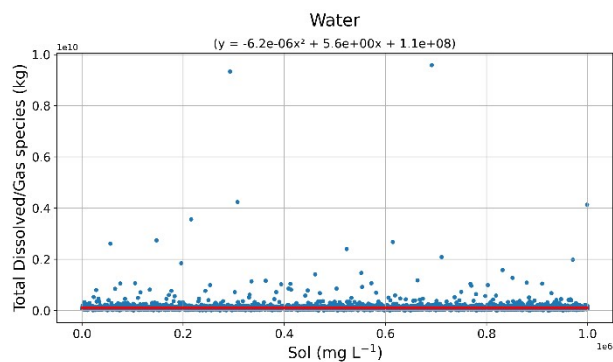

296

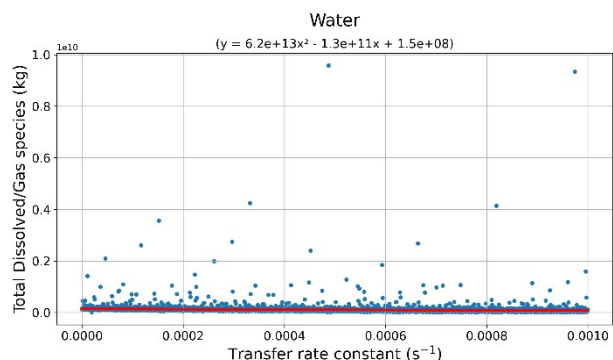

297

298 **Figure S26.** Scatter plots of the 10,000 simulation outputs generated with the *SimpleBox4nano* web application for the
 299 dissolved/gas species (D-species) under the solid-species emission scenario (1000 t y^{-1}) to the water compartment at the moderate
 300 (global-scale) zone. Each panel corresponds to one of the 13 physicochemical parameters (x-axis), plotted against the resulting
 301 total dissolved/gas mass (kg) at steady state (y-axis). Fitted second-order polynomial curves are included in each panel to provide
 302 an initial visual indication of non-linear trends.

303

304 **S10.1.3.2 Total Solid species**

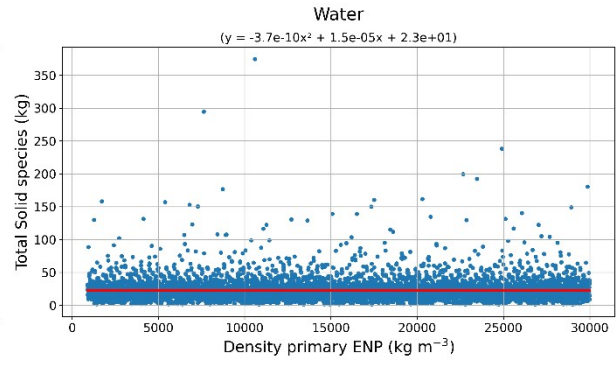
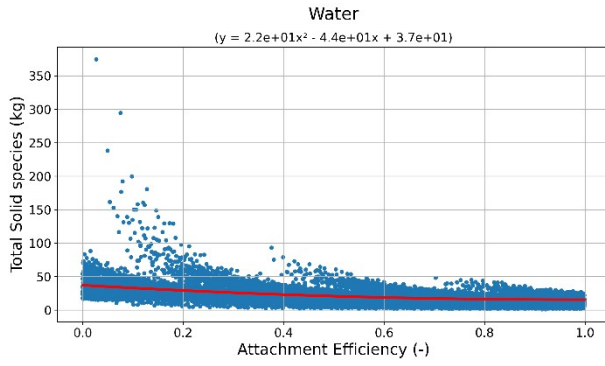

305

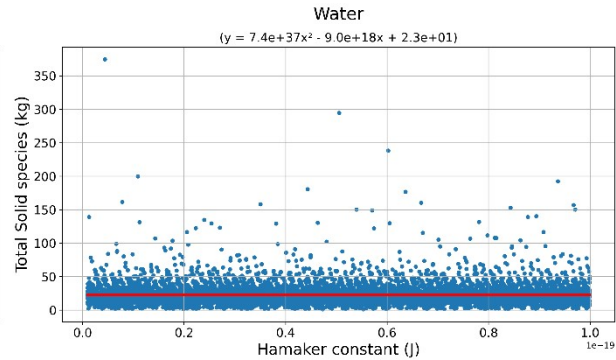
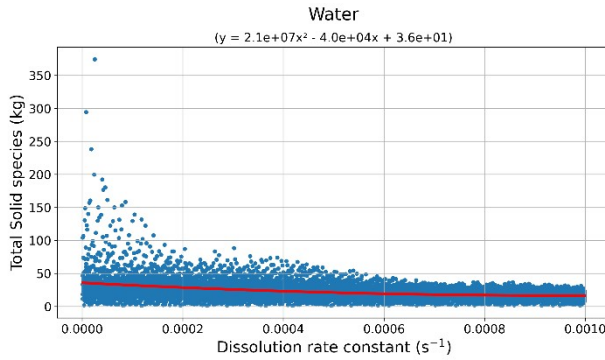

306

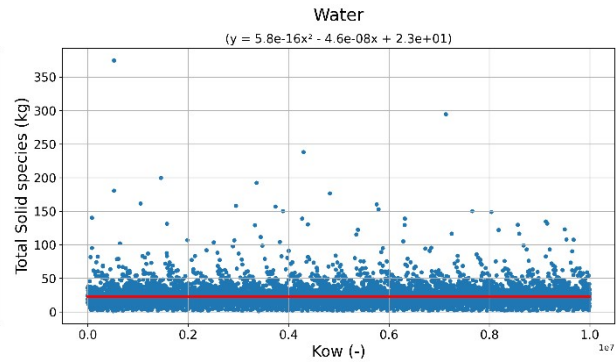
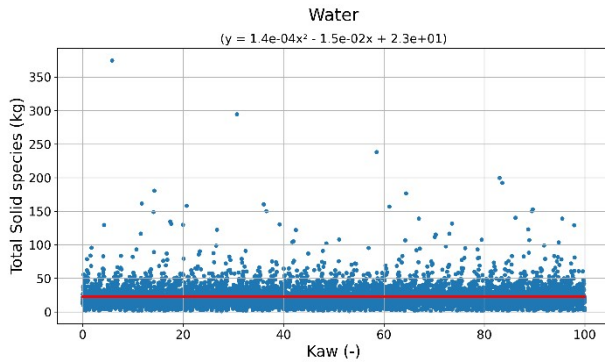

307

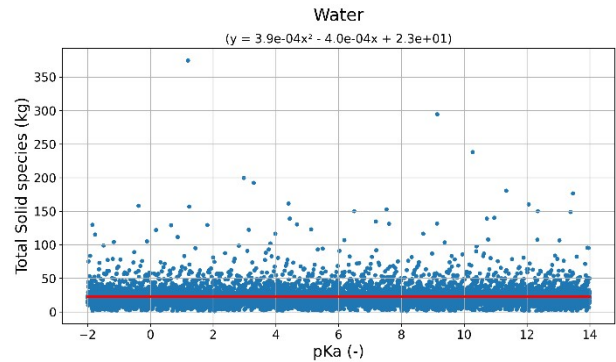
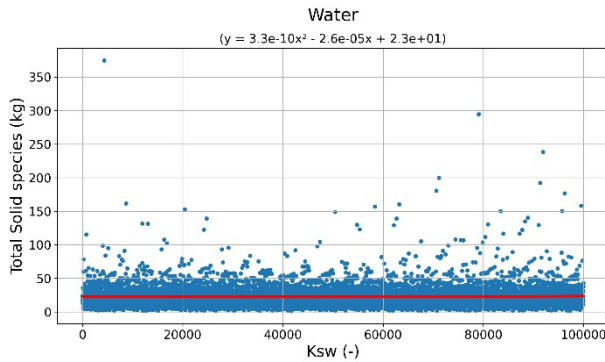

308

309

310

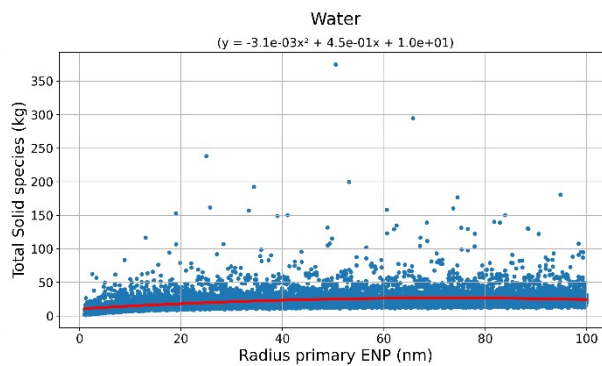
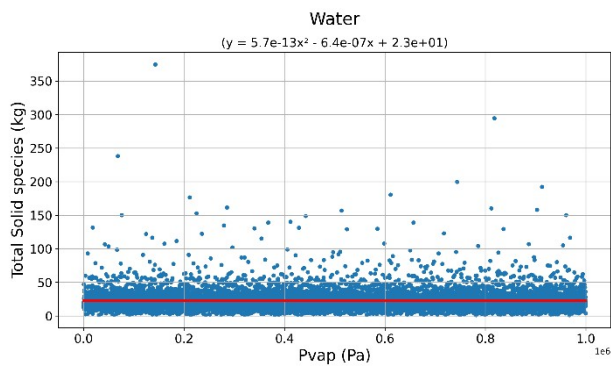

311

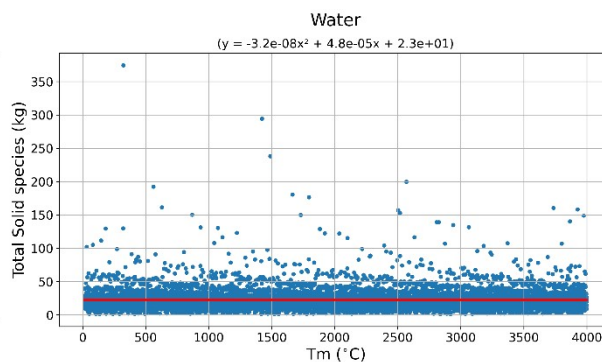
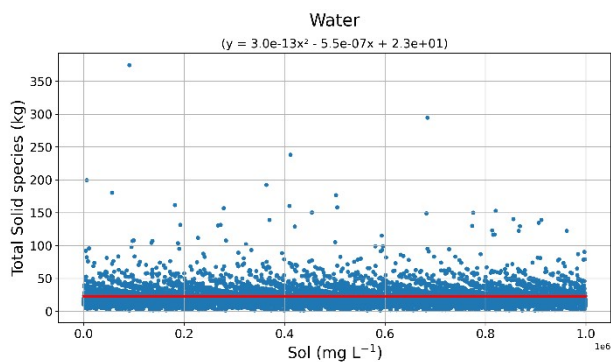

312

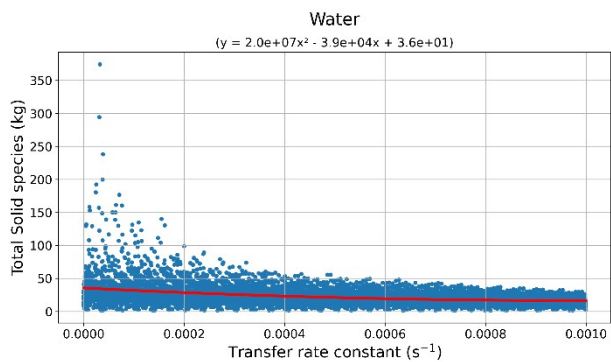

313

314 **Figure S27.** Scatter plots of the 10,000 simulation outputs generated with the *SimpleBox4nano* web application for the solid
 315 species (S-species) under the solid-species emission scenario (1000 t y⁻¹) to the water compartment at the moderate (global-scale)
 316 zone. Each panel corresponds to one of the 13 physicochemical parameters (x-axis), plotted against the resulting total
 317 dissolved/gas mass (kg) at steady state (y-axis). Fitted second-order polynomial curves are included in each panel to provide an
 318 initial visual indication of non-linear trends.

319

320 **S10.1.3.3 Total species attached to NCs (< 450 nm)**

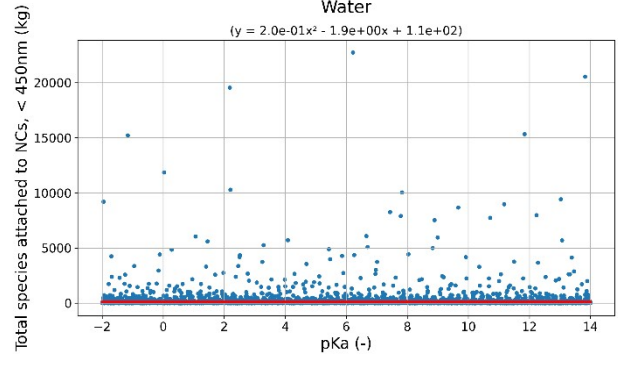
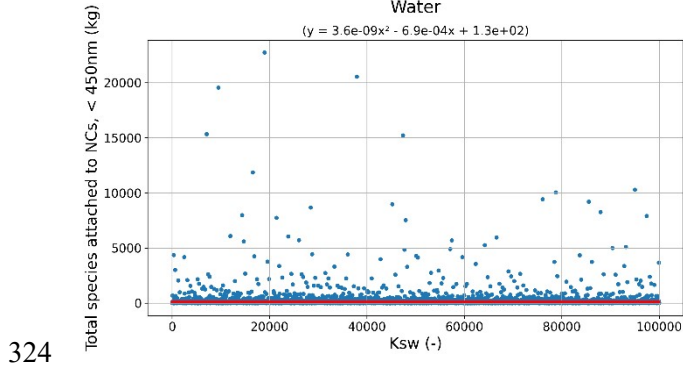
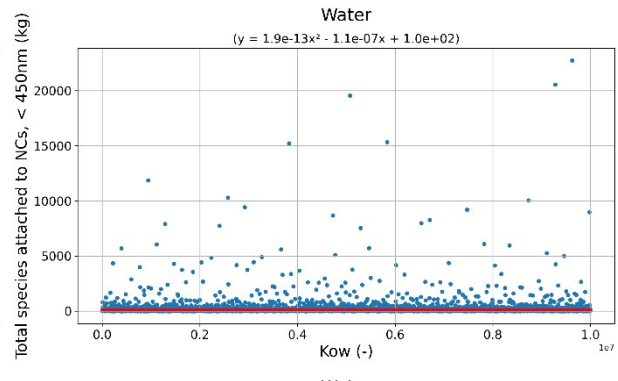
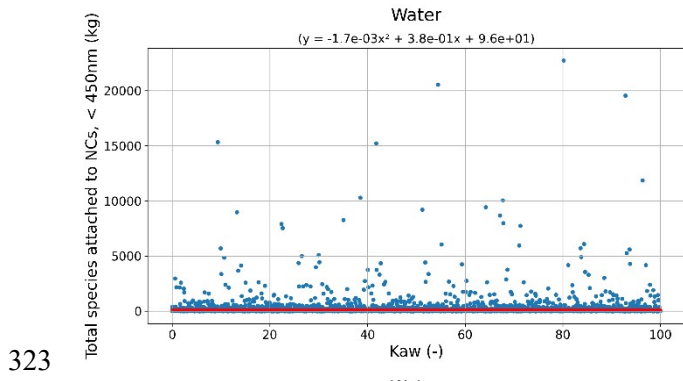
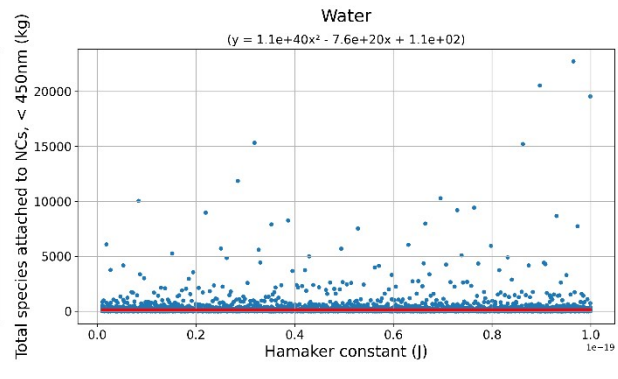
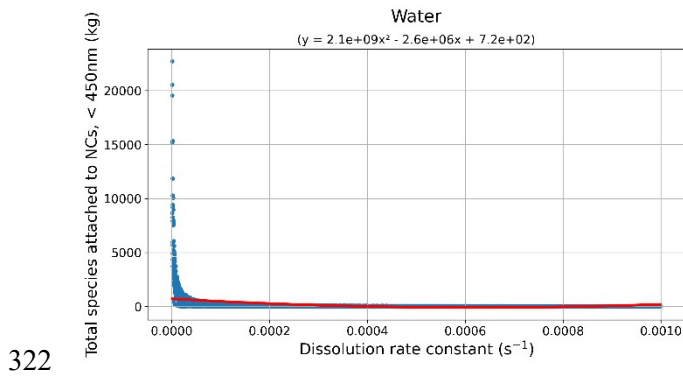
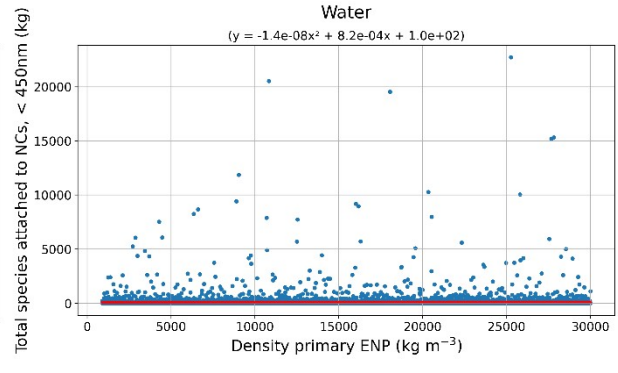
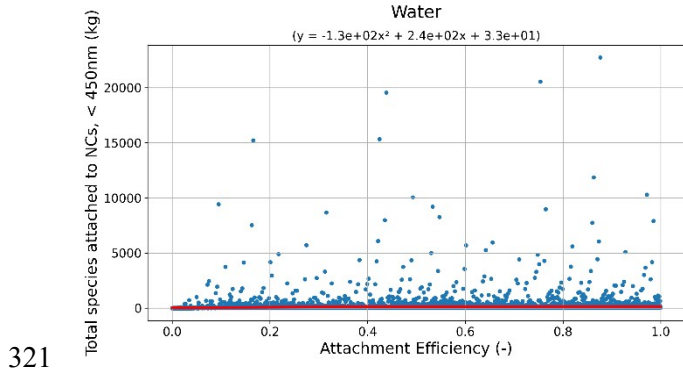

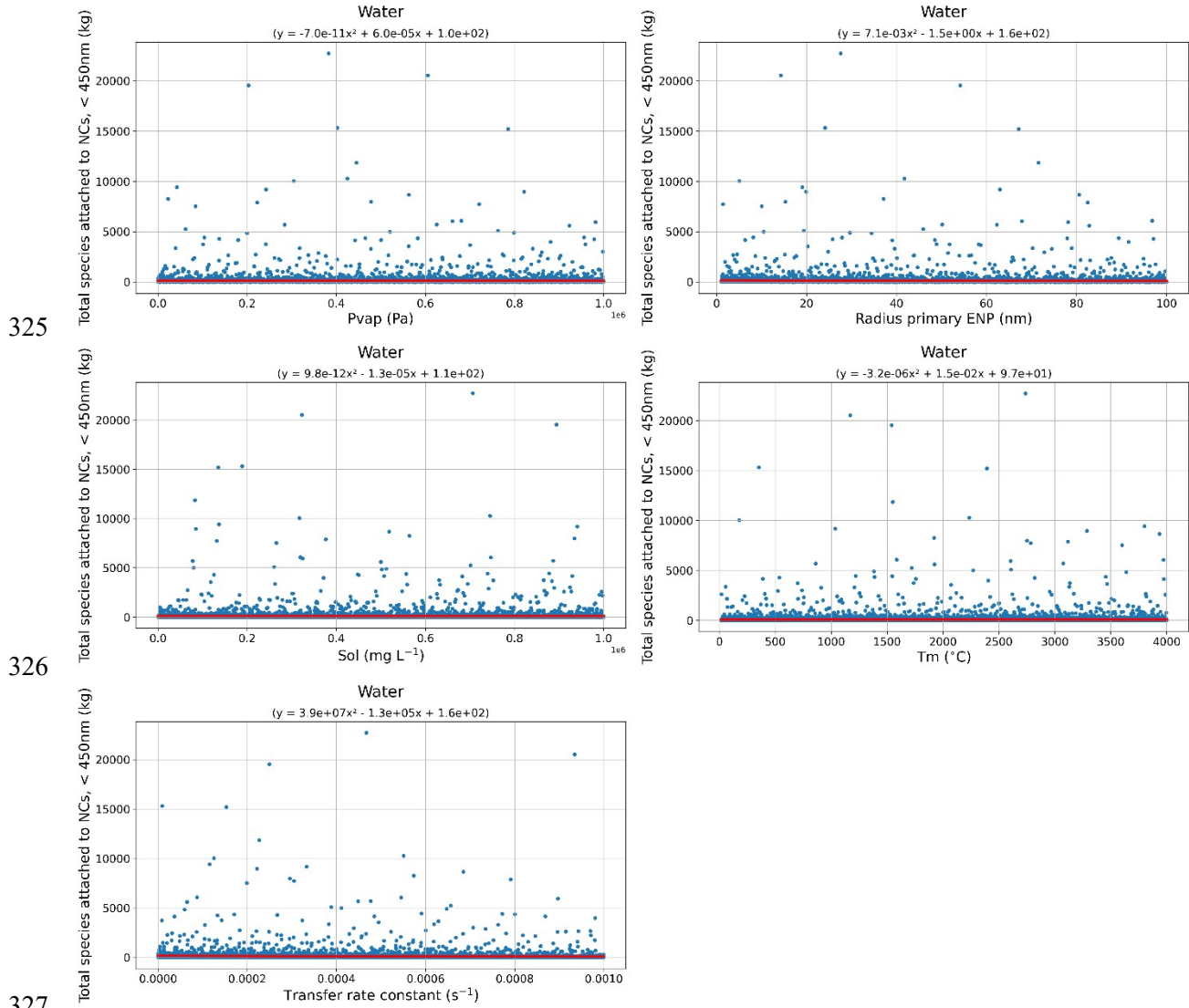

328 **Figure S28.** Scatter plots of the 10,000 simulation outputs generated with the *SimpleBox4nano* web application for the hetero-
 329 aggregated species attached to natural colloids (< 450 nm) (A) under the solid-species emission scenario (1000 t y^{-1}) to the water
 330 compartment at the moderate (global-scale) zone. Each panel corresponds to one of the 13 physicochemical parameters (x-axis),
 331 plotted against the resulting total dissolved/gas mass (kg) at steady state (y-axis). Fitted second-order polynomial curves are
 332 included in each panel to provide an initial visual indication of non-linear trends.

333

334 **S10.1.3.4 Total species attached to suspended particles (> 450 nm)**

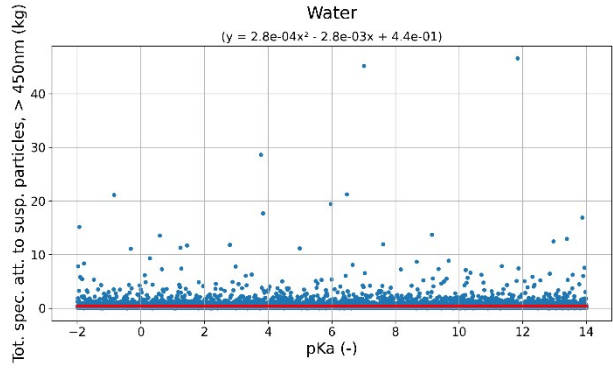
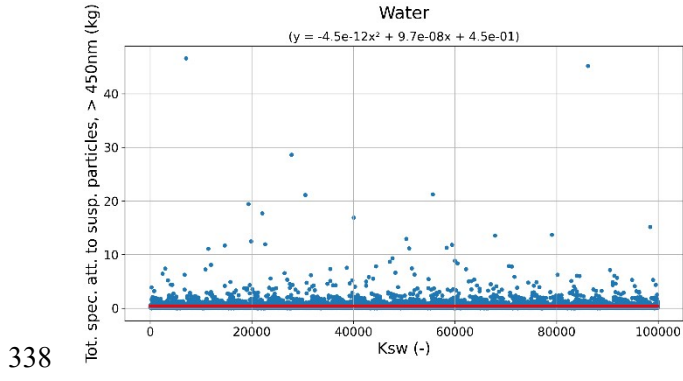
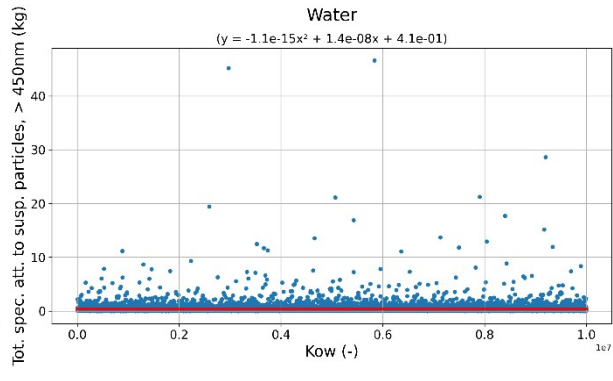
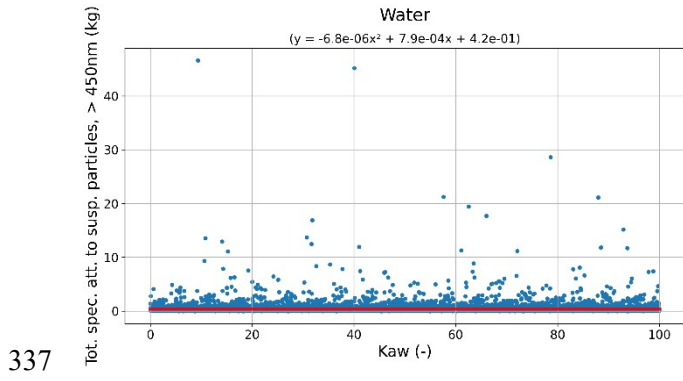
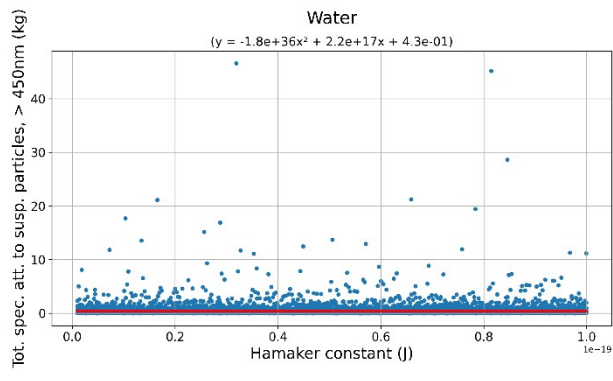
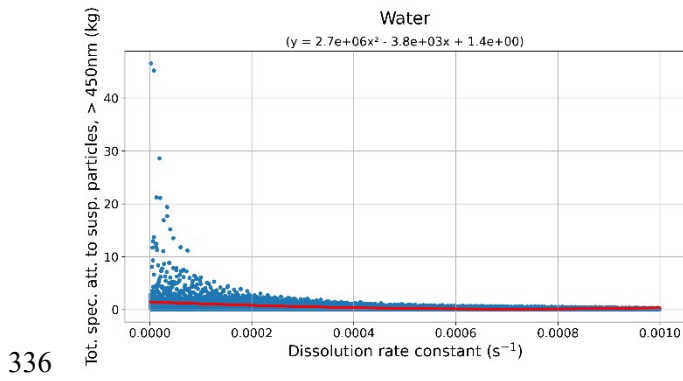
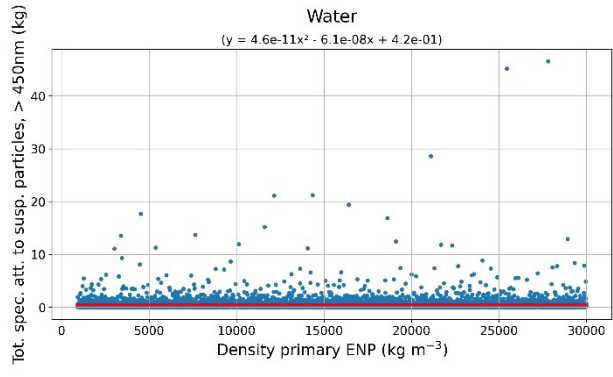
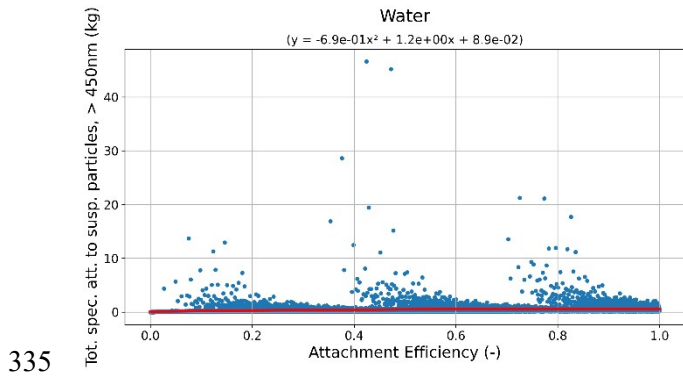

339

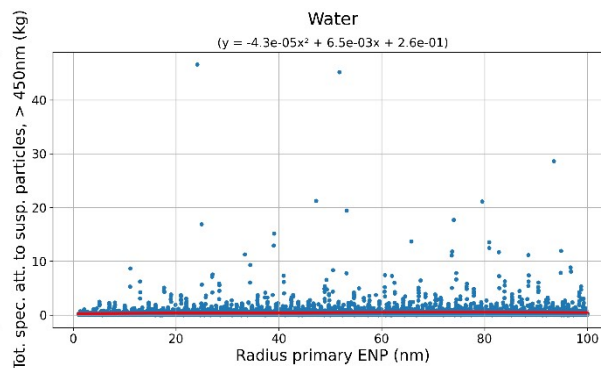
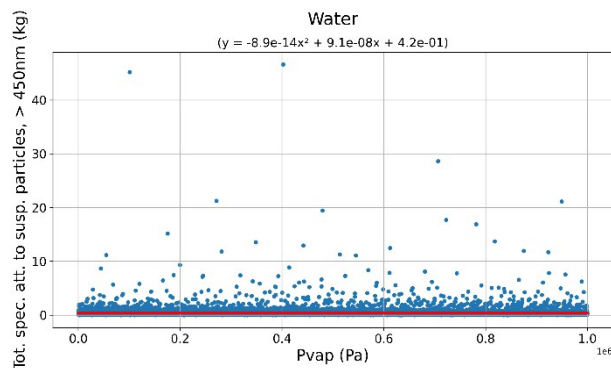

340

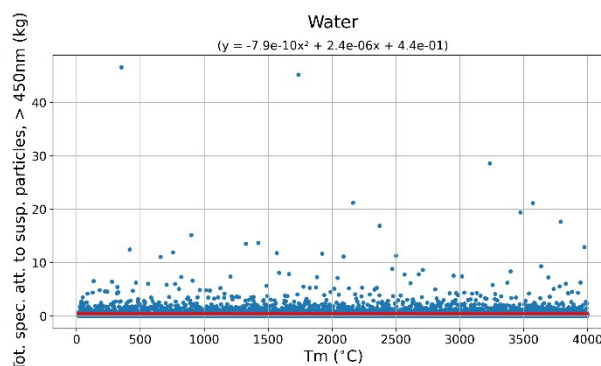
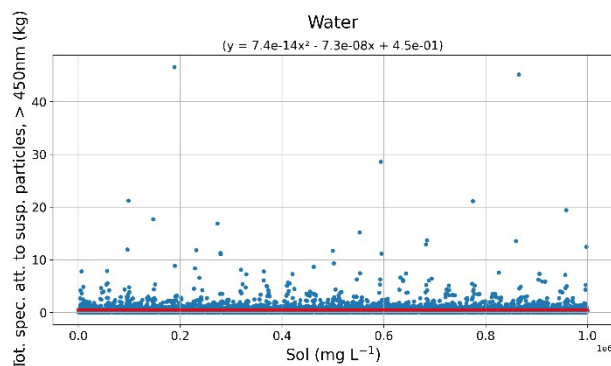

341

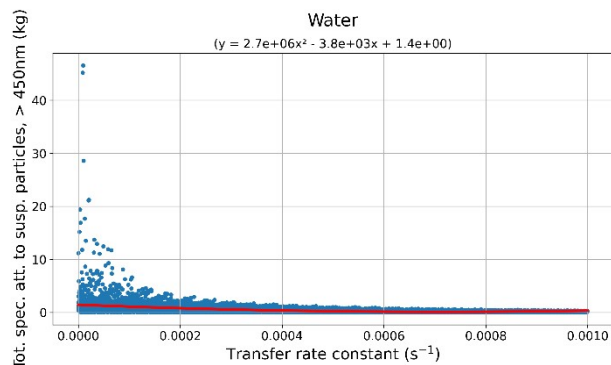

342

Figure S29. Scatter plots of the 10,000 simulation outputs generated with the *SimpleBox4nano* web application for the species attached to suspended particles (> 450 nm) (P) under the solid-species emission scenario (1000 t y⁻¹) to the water compartment at the moderate (global-scale) zone. Each panel corresponds to one of the 13 physicochemical parameters (x-axis), plotted against the resulting total dissolved/gas mass (kg) at steady state (y-axis). Fitted second-order polynomial curves are included in each panel to provide an initial visual indication of non-linear trends.

347

348 **S11. Pareto analysis for D species under three different emission scenarios**

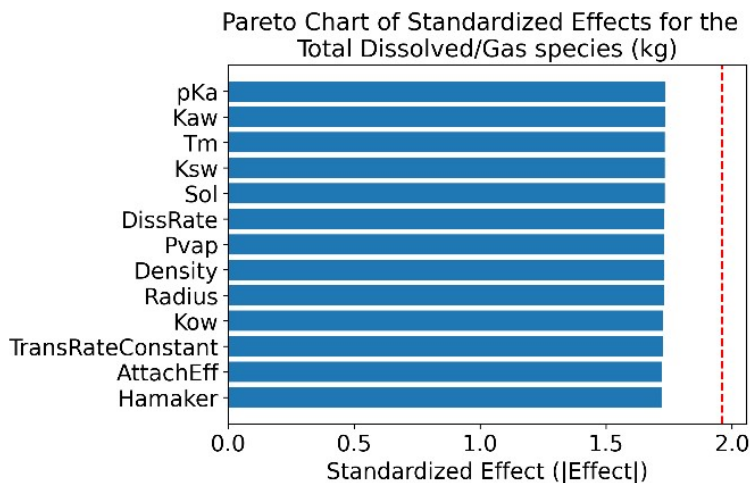

349

350 **Figure S30.** Pareto chart of standardized main effects for the total dissolved/gas species (D-species) mass output, as generated
 351 with the *SimpleBox4nano* web application under the solid-species emission scenario to the air compartment at the moderate
 352 (global-scale) zone. Horizontal bars indicate the magnitude and direction of each standardized main effect for the 13
 353 physicochemical parameters. The vertical dotted red line denotes the statistical significance threshold ($\alpha = 0.05$), above which
 354 parameter effects are considered statistically significant.

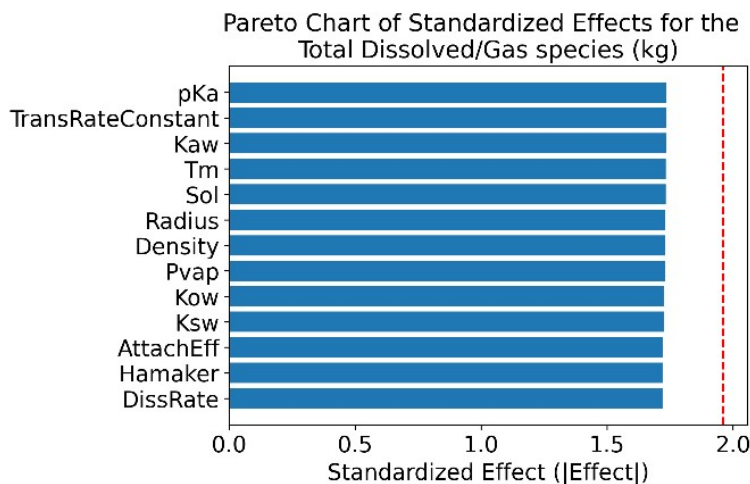

355

356 **Figure S31.** Pareto chart of standardized main effects for the total dissolved/gas species (D-species) mass output, as generated
 357 with the *SimpleBox4nano* web application under the solid-species emission scenario to the soil compartment at the moderate
 358 (global-scale) zone. Horizontal bars indicate the magnitude and direction of each standardized main effect for the 13
 359 physicochemical parameters. The vertical dotted red line denotes the statistical significance threshold ($\alpha = 0.05$), above which
 360 parameter effects are considered statistically significant.

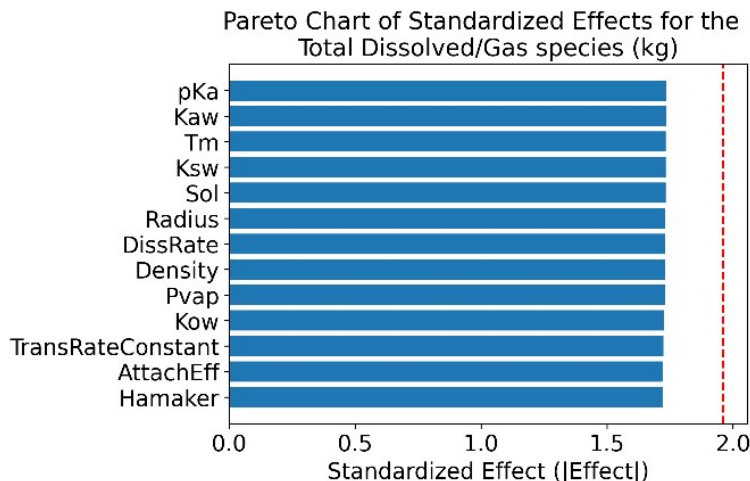

361

362 **Figure S32.** Pareto chart of standardized main effects for the total dissolved/gas species (D-species) mass output, as generated
 363 with the *SimpleBox4nano* web application under the solid-species emission scenario to the water compartment at the moderate
 364 (global-scale) zone. Horizontal bars indicate the magnitude and direction of each standardized main effect for the 13
 365 physicochemical parameters. The vertical dotted red line denotes the statistical significance threshold ($\alpha = 0.05$), above which
 366 parameter effects are considered statistically significant.

367 **S12. Sensitivity Exploration**

368 **S12.1 Solid-species emissions (1000 t y⁻¹) in soil compartment of the moderate (global scale) zone**

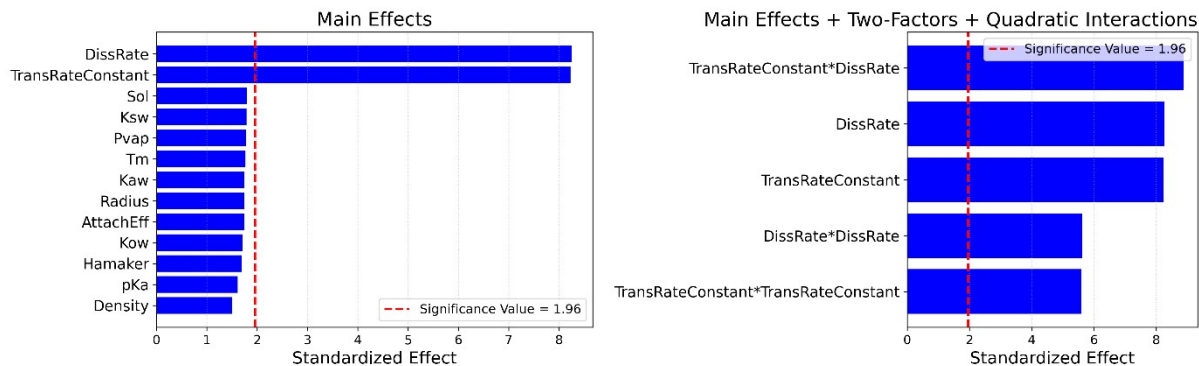

369

370 **Figure S33.** Pareto charts of standardized effects for the total solid-associated mass (S + A + P) under a solid-species emission of
 371 1000 t y⁻¹ in soil compartment of the moderate (global scale) zone. Left chart presents the main-effects Pareto chart for all 13
 372 physicochemical parameters. Right chart presents Pareto chart including main, two-factor interaction, and quadratic terms for the
 373 three influential properties observed in the left chart. The vertical red dashed line denotes in both charts the statistical significance
 374 threshold.

375

376 **S12.2 Solid-species emissions (1000 t y⁻¹) in water compartment of the moderate (global scale) zone**

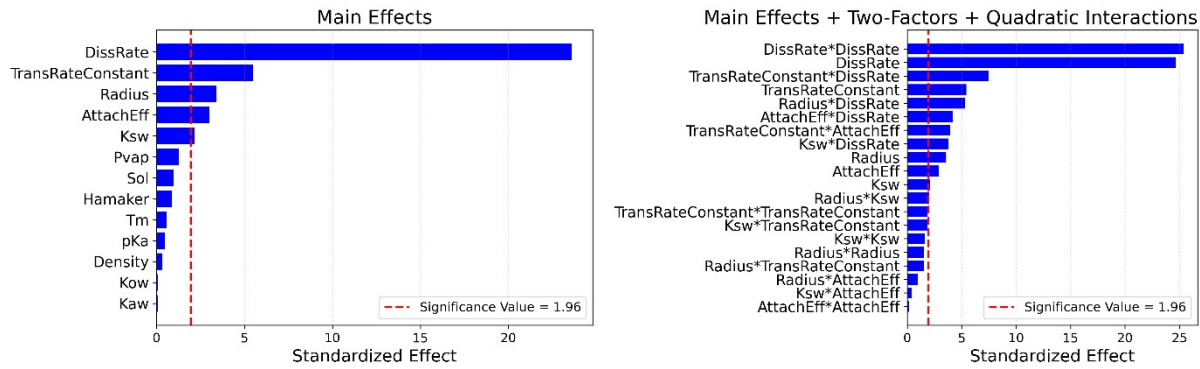

377

378 **Figure S34.** Pareto charts of standardized effects for the total solid-associated mass (S + A + P) under a solid-species emission of
 379 1000 t y⁻¹ in water compartment of the moderate (global scale) zone. Left chart presents the main-effects Pareto chart for all 13
 380 physicochemical parameters. Right chart presents Pareto chart including main, two-factor interaction, and quadratic terms for the
 381 three influential properties observed in the left chart. The vertical red dashed line denotes in both charts the statistical significance
 382 threshold.

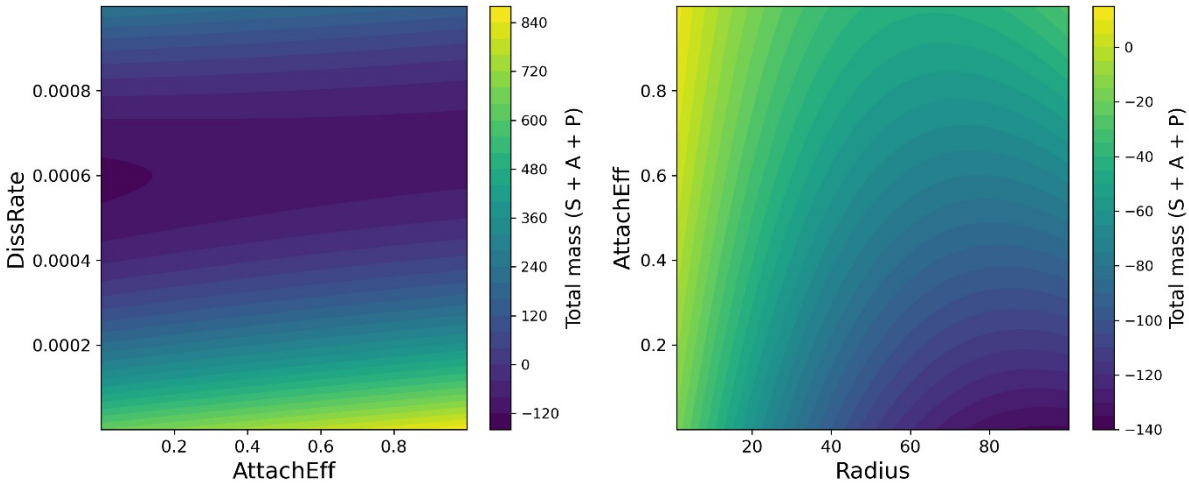

383

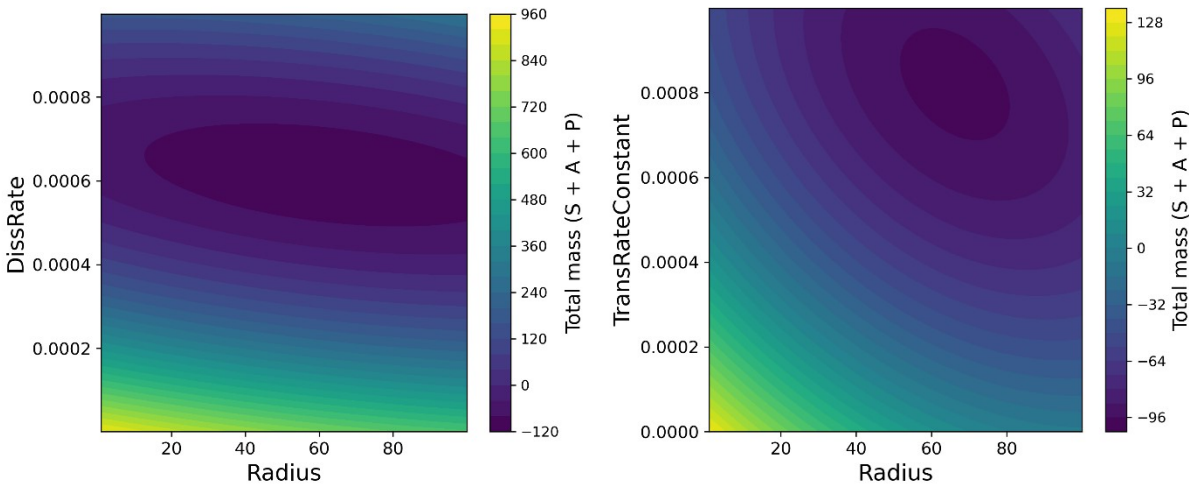

384

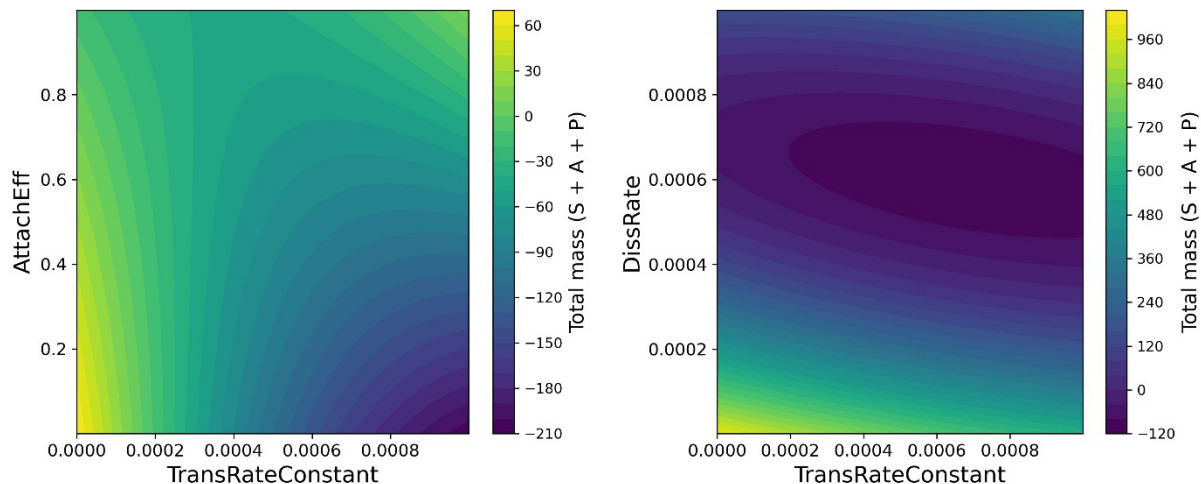

385

386 **Figure S35.** Two-factor response surfaces (heat maps) of the predicted total solid-associated mass (S + A + P) for the default
 387 engineered nanomaterial under a solid-species emission of $1000 \text{ t}\cdot\text{y}^{-1}$ to the water compartment of the moderate (global-scale)
 388 zone. The colour scale indicates the steady-state total mass of S + A + P (kg), with cooler colours corresponding to lower values.

389 References

- 390 (1) Baig, N.; Kammakam, I.; Falath, W. Nanomaterials: A review of synthesis methods, properties,
 391 recent progress, and challenges. *Materials advances* **2021**, *2* (6), 1821-1871.
- 392 (2) Tadjiki, S.; Montañó, M. D.; Assemi, S.; Barber, A.; Ranville, J.; Beckett, R. Measurement of the
 393 density of engineered silver nanoparticles using centrifugal FFF-TEM and single particle ICP-MS.
 394 *Analytical Chemistry* **2017**, *89* (11), 6056-6064.
- 395 (3) Widehammar, H. Molecular insight into ion interactions at charged interfaces exposing sulfonate
 396 headgroups. 2021.
- 397 (4) Morillas-Becerril, L.; Franco-Ulloa, S.; Fortunati, I.; Marotta, R.; Sun, X.; Zaroni, G.; De Vivo, M.;
 398 Mancin, F. Specific and nondisruptive interaction of guanidium-functionalized gold nanoparticles with
 399 neutral phospholipid bilayers. *Communications Chemistry* **2021**, *4* (1), 93.
- 400 (5) Cedillos-Barraza, O.; Manara, D.; Boboridis, K.; Watkins, T.; Grasso, S.; Jayaseelan, D. D.; Konings, R.
 401 J.; Reece, M. J.; Lee, W. E. Investigating the highest melting temperature materials: A laser melting study
 402 of the TaC-HfC system. *Scientific reports* **2016**, *6* (1), 37962.
- 403 (6) Florendo, M.; Figacz, A.; Srinageshwar, B.; Sharma, A.; Swanson, D.; Dunbar, G. L.; Rossignol, J. Use of
 404 polyamidoamine dendrimers in brain diseases. *Molecules* **2018**, *23* (9), 2238.
- 405 (7) Jafvert, C. T.; Kulkarni, P. P. Buckminsterfullerene's (C60) octanol- water partition coefficient (K_{ow})
 406 and aqueous solubility. *Environmental science & technology* **2008**, *42* (16), 5945-5950.
- 407 (8) Crandon, L. E.; Boenisch, K. M.; Harper, B. J.; Harper, S. L. Adaptive methodology to determine
 408 hydrophobicity of nanomaterials in situ. *PLoS One* **2020**, *15* (6), e0233844.
- 409 (9) Meesters, J.; Peijnenburg, W.; Hendriks, A.; Van de Meent, D.; Quik, J. A model sensitivity analysis to
 410 determine the most important physicochemical properties driving environmental fate and exposure of
 411 engineered nanoparticles. *Environmental Science: Nano* **2019**, *6* (7), 2049-2060.
- 412 (10) Hedberg, J.; Blomberg, E.; Odnevall Wallinder, I. In the search for nanospecific effects of dissolution
 413 of metallic nanoparticles at freshwater-like conditions: a critical review. *Environmental science &*
 414 *technology* **2019**, *53* (8), 4030-4044.
- 415 (11) Petosa, A. R.; Jaisi, D. P.; Quevedo, I. R.; Elimelech, M.; Tufenkji, N. Aggregation and deposition of
 416 engineered nanomaterials in aquatic environments: role of physicochemical interactions. *Environmental*
 417 *science & technology* **2010**, *44* (17), 6532-6549.

