

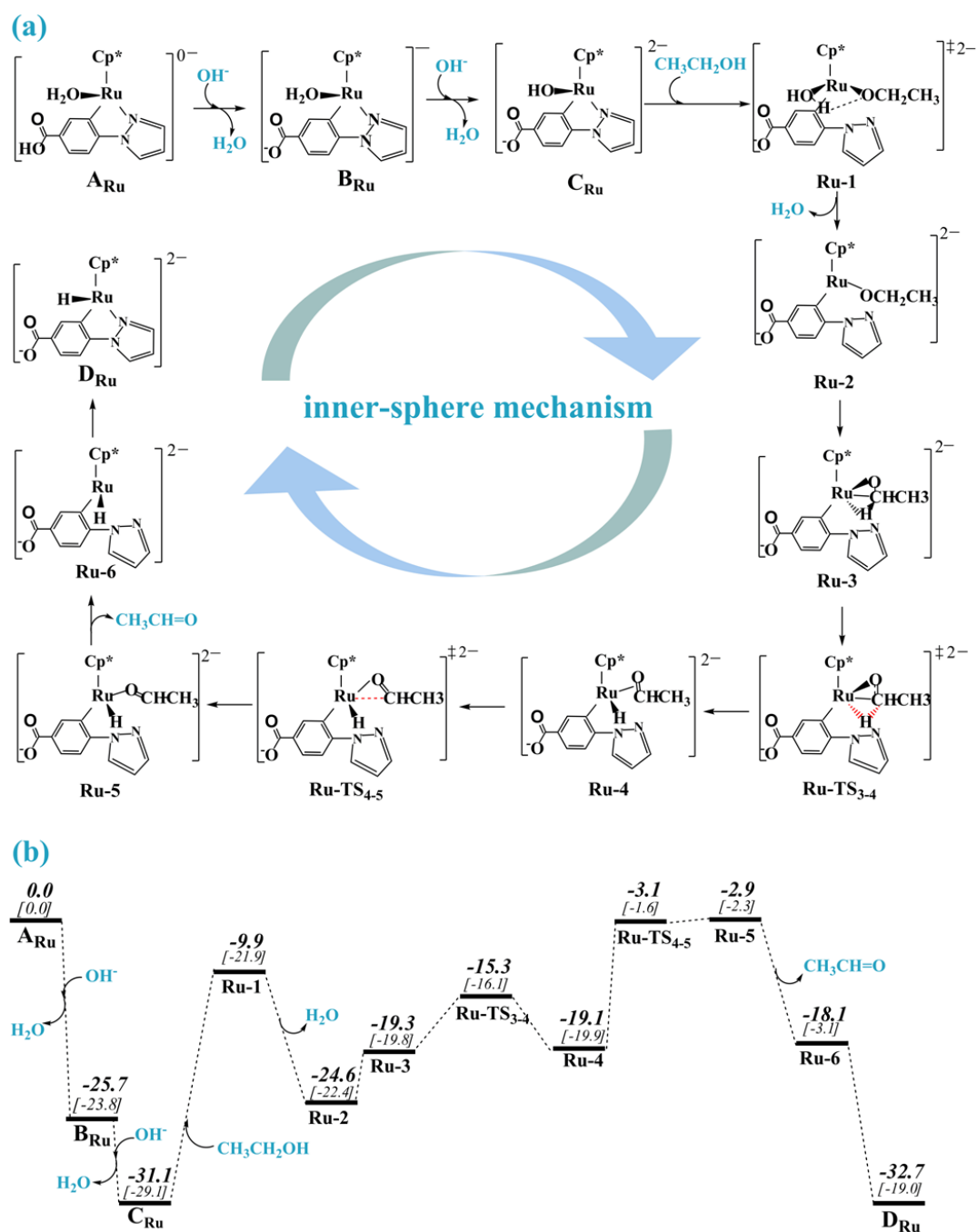
*Supporting Information*

**Computational Mechanistic Study on pH-Dependent Alcohol Dehydrogenation  
Catalyzed by A Novel [C, N] or [C, C] Cyclometalated Cp\*Ir Complex in  
Aqueous Solution**

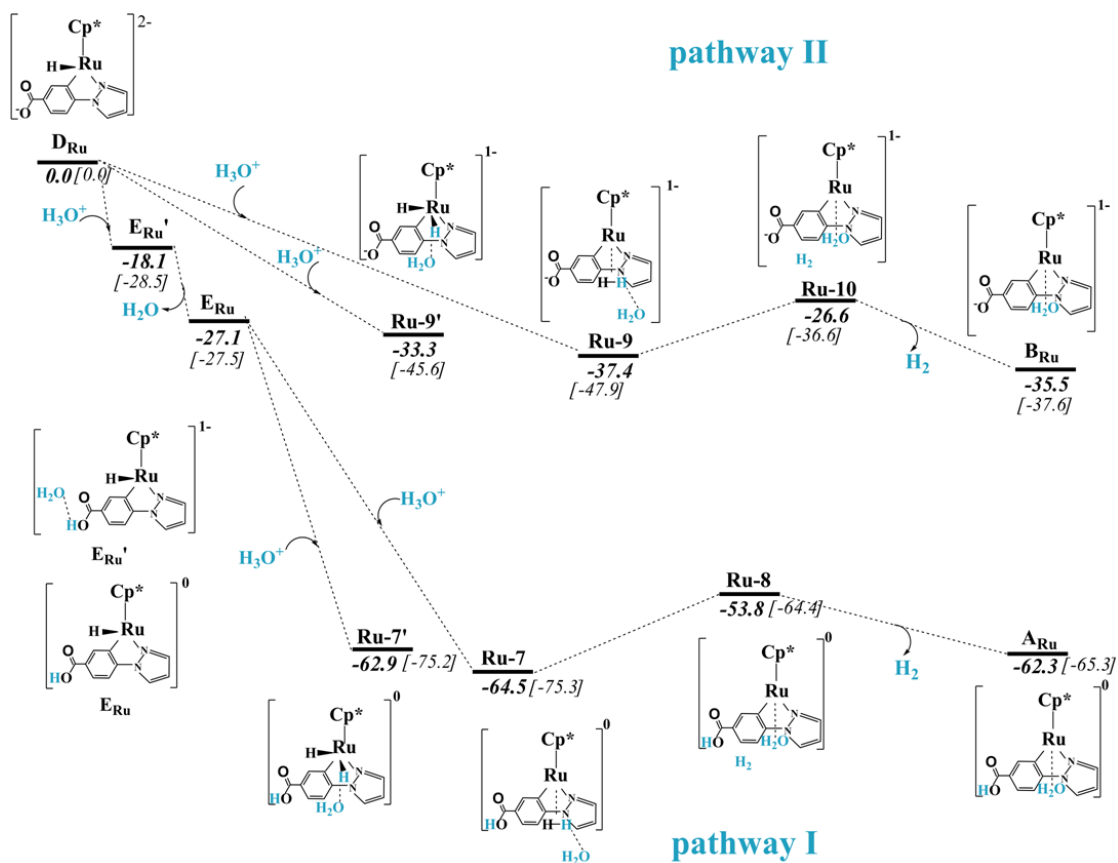
*Dan-Dan Zhang<sup>a</sup>, Xian-Kai Chen<sup>a</sup>, Hui-Ling Liu<sup>a\*</sup>, Xu-Ri Huang<sup>a\*</sup>*

<sup>a</sup>State Key Laboratory of Theoretical and Computational Chemistry, Institute of  
Theoretical Chemistry, Jilin University, Changchun, China, 130023

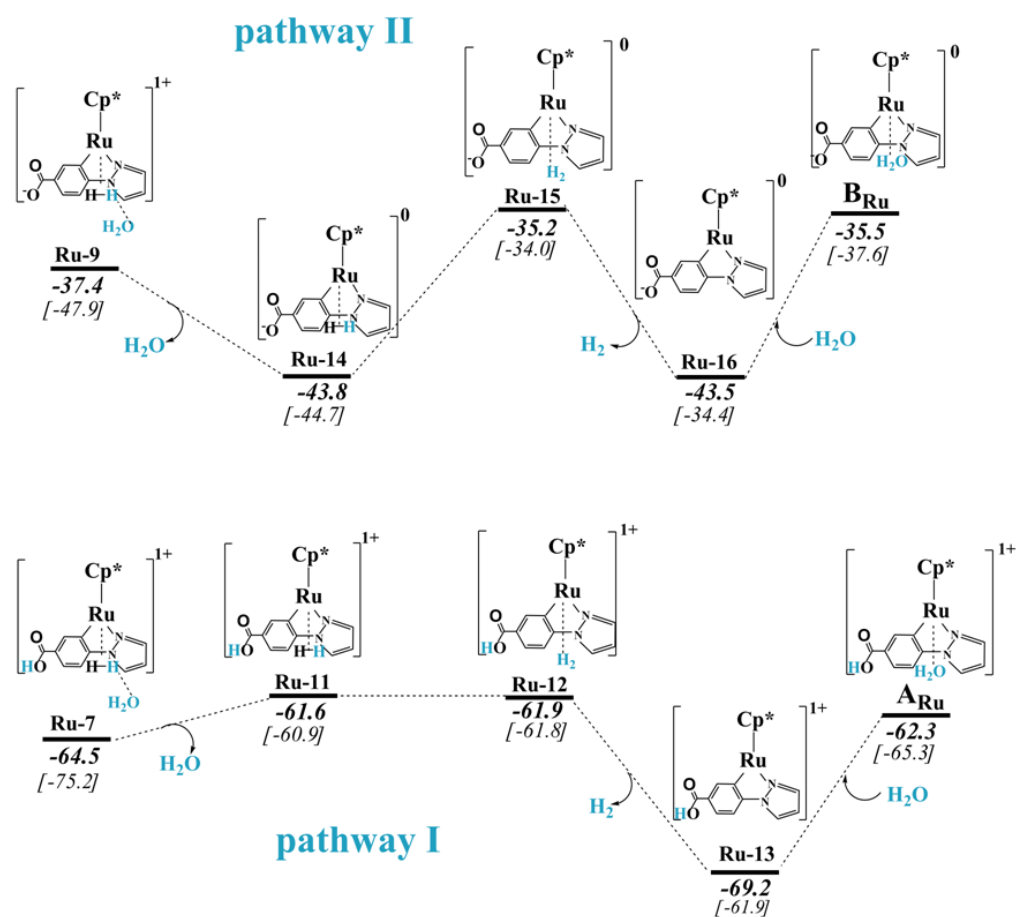
\*E-mail: [huling@jlu.edu.cn](mailto:huling@jlu.edu.cn) (H.-L. L.); [huangxr@jlu.edu.cn](mailto:huangxr@jlu.edu.cn) (X.-R. H.)



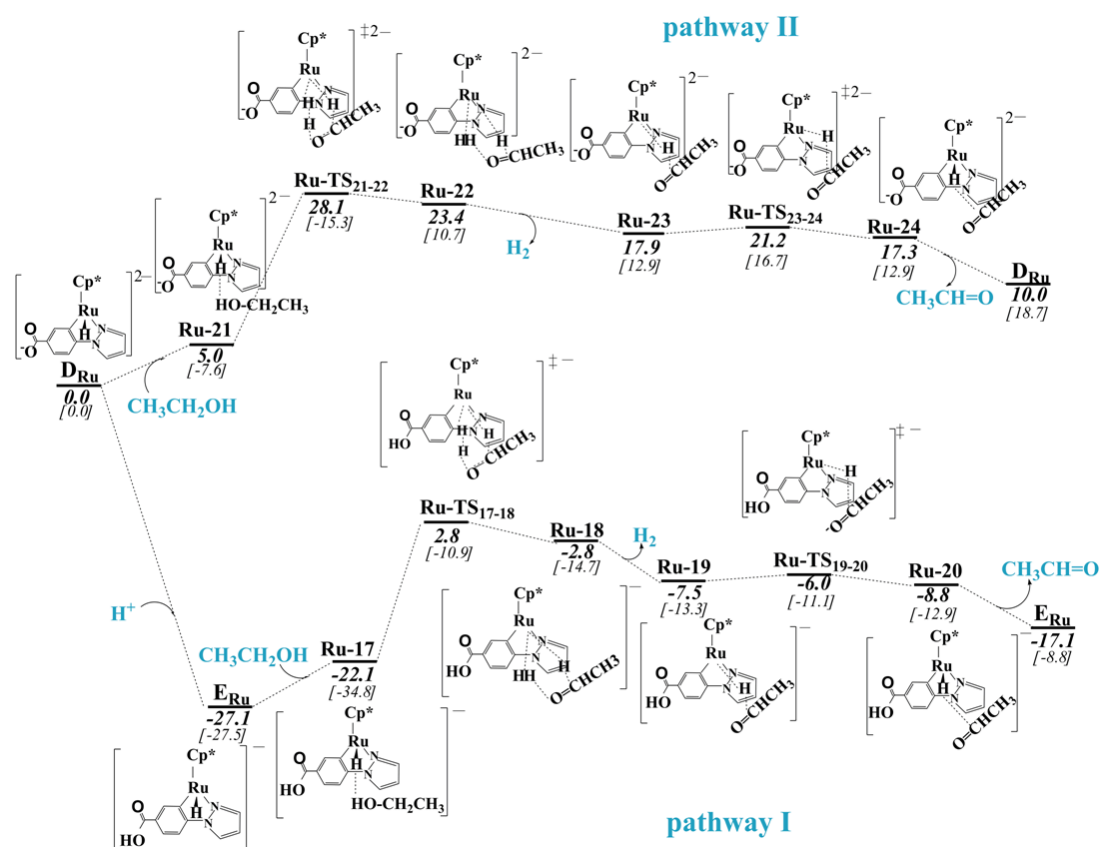
**Figure S1.** Detailed free energies profile of  $D_{Ru}$  formation through inner-sphere mechanism. The values (italic numbers) are given in kcal/mol and enthalpies are listed in square brackets.



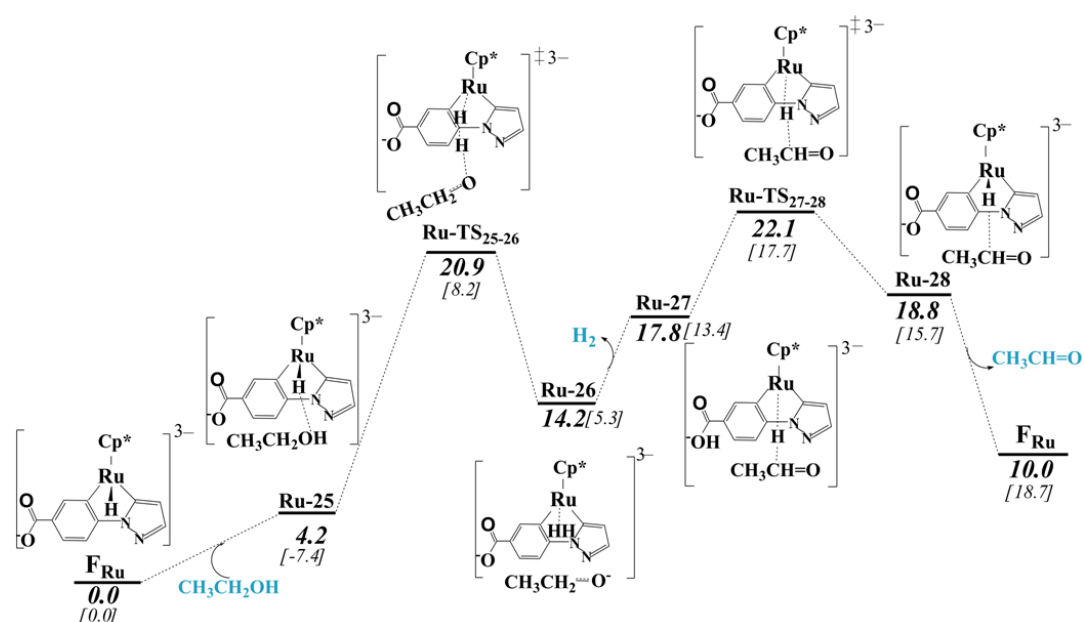
**Figure S2.** Detailed energy profiles of the H<sub>2</sub> formation based on the complex **D<sub>Ru</sub>** and the proton, including the free energies and enthalpies (in brackets) in M06/BSII (SMD, water) level (in kcal/mol).



**Figure S3.** Detailed free energy profiles for another pathways beginning with intermediate **Ru-7** (pathway I) and **Ru-9** (pathway II), where waters are firstly dissociated. The values (italic numbers) are given in kcal/mol and enthalpies are listed in square brackets.

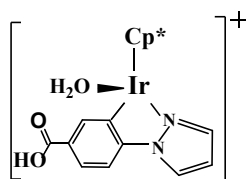


**Figure S4.** Detailed energy profiles of the H<sub>2</sub> formation based on the complex **D<sub>Ru</sub>** and the ethanol, including the free energies and enthalpies (in brackets) in M06/BSII (SMD, water) level (in kcal/mol).



**Figure S5.** Detailed energy profile of the  $\text{H}_2$  formation based on the complex  $\text{F}_{\text{Ru}}$  in the lowest triplet state and the ethanol molecule, including the free energies and enthalpies (in brackets) in M06/BSII (SMD, water) level, (in kcal/mol).

**Cartesian coordinates, atom numbers, imaginary vibrational modes, and Gibbs free energies [in Hartree and at the M06/BSII (SMD, water) level of theory] for all the complexes calculated in this study**



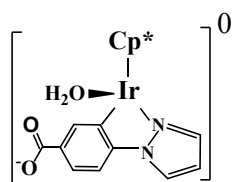
$\text{A}_{\text{Ir}}$

**50**

**E=-1215.589466 (au)**

C	-1.20892400	-1.95823000	2.58976400
C	-1.69108400	-1.23099200	1.41304100
C	-2.76004200	-0.41031700	1.81724000
C	-2.10767800	-1.65968100	3.68982000
C	-2.99901400	-0.63571400	3.24599100
Ir	-0.94047300	0.08554900	3.09950400
C	-1.10559300	-1.34789700	0.04977100
H	-1.54342200	-2.20252400	-0.48096600
H	-1.29375000	-0.45439900	-0.55443700
H	-0.02394500	-1.51670600	0.08991200
C	-0.15011700	-3.00443200	2.58491800
H	0.24542700	-3.17115900	3.59160400
H	-0.54468900	-3.95941600	2.21456800
H	0.69011000	-2.71816000	1.94329800
C	-2.09611400	-2.33658300	5.01333900
H	-2.62972400	-1.76568000	5.77845800
H	-2.59154600	-3.31189200	4.92722100
H	-1.07674600	-2.51150200	5.37128000
C	-4.09909600	-0.00223200	4.02431100
H	-4.23741800	1.04597200	3.73897800
H	-5.04921800	-0.51929600	3.83818600
H	-3.90987800	-0.03421400	5.10154700
C	-3.53388000	0.55290000	0.98902300
H	-3.07511200	0.71129300	0.00890000

H	-4.55284800	0.18037300	0.82411000
H	-3.62000300	1.52638900	1.48509500
C	3.07405800	1.25585000	2.77687100
C	2.89015000	1.26142900	1.40886800
C	1.55032200	0.90591400	1.21853700
N	0.95661300	0.69815900	2.39622000
H	3.95053400	1.46926600	3.37317800
H	3.62714400	1.48738700	0.65242300
H	0.98694800	0.78808900	0.30101800
N	1.89649800	0.91584600	3.34785600
C	0.12664300	0.38084800	4.84215900
C	1.46821300	0.77968800	4.69167100
C	-0.34126100	0.31123200	6.15110900
C	2.31397800	1.05910900	5.75655900
C	0.48290400	0.57487400	7.25088400
H	-1.37670600	0.05174100	6.36799200
C	1.81203000	0.94634300	7.04773400
H	3.34158600	1.37728700	5.59678500
H	2.45964700	1.20518700	7.88348000
C	-0.15441600	0.49146900	8.60279200
O	-1.34595900	0.56855100	8.75460400
O	0.66544700	0.32808500	9.65407400
H	1.56443700	0.11671100	9.37482400
O	-1.35328200	2.36364400	3.30947800
H	-0.67687900	2.91226500	2.88959300
H	-1.32931500	2.57905200	4.25310300



**B<sub>Ir</sub>**

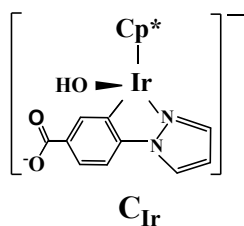
**49**

**E=-1215.133641(au)**

C	-1.19106300	-1.93549000	2.45549500
C	-1.79114100	-1.18218500	1.34944200
C	-2.81649200	-0.38684600	1.88552800
C	-1.98160900	-1.69014300	3.64671200
C	-2.91358400	-0.65294800	3.32511300
Ir	-0.88765300	0.08576200	3.03459000
C	-1.33964100	-1.25152300	-0.06814100
H	-1.81459900	-2.09235600	-0.59014500
H	-1.58471000	-0.33751500	-0.61945800
H	-0.25637700	-1.40383900	-0.13502800

C	-0.11618600	-2.95741900	2.31433600
H	0.39830500	-3.11937000	3.26659600
H	-0.52655300	-3.91973700	1.98098700
H	0.63643600	-2.64217200	1.58312300
C	-1.83858800	-2.39824900	4.94721400
H	-2.17263200	-1.79366100	5.79593900
H	-2.43799500	-3.31758000	4.93007700
H	-0.79816400	-2.67523000	5.14307000
C	-3.93236200	-0.05182300	4.23194200
H	-4.08615300	1.00972100	4.00503600
H	-4.90207100	-0.55544600	4.12415300
H	-3.63339500	-0.12457400	5.28271600
C	-3.66170200	0.61381500	1.17969200
H	-3.32134800	0.78929000	0.15495900
H	-4.70475600	0.27462500	1.13554700
H	-3.65463700	1.57467500	1.70765500
C	3.18509000	1.03387000	2.85378400
C	3.06275000	1.01995100	1.47320600
C	1.71383000	0.75685400	1.23155100
N	1.05621100	0.62165600	2.39078100
H	4.04171900	1.19772200	3.49302200
H	3.84627100	1.17749000	0.74676000
H	1.17814800	0.66163600	0.29508800
N	1.96801700	0.79407700	3.37701600
C	0.11237500	0.38256300	4.79317800
C	1.47108600	0.72187700	4.70814100
C	-0.45867200	0.39026500	6.05929900
C	2.25021900	1.01121800	5.82536000
C	0.28950500	0.66371600	7.20392100
H	-1.51216000	0.17745600	6.24674600
C	1.64514500	0.96603700	7.07765200
H	3.30348900	1.27274400	5.72219400
H	2.19201900	1.17345100	7.99538500
C	-0.41739200	0.60332800	8.58647300
O	-1.62253400	0.28278700	8.51819500
O	0.32208300	0.87804200	9.54594500
O	-1.21079800	2.36996400	3.33040200
H	-0.41879200	2.83111400	3.02102400
H	-1.16856500	2.41862700	4.30122100



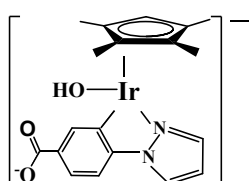


**48**

**E=-1214.659638(au)**

C	-1.22585700	-2.01850800	2.38238600
C	-1.82073500	-1.17904600	1.34560000
C	-2.79255700	-0.35899300	1.95909000
C	-1.89986100	-1.74779400	3.61808700
C	-2.82816900	-0.65971200	3.38189000
Ir	-0.82209900	0.05573300	3.01039700
C	-1.44116300	-1.20247900	-0.09663000
H	-2.00766800	-1.96072800	-0.65679200
H	-1.61542200	-0.23225900	-0.57546300
H	-0.37792500	-1.44209700	-0.22122900
C	-0.19202400	-3.06561300	2.13821100
H	0.31176100	-3.34538900	3.06916900
H	-0.62556800	-3.97653100	1.69994400
H	0.58226000	-2.70248700	1.45049400
C	-1.72086800	-2.47567500	4.90588400
H	-1.80051800	-1.80978500	5.77251100
H	-2.48124600	-3.26128600	5.01296000
H	-0.73436000	-2.94829200	4.96169600
C	-3.79586300	-0.07530800	4.35487900
H	-3.87072900	1.01025700	4.22004500
H	-4.80169400	-0.50385900	4.23507600
H	-3.47991500	-0.25069200	5.38889800
C	-3.55192400	0.76140900	1.33793600
H	-3.49658000	0.73454500	0.24455900
H	-4.60974500	0.72975700	1.62724700
H	-3.12191100	1.71409300	1.68660400
C	3.20067700	1.16828600	2.94950100
C	3.14909600	1.02613500	1.57358000
C	1.84638700	0.59088300	1.30410400
N	1.16214200	0.46392800	2.44152300
H	3.99392300	1.49366100	3.60795900
H	3.94320400	1.21859500	0.86631000
H	1.36021500	0.37651400	0.36042500
N	1.99086700	0.82475100	3.44015800
C	0.07771200	0.48128600	4.79594200
C	1.44012600	0.80954200	4.74932900

C	-0.50721300	0.48445100	6.06128200
C	2.20150400	1.09109100	5.88243400
C	0.22076700	0.73115300	7.22454700
H	-1.56796200	0.28482100	6.21056600
C	1.57892900	1.04134600	7.12283300
H	3.26132800	1.33638300	5.79699200
H	2.11171700	1.23802800	8.05112800
C	-0.47156000	0.62070100	8.60565900
O	-1.65852900	0.22912300	8.56278600
O	0.25082900	0.92205200	9.57819000
O	-1.06945000	2.09954200	2.80091200
H	-0.92847500	2.48794700	3.67226000



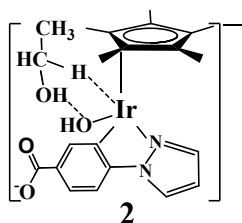
1

48

E=-1214.632623(au)

C	-0.68461000	-1.98040400	-1.16832900
C	-1.09115000	-1.94570400	-2.46112900
C	-2.02298100	-0.82898500	-2.63356700
C	-1.31513100	-0.84840500	-0.42898100
C	-2.20166900	-0.18997300	-1.44001400
Ir	0.01018200	0.75765200	-0.21001900
C	-0.64450900	-2.82395400	-3.58093700
H	-1.48639200	-3.34690400	-4.05751600
H	-0.14355700	-2.25072700	-4.37676600
H	0.06369000	-3.58505400	-3.23478100
C	0.27824100	-2.92950300	-0.53944900
H	0.71887400	-2.50925600	0.37233900
H	-0.20889900	-3.87370000	-0.25576300
H	1.10595700	-3.17967500	-1.21764500
C	-1.93129800	-1.20722200	0.91004100
H	-2.40760700	-0.34203200	1.38131900
H	-2.69493000	-1.99073600	0.77252200
H	-1.17563400	-1.58866900	1.60631400
C	-3.23000600	0.84375800	-1.10571900
H	-2.84263300	1.61084900	-0.42455100
H	-3.61281800	1.33918300	-2.00585700
H	-4.09146600	0.37990900	-0.59931300
C	-2.66938900	-0.52690500	-3.94174700
H	-1.92001400	-0.34789000	-4.72763100

H	-3.28237800	-1.37049100	-4.29126900
H	-3.31430300	0.35629400	-3.89071800
C	3.42588300	-0.91879100	-1.85408100
C	2.83932300	-0.74824000	-3.09488200
C	1.57210100	-0.21021000	-2.83187800
N	1.39672300	-0.06987800	-1.51521900
H	4.39766000	-1.29102000	-1.56151100
H	3.27235200	-0.97799100	-4.05795300
H	0.77065100	0.06554600	-3.50615300
N	2.53426400	-0.50151500	-0.92612600
C	1.41512700	0.16076300	1.06000300
C	2.56452400	-0.41527400	0.48411600
C	1.35934100	0.20908500	2.45417200
C	3.62032400	-0.90910300	1.24509600
C	2.40489800	-0.27334000	3.24122100
H	0.50637000	0.60823000	3.00400300
C	3.53173300	-0.82580400	2.62766800
H	4.48885200	-1.35877000	0.76183000
H	4.31480300	-1.19105200	3.28893700
C	2.30680000	-0.21021900	4.78967000
O	1.24381000	0.27739700	5.22400000
O	3.30717800	-0.65992100	5.38514600
O	-1.03048500	1.98649600	0.93064100
H	-0.87289200	1.84319800	1.87106900



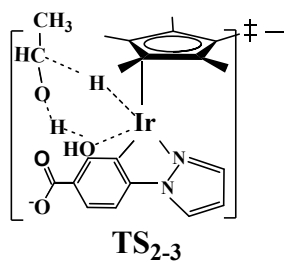
57

**E=-1369.614435(au)**

C	-0.65149000	-2.23130800	-1.24528300
C	-0.98075500	-2.08909200	-2.56546700
C	-2.04043800	-1.10396100	-2.66855400
C	-1.46295900	-1.30407500	-0.43597300
C	-2.38762800	-0.67291000	-1.40428200
Ir	-0.35790100	0.57255600	-0.28774100
C	-0.36286300	-2.76406500	-3.74645100
H	-1.06260800	-3.45236600	-4.24409500
H	-0.03670900	-2.04773700	-4.51635800
H	0.51818600	-3.35044800	-3.46016300
C	0.38629100	-3.12281700	-0.65457900

H	0.94560600	-2.61362200	0.14246300
H	-0.05962600	-4.01878600	-0.19662400
H	1.10946200	-3.46641400	-1.40580100
C	-1.97445100	-1.81537000	0.89428300
H	-2.60450000	-1.07744300	1.40737700
H	-2.58028800	-2.72773700	0.76863400
H	-1.14840700	-2.05210900	1.57563400
C	-3.58662700	0.15520600	-1.04095900
H	-3.35724100	1.18088600	-0.71740700
H	-4.27280700	0.24320200	-1.89166500
H	-4.14982800	-0.31844800	-0.22305100
C	-2.63502500	-0.68192900	-3.96994300
H	-1.88619500	-0.22877500	-4.63751400
H	-3.05198300	-1.53869900	-4.51961200
H	-3.43503600	0.05480000	-3.83838500
C	3.24418000	-0.52669900	-1.82470300
C	2.67579000	-0.34934700	-3.07374800
C	1.35254700	0.03781500	-2.82964500
N	1.13811700	0.07825500	-1.51532100
H	4.24137300	-0.81380100	-1.52209900
H	3.15618100	-0.47585600	-4.03301100
H	0.54617900	0.27775500	-3.50951700
N	2.29571700	-0.25572600	-0.90237800
C	1.02262100	0.10609100	1.06072800
C	2.26126200	-0.27281400	0.51178300
C	0.89692700	0.06717400	2.44665400
C	3.33743900	-0.68233900	1.29536400
C	1.95898500	-0.33836700	3.25602000
H	-0.02337100	0.32295600	2.97451000
C	3.17480700	-0.70603800	2.67316100
H	4.27845700	-0.98140900	0.83158600
H	3.96753500	-1.01284800	3.35209600
C	1.77732900	-0.38861300	4.79819100
O	0.64272000	-0.05810300	5.19872700
O	2.79418000	-0.75497300	5.42078500
O	0.27825400	2.58709600	-0.39324900
H	1.04813500	2.70592800	0.17510800
C	-3.00240600	1.69974500	2.38597500
H	-2.78920100	0.85836900	3.05422700
H	-3.20826100	2.58526600	2.99663300
H	-3.89551700	1.47770000	1.79114100
C	-1.81768500	1.99113200	1.49694800
H	-1.69504800	0.96041200	0.94259100
H	-0.90268400	2.12257800	2.09167300

O	-2.06573800	3.03223600	0.64154900
H	-1.19141000	3.16436900	0.17397800

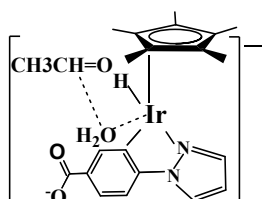


**57 -529.73i cm<sup>-1</sup>**

**E=-1369.604408(au)**

C	-1.01881900	-1.50933700	2.78417900
C	-1.34836800	-1.41980900	1.46504300
C	-2.42041500	-0.44285400	1.32182200
C	-1.84229500	-0.55281600	3.56415200
C	-2.77100200	0.03652700	2.56030800
Ir	-0.78448500	1.29002600	3.71578200
C	-0.72425700	-2.12927800	0.30858300
H	-1.41906100	-2.83448100	-0.17181000
H	-0.39688000	-1.43326800	-0.47927200
H	0.15815100	-2.70169800	0.61680000
C	0.01769400	-2.37475500	3.41240900
H	0.56851000	-1.83634100	4.19556600
H	-0.43108700	-3.25470900	3.89731200
H	0.74673400	-2.74307100	2.67889700
C	-2.39974600	-1.06999500	4.87502100
H	-3.05343800	-0.33373000	5.35794400
H	-2.98763700	-1.98978100	4.72154200
H	-1.59711500	-1.29706800	5.58664900
C	-3.94746900	0.90877000	2.88751000
H	-3.68107300	1.93447200	3.18181200
H	-4.62873500	0.98831100	2.03180000
H	-4.52420200	0.48379900	3.72194800
C	-3.01490000	-0.08805300	0.00084600
H	-2.26738500	0.34555000	-0.68107600
H	-3.41272100	-0.97606500	-0.51164700
H	-3.82850700	0.63923800	0.09483200
C	2.88339500	0.20004700	2.17500600
C	2.33650400	0.33395000	0.91001900
C	1.00895000	0.72120900	1.12515500
N	0.77053300	0.81347100	2.43444800
H	3.87595400	-0.07781000	2.50065500
H	2.83372800	0.17556600	-0.03609500
H	0.20630700	0.91538500	0.42443900

N	1.91845900	0.49873400	3.07096900
C	0.61852200	0.81648400	5.03983400
C	1.86617000	0.47624000	4.48784600
C	0.48543400	0.73626800	6.42307800
C	2.94749300	0.07696800	5.27083900
C	1.54990800	0.33321600	7.23020800
H	-0.44734800	0.95684300	6.94482800
C	2.77866600	0.01415400	6.64605900
H	3.89974500	-0.18668100	4.80841100
H	3.57493000	-0.29115800	7.32142500
C	1.35964200	0.22239800	8.76788200
O	0.21319600	0.50224000	9.17302400
O	2.38290600	-0.13693500	9.38520000
O	-0.10168000	3.42900700	3.69640300
H	-0.00804800	3.69421700	2.77685500
C	-3.35818600	2.53417100	6.30070100
H	-3.18916100	1.62797400	6.89283600
H	-3.58533600	3.35809700	6.98781100
H	-4.21980700	2.39568900	5.63848700
C	-2.12710100	2.91551300	5.51368400
H	-1.97471700	1.70985800	4.90013000
H	-1.20502900	2.87773600	6.12476400
O	-2.23367900	3.89801400	4.67227400
H	-1.07740800	3.83934300	4.10315000



3

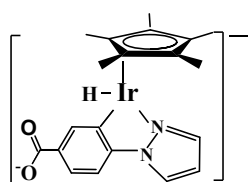
57

**E=-1369.61443(au)**

C	-0.57604500	-2.51183000	-1.74621700
C	-0.80494600	-2.22855200	-3.06432200
C	-1.97839400	-1.37700200	-3.14687700
C	-1.58871200	-1.82809300	-0.91501100
C	-2.51878800	-1.21430900	-1.88422400
Ir	-0.85382400	0.15090900	-0.63001100
C	-0.00193400	-2.64373600	-4.25245000
H	-0.56314400	-3.32521700	-4.91004600
H	0.29578600	-1.79081500	-4.88138600
H	0.91925600	-3.16054600	-3.95865600
C	0.54022700	-3.30422500	-1.16072200
H	1.00900200	-2.76746800	-0.32430700

H	0.18648500	-4.26422100	-0.75510700
H	1.32326100	-3.52546500	-1.89720700
C	-2.07726400	-2.53081400	0.32929000
H	-2.83621700	-1.94082900	0.85294300
H	-2.50802700	-3.51869100	0.09493800
H	-1.25500500	-2.68118300	1.03922700
C	-3.90332400	-0.72971900	-1.58062600
H	-4.00727400	-0.44993000	-0.52865400
H	-4.17660300	0.15260000	-2.17455200
H	-4.65149300	-1.50956700	-1.79527200
C	-2.51772300	-0.84656300	-4.43219800
H	-1.75616600	-0.28427600	-4.99271900
H	-2.85150900	-1.65830000	-5.09638500
H	-3.37068100	-0.17790200	-4.27207600
C	3.28540300	-0.34786100	-1.46217000
C	3.03222000	-0.24354100	-2.81690100
C	1.64792700	-0.03714800	-2.90426600
N	1.09757900	-0.02311100	-1.69373300
H	4.20726600	-0.50289000	-0.91932200
H	3.75063400	-0.30540500	-3.62208500
H	1.01384700	0.09086200	-3.77294100
N	2.10465700	-0.20600400	-0.81659500
C	0.41911500	-0.01447800	0.89381200
C	1.78087000	-0.19063800	0.57002100
C	0.11468800	0.09623600	2.25318800
C	2.77318200	-0.31619800	1.54077800
C	1.09477700	0.02451200	3.24517200
H	-0.90912500	0.28228600	2.57137400
C	2.42040200	-0.21727700	2.87967000
H	3.81527000	-0.46278400	1.25448900
H	3.15514200	-0.29558700	3.67798200
C	0.74327100	0.31952500	4.71366500
O	-0.35998400	0.91229000	4.86878900
O	1.59189700	-0.00802900	5.56016900
O	-0.38444200	2.40203100	-0.38495600
H	-1.19759300	2.79858200	-0.71492500
C	-0.89688800	3.74528400	4.49738700
H	-0.94183400	2.92182700	5.22329000
H	-0.16935100	4.47686600	4.87178100
H	-1.87082900	4.21875400	4.34536100
C	-0.39772000	3.14353700	3.23277500
H	-2.09653900	0.34292600	0.34627500
H	0.59172500	2.65144800	3.29554800
O	-1.00088300	3.19489400	2.17102200

H	-0.44443700	2.55245700	0.59070000
---	-------------	------------	------------



4

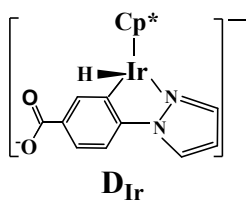
47

**E=-1139.387732(au)**

C	-0.63986900	-2.47869500	-1.66071000
C	-0.82436800	-2.28051400	-2.99359100
C	-2.00067500	-1.42915400	-3.17744300
C	-1.69085100	-1.73733300	-0.90960100
C	-2.57246300	-1.16030000	-1.95918800
Ir	-0.82442400	0.13179200	-0.58362100
C	0.02428200	-2.76202300	-4.12160200
H	-0.51843400	-3.45887400	-4.77749600
H	0.36998500	-1.93832600	-4.76483100
H	0.91752200	-3.28262600	-3.75789800
C	0.45152600	-3.22986700	-0.98150900
H	0.83627700	-2.66505700	-0.12226100
H	0.09964100	-4.19756600	-0.59421500
H	1.29379600	-3.42898600	-1.65636900
C	-2.29178500	-2.42128200	0.29480800
H	-3.07714700	-1.81357100	0.75406700
H	-2.72486200	-3.39429000	0.00906800
H	-1.53393200	-2.60148600	1.06570500
C	-3.92820900	-0.57999700	-1.70989600
H	-3.94926900	0.02481900	-0.79838300
H	-4.25745100	0.05911100	-2.53813300
H	-4.68085500	-1.37582600	-1.59295400
C	-2.47716800	-1.00092600	-4.52226800
H	-1.69150400	-0.46211300	-5.07172600
H	-2.75034100	-1.86540300	-5.14486700
H	-3.34978400	-0.34283400	-4.46112000
C	3.30983000	-0.19024300	-1.51953700
C	3.02217300	-0.14737600	-2.87234200
C	1.63253200	0.01359500	-2.93305800
N	1.11033500	0.05951700	-1.70807500
H	4.24773400	-0.30323900	-0.99407800
H	3.72321000	-0.21873300	-3.69171100
H	0.97576800	0.08845400	-3.79141400
N	2.14340000	-0.05678100	-0.85097400
C	0.48227300	0.01966700	0.90398900



C	1.84789800	-0.04198300	0.54383000
C	0.19572800	-0.00129200	2.27559700
C	2.86958100	-0.09646900	1.48811900
C	1.20025400	-0.07116100	3.24160700
H	-0.83026200	0.02524000	2.63958700
C	2.53496700	-0.11277700	2.83509900
H	3.91459800	-0.12236900	1.17632500
H	3.28315100	-0.16220900	3.62383900
C	0.84996200	-0.11349000	4.75305900
O	-0.37006600	-0.08745100	5.00967600
O	1.84392300	-0.17245000	5.50785900
H	-2.03718200	0.31482200	0.42338500

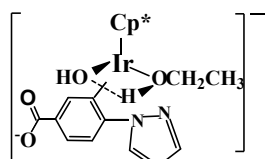


47

**E=-1139.427421(au)**

C	-1.26931900	-2.04866600	2.34656700
C	-1.82329800	-1.13226200	1.36206300
C	-2.78140800	-0.31612100	2.01925200
C	-1.89012400	-1.79551700	3.59400100
C	-2.79343300	-0.67177900	3.42370100
Ir	-0.81195900	0.14736300	2.99094600
C	-1.51031400	-1.15215700	-0.09674300
H	-2.12781000	-1.88363300	-0.64018300
H	-1.67744800	-0.17111100	-0.55721400
H	-0.46273600	-1.42527400	-0.27571500
C	-0.23067900	-3.07577600	2.04399700
H	0.18797500	-3.50046100	2.96230100
H	-0.63769800	-3.90432400	1.44602800
H	0.60435300	-2.64329500	1.47606900
C	-1.66457100	-2.50505400	4.88460200
H	-1.54636300	-1.79940500	5.71733800
H	-2.51194700	-3.16139500	5.12588500
H	-0.75878000	-3.12020000	4.85236000
C	-3.77011900	-0.17865300	4.43952500
H	-3.92351400	0.90273200	4.35147700
H	-4.74854700	-0.67002800	4.32964200
H	-3.41802200	-0.36703400	5.45962800
C	-3.67160300	0.70224000	1.39088400
H	-3.22408600	1.12611200	0.48484500
H	-4.64256700	0.26477700	1.11582300

H	-3.86328900	1.53065300	2.08102800
C	3.24398900	1.11911000	3.00361000
C	3.21810500	0.94202400	1.63065800
C	1.89814100	0.58453500	1.33555900
N	1.17223100	0.54227100	2.45766900
H	4.04116500	1.40529100	3.67521900
H	4.04151300	1.06162700	0.94091800
H	1.42391400	0.37080100	0.38587700
N	2.00129700	0.86917000	3.47100900
C	0.05099100	0.60783400	4.78671200
C	1.42677500	0.88223900	4.76909000
C	-0.54638400	0.59971100	6.04833600
C	2.18298600	1.12267700	5.91631700
C	0.17424100	0.80224200	7.22368300
H	-1.61364900	0.42631000	6.18048900
C	1.54308500	1.07655900	7.14658000
H	3.25281800	1.32780400	5.84803800
H	2.06742700	1.24160100	8.08570000
H	-0.97055200	1.73988100	2.95287800
C	-0.53579900	0.68959100	8.59563200
O	-1.73381700	0.33544400	8.53657400
O	0.18467300	0.95290800	9.58126700



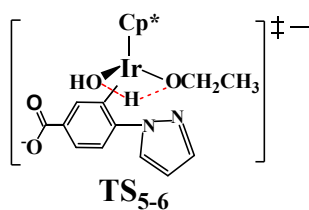
5

57

**E=-1369.6383(au)**

C	-1.05560200	-1.61031400	2.03149500
C	-2.19704500	-0.94037100	1.40478300
C	-3.12581100	-0.61417000	2.40931800
C	-1.32606400	-1.74122900	3.42801800
C	-2.57186700	-1.04349200	3.69795300
Ir	-1.18657700	0.37744100	2.97789000
C	-2.25962400	-0.60924400	-0.04619400
H	-2.33497900	-1.51682100	-0.66170800
H	-3.11692400	0.03135900	-0.27696600
H	-1.35539900	-0.06981700	-0.35761000
C	0.06280300	-2.23409500	1.26942900
H	0.89234800	-2.48500200	1.93450200
H	-0.28014900	-3.14839400	0.76223300
H	0.45388700	-1.55469400	0.50117800
C	-0.50356500	-2.46394600	4.43805700

H	-0.61277900	-2.00839600	5.42847500
H	-0.82077100	-3.51360900	4.50968700
H	0.55911200	-2.42692200	4.17611700
C	-3.29937900	-0.97528000	4.99751000
H	-3.94835300	-0.09284200	5.03224300
H	-3.92737700	-1.86619600	5.14091700
H	-2.62282000	-0.88626900	5.85434400
C	-4.37947000	0.17819600	2.28025200
H	-4.61663200	0.38990000	1.23240900
H	-5.23052300	-0.35322700	2.72470000
H	-4.26139900	1.13940100	2.80017600
C	3.46694300	0.97402800	3.55060700
C	4.19193900	0.20652800	2.66281400
C	3.38219000	-0.92341000	2.45796700
N	2.25559600	-0.86398100	3.16557300
H	3.66277600	1.93473200	4.01056200
H	5.15239000	0.43693800	2.22233900
H	3.56490200	-1.78259800	1.82014100
N	2.31445700	0.31048900	3.81980500
C	-0.00542700	0.80359200	4.63168300
C	1.37644300	0.67067300	4.85209700
C	-0.75193400	1.11986700	5.78136100
C	1.94818400	0.86290000	6.11884300
C	-0.21915200	1.27907800	7.05689700
H	-1.83804700	1.20733000	5.73763700
C	1.16062600	1.17282200	7.21496300
H	3.02538500	0.72517800	6.22548900
H	1.57040600	1.30844400	8.21399000
C	-1.15811200	1.49658300	8.26748800
O	-2.37514400	1.35081800	8.01384500
O	-0.57750400	1.76774700	9.33799700
O	-2.01654000	2.27290000	3.26964900
H	-1.75144900	2.58095000	4.14608100
C	1.78762900	1.56269800	0.53553300
H	1.82038700	0.56146100	0.98197600
H	1.30535400	1.49609300	-0.44805400
H	2.81866800	1.90834700	0.40256600
C	1.00737500	2.48946100	1.43206900
H	1.47061900	2.55231600	2.42988000
H	0.97967600	3.50723700	1.00978400
O	-0.31475100	1.99489400	1.52406600
H	-0.90550000	2.55376900	2.11701800

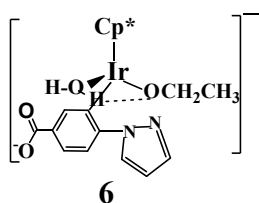


**57 -68.39i cm<sup>-1</sup>**

**E=-1369.631937(au)**

C	-1.04295700	-1.58861600	2.03823900
C	-2.18515100	-0.94152600	1.39204700
C	-3.12103300	-0.61165000	2.38914400
C	-1.34091900	-1.72229900	3.43951500
C	-2.59109500	-1.04591700	3.68532600
Ir	-1.17141900	0.37764700	2.95325900
C	-2.23163400	-0.61256100	-0.05933800
H	-2.28663500	-1.52098700	-0.67532600
H	-3.09322700	0.01713300	-0.30331600
H	-1.32990700	-0.06027500	-0.35373200
C	0.07752800	-2.22928300	1.29439500
H	0.91190000	-2.44965100	1.96379300
H	-0.26345500	-3.16245900	0.82146800
H	0.45729500	-1.57197200	0.50241900
C	-0.51657200	-2.43450100	4.45517800
H	-0.65102200	-1.99480400	5.44938100
H	-0.80720800	-3.49286200	4.50701400
H	0.54788000	-2.36704600	4.20644700
C	-3.32978000	-0.95739700	4.97761500
H	-3.96507100	-0.06443500	5.00263400
H	-3.97490300	-1.83548100	5.12289900
H	-2.65934100	-0.87413700	5.83983800
C	-4.38599600	0.15826600	2.23917900
H	-4.53362800	0.49637800	1.20861500
H	-5.25385500	-0.44831500	2.52999700
H	-4.36447700	1.04849400	2.88001100
C	3.49850400	0.95609400	3.51156700
C	4.22494900	0.17934700	2.63351200
C	3.42207100	-0.95895200	2.44921100
N	2.29833700	-0.89628000	3.16058200
H	3.68698700	1.92730600	3.95190500
H	5.18091400	0.41015300	2.18380400
H	3.60837600	-1.82677300	1.82437000
N	2.35174700	0.28917700	3.79483900
C	0.03242800	0.79179900	4.59677300
C	1.41284700	0.65726200	4.82154200

C	-0.71812700	1.11644400	5.74207900
C	1.97938200	0.85456100	6.08967900
C	-0.18926400	1.28341600	7.01834200
H	-1.80463600	1.20534400	5.69817000
C	1.18934200	1.17291000	7.18187200
H	3.05582400	0.71432100	6.19998200
H	1.59656100	1.31167700	8.18147500
C	-1.13511900	1.51386900	8.22153800
O	-2.35195900	1.38321600	7.95799400
O	-0.55948100	1.77944800	9.29566900
O	-1.96740200	2.38295300	3.27337600
H	-1.62544000	2.68617000	4.12644600
C	1.71358000	1.56723200	0.61903100
H	1.76347800	0.55791500	1.04631700
H	1.24168500	1.50820200	-0.37053300
H	2.74004300	1.93450400	0.49828400
C	0.90193700	2.46262700	1.52667400
H	1.38394000	2.53150000	2.51908400
H	0.87341800	3.48681500	1.11252100
O	-0.41177900	1.98474500	1.62388400
H	-1.15225800	2.52939700	2.41185000

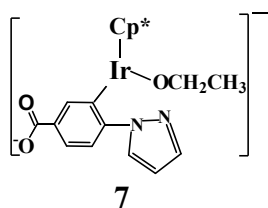


**57**

**E=-1369.635294(au)**

C	-1.01629400	-1.51432700	2.01197100
C	-2.15783600	-0.87699600	1.35444300
C	-3.10980700	-0.57782300	2.34393300
C	-1.35614200	-1.70265700	3.41000000
C	-2.61313300	-1.05619500	3.63872400
Ir	-1.15345000	0.39615600	2.96289400
C	-2.17496600	-0.48960800	-0.08333800
H	-2.00231700	-1.35728000	-0.73355100
H	-3.13112900	-0.03832300	-0.36769000
H	-1.38803800	0.25148600	-0.28149400
C	0.11728900	-2.14913500	1.28496200
H	0.98568300	-2.25475600	1.94011100
H	-0.17725800	-3.14199500	0.91294500
H	0.42178000	-1.54341200	0.42330400
C	-0.53202000	-2.43341200	4.41222500

H	-0.70684900	-2.04876100	5.42248600
H	-0.77759500	-3.50435900	4.40326200
H	0.53459300	-2.30944400	4.19372600
C	-3.38113400	-0.98863000	4.91466100
H	-3.96638600	-0.06312500	4.97041200
H	-4.07912800	-1.83337400	5.00198200
H	-2.72730500	-0.99024300	5.79294700
C	-4.38352800	0.17711700	2.18759000
H	-4.51682600	0.53900200	1.16326600
H	-5.24590900	-0.45180300	2.44629300
H	-4.39673900	1.04972300	2.85211000
C	3.50524700	1.00460600	3.48622300
C	4.26668000	0.22224600	2.64390300
C	3.53096800	-0.96995700	2.53696500
N	2.41268100	-0.93192000	3.25820800
H	3.64249000	2.00746000	3.87091100
H	5.20337300	0.48151100	2.16991500
H	3.76283000	-1.85993500	1.96077400
N	2.40206500	0.29141300	3.82074300
C	0.06955600	0.76460100	4.60920000
C	1.45258500	0.66077900	4.83711600
C	-0.68347600	1.07606000	5.75988500
C	2.01659200	0.89164300	6.10090400
C	-0.15428300	1.29496300	7.02815000
H	-1.77399500	1.12105100	5.73405900
C	1.22649100	1.22035700	7.18960600
H	3.09620300	0.77538100	6.20800800
H	1.63475900	1.39351600	8.18326300
C	-1.10378600	1.56229500	8.22205300
O	-2.32188000	1.46141300	7.95195200
O	-0.52816500	1.83199500	9.29491100
O	-2.06526600	2.44788900	3.51653400
H	-1.65988900	2.64816200	4.37549300
C	1.58243000	1.30469500	0.57172400
H	1.62267500	0.32085100	1.05582900
H	1.03484600	1.20613900	-0.37629700
H	2.61275400	1.61355700	0.35085200
C	0.87678300	2.29660400	1.47697600
H	1.45280100	2.40059200	2.41751600
H	0.89633800	3.29371300	0.99407100
O	-0.44799000	1.94974500	1.70513100
H	-1.42866200	2.75023100	2.80908900

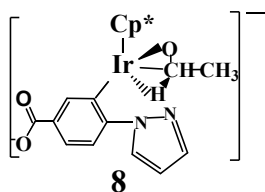


54

E=-1293.206167(au)

C	-1.24639600	-1.96405600	2.54868300
C	-2.11850500	-1.37148700	1.52570100
C	-3.13603800	-0.66429200	2.18922600
C	-1.80732900	-1.70334000	3.84028700
C	-2.90939500	-0.80362500	3.63503900
Ir	-1.15111600	0.16398500	2.86612500
C	-1.85132100	-1.42812400	0.06190800
H	-2.09023800	-2.41496400	-0.35810700
H	-2.43484600	-0.67534000	-0.47801900
H	-0.79260600	-1.22257800	-0.14033600
C	-0.07514000	-2.84009700	2.27450000
H	0.69530900	-2.70768800	3.04022300
H	-0.37789900	-3.89707800	2.25468500
H	0.38918100	-2.59379700	1.31427400
C	-1.31768700	-2.23914200	5.14348900
H	-1.54713900	-1.58071700	5.99215500
H	-1.76887200	-3.22182200	5.33862200
H	-0.22889400	-2.36480800	5.12807700
C	-3.81261600	-0.26131800	4.68892900
H	-4.08400200	0.77928300	4.47563900
H	-4.74195300	-0.84768000	4.72660700
H	-3.35488100	-0.28636000	5.68521900
C	-4.19954300	0.18758400	1.59117100
H	-3.98086800	0.42319300	0.54441400
H	-5.18280500	-0.30064500	1.63828200
H	-4.27284400	1.14031600	2.12892500
C	3.28998600	1.42946000	2.85143300
C	3.71485300	1.03830100	1.59786300
C	2.83613400	-0.00223700	1.25269200
N	1.94797000	-0.24317600	2.21541600
H	3.62568300	2.21070400	3.52131900
H	4.52623300	1.45658300	1.01807100
H	2.81046100	-0.59631500	0.34523100
N	2.23861400	0.64197600	3.18639800
C	0.09889400	0.67738200	4.41076800
C	1.50167000	0.69241800	4.41586500

C	-0.50521800	0.74870600	5.67040500
C	2.23706200	0.75569300	5.60605000
C	0.18978600	0.73409700	6.87247800
H	-1.58752200	0.73644700	5.76463700
C	1.58301000	0.77113200	6.83184300
H	3.32664400	0.73386400	5.55199000
H	2.12207000	0.76790800	7.77744200
C	-0.59663200	0.52209100	8.18213600
O	-1.78314100	0.13874300	8.01239200
O	0.04356700	0.71088300	9.23329400
C	0.75289300	3.30918800	0.96883100
H	1.42739300	2.48019000	0.71976500
H	0.13227200	3.52143500	0.08930700
H	1.36272200	4.19600300	1.18805500
C	-0.11644900	2.93658400	2.15482400
H	0.51699500	2.75862500	3.03806200
H	-0.77403700	3.78921700	2.41054700
O	-0.90769300	1.82961400	1.83313700



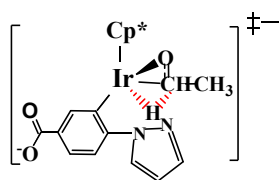
54

**E=-1293.187847(au)**

C	-0.55034600	-2.00214900	-1.19115900
C	-1.49781800	-1.36001500	-2.09831500
C	-2.49676400	-0.74025800	-1.32449400
C	-1.02572900	-1.83488400	0.14570700
C	-2.19472300	-0.97708500	0.08741500
Ir	-0.50322700	0.12858200	-0.63767300
C	-1.34531100	-1.34571900	-3.58120900
H	-1.54574000	-2.33650800	-4.01245200
H	-2.02873500	-0.63147700	-4.05288800
H	-0.32240900	-1.06719000	-3.86815700
C	0.60240000	-2.84768500	-1.61005800
H	1.42344900	-2.77163100	-0.89071500
H	0.30125000	-3.90095900	-1.70799900
H	1.00208600	-2.51799800	-2.57681900
C	-0.44128700	-2.45250200	1.37001400
H	-0.72704400	-1.91305800	2.28080000
H	-0.78300400	-3.49276400	1.46167500
H	0.65422500	-2.45414400	1.32019900
C	-3.09650100	-0.60931600	1.21807600



H	-3.47083000	0.41471800	1.09723700
H	-3.96821200	-1.28012700	1.23825800
H	-2.60709400	-0.66005000	2.20056200
C	-3.62238900	0.11415700	-1.79427300
H	-3.56465700	0.30373100	-2.87154700
H	-4.59319400	-0.35347400	-1.58119600
H	-3.60026300	1.08702800	-1.28761700
C	3.62425700	1.38212000	-0.57189200
C	4.19166200	0.91209700	-1.73949200
C	3.70538300	-0.40402100	-1.84424100
N	2.90763300	-0.72171500	-0.82674300
H	3.68130300	2.33673000	-0.06359800
H	4.86083600	1.43891700	-2.40596900
H	3.91060000	-1.14425500	-2.61057900
N	2.86358800	0.38395400	-0.06227900
C	0.64979500	0.53798100	1.02161300
C	2.04602300	0.45855300	1.11935600
C	-0.03890700	0.61291600	2.23277900
C	2.70201900	0.43837700	2.35500100
C	0.57188400	0.47354100	3.47461600
H	-1.12269500	0.68087700	2.24528100
C	1.96475300	0.42770800	3.53173600
H	3.79148000	0.38025800	2.36528400
H	2.43165400	0.34818800	4.51194400
C	-0.30684100	0.20105800	4.71172100
O	-1.46936500	-0.19159500	4.43342500
O	0.24890600	0.34879300	5.81571700
C	0.15326300	2.31095200	-3.14067800
H	-0.66541100	1.67273000	-3.49678000
H	-0.12602400	3.35506900	-3.32412300
H	1.06294300	2.08323100	-3.71273600
C	0.35958500	2.09353100	-1.65263300
H	0.87393600	1.00791200	-1.58498900
H	1.21219700	2.69176400	-1.26718800
O	-0.75910600	2.19093000	-0.89413400



TS<sub>8-9</sub>

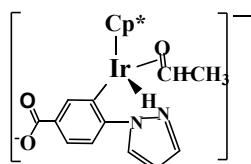
54 -483.76i cm<sup>-1</sup>

E=-1293.180757(au)

C	-1.06739600	-1.68081200	2.40844400
---	-------------	-------------	------------

C	-2.02396600	-1.06852300	1.49908100
C	-3.03676600	-0.46791600	2.28035000
C	-1.56825400	-1.52853700	3.74848400
C	-2.75926800	-0.72845000	3.68789300
Ir	-1.03678500	0.44810500	2.92973900
C	-1.89356700	-1.07971400	0.01353600
H	-2.08915600	-2.08077200	-0.39612200
H	-2.59572100	-0.38565400	-0.46139200
H	-0.88078100	-0.79209700	-0.29764500
C	0.09139500	-2.52653100	2.00705500
H	0.90132300	-2.44805700	2.73869100
H	-0.20677100	-3.58115500	1.91039300
H	0.50329500	-2.19890900	1.04482400
C	-0.96396700	-2.13168400	4.97098100
H	-1.35866700	-1.68163300	5.88911800
H	-1.17563100	-3.20985000	4.99143800
H	0.12476300	-1.99749700	4.98035600
C	-3.65969600	-0.36401500	4.82203100
H	-4.07838800	0.64004900	4.67827200
H	-4.50431900	-1.06631600	4.88155000
H	-3.15147500	-0.36015300	5.79816900
C	-4.18763800	0.35146800	1.80509900
H	-4.15009300	0.51615100	0.72269600
H	-5.14327100	-0.13616900	2.04032100
H	-4.18804500	1.33523100	2.29078500
C	2.93376400	1.58156800	2.88697100
C	3.57069700	1.03612100	1.79030300
C	3.31363000	-0.34284700	1.90415300
N	2.58027500	-0.62550900	2.97786700
H	2.84735000	2.59800000	3.25072600
H	4.14733500	1.55474400	1.03647100
H	3.64082000	-1.14808400	1.25482200
N	2.35133100	0.56331300	3.56355400
C	0.12473300	0.83988900	4.59094600
C	1.51131400	0.68263500	4.72590400
C	-0.59700100	0.94897400	5.78090500
C	2.12639900	0.60295600	5.97929200
C	-0.03224800	0.75215300	7.03706100
H	-1.67613300	1.07520200	5.75519200
C	1.35329100	0.61810000	7.13280300
H	3.20967600	0.48375000	6.02102600
H	1.78492600	0.49578100	8.12464500
C	-0.95628600	0.50002300	8.24463500
O	-2.11979300	0.13937100	7.92748200

O	-0.43290100	0.62621500	9.36645000
C	-0.58956800	2.52338800	0.49863000
H	-1.49749300	1.98469400	0.20403000
H	-0.71938700	3.58320800	0.24496600
H	0.26556100	2.13032700	-0.06635600
C	-0.37128900	2.39241100	1.99052900
H	0.27990800	1.11160900	2.08421600
H	0.56946800	2.87047200	2.33072500
O	-1.40540700	2.55035200	2.78911900



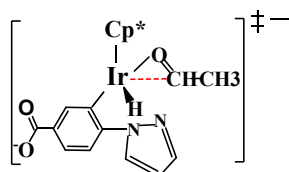
9

54

E=-1293.189769(au)

C	-0.48884100	-1.90991900	-1.02784500
C	-1.32867400	-1.31559900	-2.06289500
C	-2.40551300	-0.67353300	-1.40360700
C	-1.16751400	-1.75558500	0.24163600
C	-2.30045300	-0.94039300	0.02868200
Ir	-0.39580100	0.24883500	-0.70520300
C	-1.09037200	-1.41729800	-3.53166600
H	-1.44777600	-2.37780200	-3.93026900
H	-1.60323600	-0.61865200	-4.07960400
H	-0.02234900	-1.33854200	-3.76435900
C	0.68843500	-2.79833100	-1.25787700
H	1.45049100	-2.65695800	-0.48357000
H	0.38737500	-3.85597000	-1.26685600
H	1.17337700	-2.57145300	-2.21417600
C	-0.70512500	-2.32945500	1.53605300
H	-1.07125400	-1.76528700	2.40555100
H	-1.05504900	-3.36841600	1.62063500
H	0.38978600	-2.34567300	1.58778500
C	-3.24961200	-0.44658300	1.06976500
H	-3.55667200	0.58568300	0.85905900
H	-4.16125700	-1.06115500	1.09018600
H	-2.80476700	-0.45609000	2.07621200
C	-3.53578300	0.07955400	-2.01837900
H	-3.39889700	0.20833400	-3.09791600
H	-4.48634600	-0.44911100	-1.86315400
H	-3.64084300	1.07534000	-1.56889200
C	3.44397200	1.17531300	-0.85258400

C	4.19619500	0.59320300	-1.85226600
C	4.18645600	-0.77574700	-1.52792100
N	3.48843300	-1.02223100	-0.42150400
H	3.16517100	2.20201500	-0.65218900
H	4.68673900	1.08707900	-2.68000700
H	4.66869900	-1.59641200	-2.04805200
N	3.04152600	0.18416200	-0.02333400
C	0.80469100	0.55923000	0.94001400
C	2.17420600	0.32016900	1.11017000
C	0.04255800	0.66691700	2.10577600
C	2.73174400	0.15477200	2.38234000
C	0.54779900	0.39606900	3.37239900
H	-1.02988200	0.83991000	2.04224900
C	1.91917500	0.17575900	3.50823100
H	3.80316700	-0.03229800	2.45618400
H	2.30924600	-0.00753600	4.50764400
C	-0.43274800	0.15040200	4.53518800
O	-1.59812700	-0.15577200	4.16402100
O	0.04778400	0.22363900	5.67936900
C	-0.82673500	2.49724400	-2.81638300
H	-1.81639800	2.04395600	-2.94217800
H	-0.92504200	3.57865400	-2.99336600
H	-0.14461000	2.09015500	-3.57280500
C	-0.29249700	2.24260600	-1.43070200
H	1.00650200	0.25855700	-1.45610300
H	0.72145500	2.64429900	-1.25622900
O	-1.09563100	2.22604600	-0.40067400



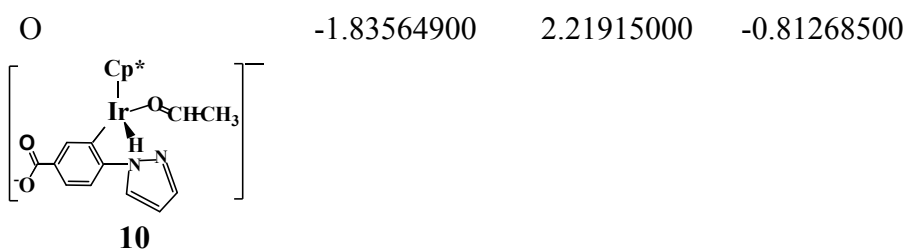
TS<sub>9-10</sub>

54 -63.92i cm<sup>-1</sup>

E=-1293.177091(au)

C	-0.37948800	-1.98909500	-1.07034000
C	-1.32428500	-1.60327700	-2.12356800
C	-2.46956700	-1.08458700	-1.47733200
C	-1.08278900	-1.88122700	0.21254600
C	-2.32064600	-1.26623800	-0.02712100
Ir	-0.62595700	0.09169600	-0.87767300
C	-1.08439800	-1.74549700	-3.58766800
H	-1.30776300	-2.76580100	-3.93251900
H	-1.70588800	-1.05158800	-4.16457500

H	-0.03897900	-1.53002000	-3.83417400
C	0.92328000	-2.68127300	-1.28265100
H	1.62654400	-2.46622700	-0.46942500
H	0.79091100	-3.77180500	-1.34836200
H	1.40009800	-2.33557300	-2.20740400
C	-0.52681900	-2.27965100	1.53498800
H	-0.98088000	-1.71464100	2.35972900
H	-0.70194300	-3.35155600	1.70475600
H	0.55515100	-2.10840700	1.57665500
C	-3.30625200	-0.82040200	1.00078200
H	-3.77442500	0.12526300	0.69869000
H	-4.11185100	-1.55766000	1.12831800
H	-2.83425300	-0.64863600	1.97996800
C	-3.67737800	-0.49093400	-2.11677100
H	-3.48842200	-0.22929900	-3.16355200
H	-4.52868300	-1.18590900	-2.08515400
H	-3.98168400	0.42493700	-1.59730500
C	3.02602400	0.78646600	-1.38028800
C	3.98589300	0.13427700	-2.12739700
C	4.36570600	-0.95032600	-1.31720500
N	3.69787300	-0.97171100	-0.16668300
H	2.43512200	1.67190000	-1.57097900
H	4.35775700	0.41093700	-3.10473000
H	5.10088200	-1.72172300	-1.52004400
N	2.87754600	0.09919800	-0.22427000
C	0.63563800	0.62347800	0.67947400
C	2.00714800	0.40325600	0.87414000
C	-0.11205100	0.83848600	1.85021800
C	2.57749700	0.38362500	2.15368200
C	0.40311300	0.71723500	3.13543800
H	-1.19536900	0.95592200	1.79027400
C	1.77885100	0.52961400	3.27913000
H	3.64764900	0.19820700	2.23702200
H	2.18373900	0.46035200	4.28716900
C	-0.56341000	0.58633200	4.32712300
O	-1.71646400	0.19251300	4.00698100
O	-0.08391700	0.83031100	5.44889000
C	-0.56614200	4.00328600	-1.76896000
H	-1.36957500	4.07184900	-2.50666500
H	-0.36048200	4.97938800	-1.31591000
H	0.35705500	3.67799300	-2.26954800
C	-0.88344900	2.98477700	-0.72900800
H	0.34661200	0.81414300	-1.94986700
H	-0.19482800	2.92000700	0.13689600

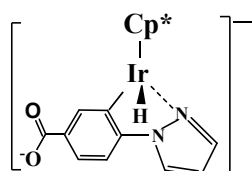


**54**

**E=-1293.185134(au)**

C	-0.51822600	-2.20989600	-1.28151900
C	-1.33526700	-1.60658300	-2.32551900
C	-2.45157200	-1.00984600	-1.69414200
C	-1.24499100	-2.07229200	-0.02565500
C	-2.41782000	-1.31739700	-0.26989800
Ir	-0.53566000	-0.10959300	-0.83177100
C	-1.02121800	-1.64478300	-3.78226600
H	-1.31631400	-2.60397000	-4.23374000
H	-1.53652400	-0.84500700	-4.32573800
H	0.05308800	-1.51269900	-3.95132200
C	0.63527600	-3.12168300	-1.52214100
H	1.32152800	-3.12613800	-0.67067200
H	0.28956300	-4.14964600	-1.71334200
H	1.21995100	-2.79031100	-2.38809700
C	-0.78311600	-2.62726500	1.27830200
H	-1.11689800	-2.01373500	2.12169900
H	-1.15807700	-3.64986300	1.42506300
H	0.31107600	-2.65524600	1.31921100
C	-3.43957700	-0.86511100	0.71833200
H	-3.61706600	0.21576200	0.64233400
H	-4.40491400	-1.37162200	0.57153100
H	-3.11319200	-1.05952800	1.74515000
C	-3.53917300	-0.22034400	-2.33912700
H	-3.29857600	0.02266400	-3.37961000
H	-4.48727500	-0.77711000	-2.33229000
H	-3.70988400	0.72392100	-1.80830500
C	3.52108900	0.72068600	-0.95630800
C	4.17799000	-0.13938100	-1.81203900
C	3.81578400	-1.41611400	-1.34684900
N	3.00762500	-1.35258800	-0.29076400
H	3.46370000	1.80088200	-0.90657000
H	4.81773700	0.11951700	-2.64469300
H	4.11504000	-2.38606300	-1.73075400
N	2.83937000	-0.03943400	-0.06843600
C	0.58328100	0.42048700	0.82103400
C	1.97794300	0.45506500	0.96640700

C	-0.13430500	0.99182900	1.89210600
C	2.60594600	1.04244700	2.06976100
C	0.46151000	1.64699400	2.97042300
H	-1.22536200	1.02445000	1.86258800
C	1.85308500	1.64465900	3.06656000
H	3.69582700	1.03181900	2.11252200
H	2.30664700	2.13290700	3.92663900
C	-0.38608300	2.44869100	3.97195400
O	-1.52254500	2.79726500	3.54086600
O	0.14712300	2.69755000	5.06529400
C	-1.47527000	3.92348800	0.71282800
H	-2.51564900	4.01375900	0.38749600
H	-1.47882600	3.57724200	1.78719400
H	-0.95100900	4.88308200	0.67222000
C	-0.77360700	2.86971500	-0.02895500
H	0.71859100	0.49030200	-1.64950800
H	0.33266800	2.87607400	-0.01609500
O	-1.36460200	1.94825400	-0.59997200



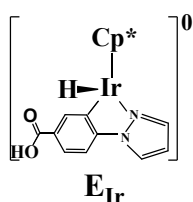
11

47

**E=-1139.396374(au)**

C	-0.58796000	-2.48986700	-1.33947300
C	-1.31709200	-1.79691000	-2.37930100
C	-2.24623400	-0.95930800	-1.71057100
C	-1.24934900	-2.24106800	-0.05206000
C	-2.24983900	-1.28199000	-0.27573800
Ir	-0.23038300	-0.44068400	-0.93577500
C	-1.04529300	-1.86910200	-3.84290500
H	-1.59044700	-2.69520800	-4.32189100
H	-1.33463800	-0.93990600	-4.34620300
H	0.02337300	-2.01442100	-4.03650200
C	0.51158700	-3.47401200	-1.53345800
H	1.28046200	-3.34393900	-0.76351800
H	0.12614900	-4.50308800	-1.48394100
H	0.99906100	-3.33364400	-2.50425600
C	-0.82625100	-2.84724700	1.24038700
H	-1.19175400	-2.26677700	2.09296200
H	-1.19777600	-3.87691700	1.33866100
H	0.26758200	-2.87156600	1.31227200
C	-3.16281700	-0.65971000	0.72274600

H	-3.29929500	0.40971000	0.52377900
H	-4.15607200	-1.12970700	0.69354900
H	-2.77933100	-0.73309500	1.74583100
C	-3.17881900	0.01873100	-2.33464300
H	-2.83907700	0.31592200	-3.33189300
H	-4.18976300	-0.40345600	-2.42770200
H	-3.25441900	0.92706300	-1.72650300
C	3.91727300	0.65781500	-0.84192600
C	4.51429400	-0.22315000	-1.72078600
C	3.88423400	-1.45000400	-1.44837600
N	2.97748100	-1.34098900	-0.48008900
H	4.04130300	1.72011200	-0.67579000
H	5.28409600	-0.00756000	-2.44919500
H	4.05499900	-2.41756900	-1.90928600
N	3.01201700	-0.04472100	-0.12144300
C	0.72895500	0.37034300	0.66762500
C	2.11551500	0.48348100	0.86160400
C	-0.07330000	0.85336800	1.71641100
C	2.66231700	1.07394300	1.99933000
C	0.43954100	1.45283800	2.86370400
H	-1.15987800	0.79585000	1.67515600
C	1.82220400	1.57275400	2.99034900
H	3.74767000	1.10668600	2.10690500
H	2.20165300	2.03244100	3.90120400
C	-0.52158600	1.91242800	3.98746300
O	-1.72753100	1.64304300	3.78677600
O	0.03291900	2.47847400	4.95154900
H	0.85266800	0.32156800	-1.88535900



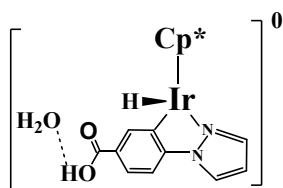
**48**

**E=-1139.884306(au)**

C	-1.27237100	-2.07532600	2.30478000
C	-1.81077100	-1.10966100	1.35820400
C	-2.77423300	-0.31965100	2.04034500
C	-1.90022600	-1.86842100	3.55660400
C	-2.79641300	-0.73166300	3.42734400
Ir	-0.80692600	0.07995800	3.03487400
C	-1.49500600	-1.06747300	-0.09929200
H	-2.15987300	-1.72649400	-0.67518100
H	-1.60005000	-0.05509600	-0.50552300



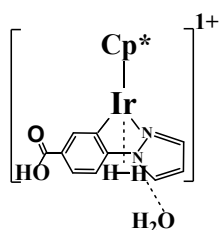
H	-0.46912600	-1.40047500	-0.29619800
C	-0.25232400	-3.10763600	1.96302700
H	0.17597100	-3.56316100	2.86152600
H	-0.68539200	-3.91280000	1.35398400
H	0.57713500	-2.67612900	1.38793900
C	-1.69058800	-2.63952200	4.81354400
H	-1.61335100	-1.97360000	5.68184000
H	-2.52680200	-3.32629100	4.99992400
H	-0.77093300	-3.23244900	4.77475300
C	-3.78006400	-0.27242100	4.45171000
H	-3.91879700	0.81362500	4.41517200
H	-4.76215000	-0.74293900	4.30345200
H	-3.45094300	-0.52407900	5.46587900
C	-3.65145100	0.72775200	1.44424600
H	-3.18537600	1.19625100	0.57116300
H	-4.60961700	0.29627000	1.12381100
H	-3.86716700	1.51998700	2.16826000
C	3.24782500	1.09765700	3.02134700
C	3.22064700	0.88732500	1.65994100
C	1.90236600	0.50207000	1.37338500
N	1.17737600	0.47432800	2.49004400
H	4.04734700	1.41140500	3.67742600
H	4.04002800	1.00116100	0.96534300
H	1.43880400	0.25956900	0.42562400
N	2.00422400	0.83996600	3.49711500
C	0.05652500	0.56881800	4.81690600
C	1.42909700	0.88577300	4.78664500
C	-0.53378700	0.62101800	6.08253500
C	2.17800400	1.22527700	5.90690100
C	0.19128700	0.92630200	7.23669300
H	-1.59992100	0.43223500	6.20119800
C	1.55194600	1.24029900	7.14516700
H	3.23178000	1.48450600	5.82432000
H	2.12347900	1.55239800	8.01818200
H	-0.96735400	1.67324300	2.96607000
C	-0.54773800	0.93371000	8.53030100
O	-1.74450400	1.03730000	8.62058800
O	0.20467200	0.80435900	9.64862800
H	1.10917800	0.56970500	9.40875300



**EIr'****51****E=-1216.323131(au)**

C	-1.07494700	-2.13244100	2.66115500
C	-1.60939500	-1.37324800	1.54090300
C	-2.70145000	-0.59865600	2.01630500
C	-1.83067900	-1.81145800	3.81434400
C	-2.81164000	-0.80511200	3.44566900
Ir	-0.87831800	0.14412300	3.08532900
C	-1.14372800	-1.49607600	0.12910200
H	-1.62430100	-2.34042800	-0.38463600
H	-1.36218900	-0.58956200	-0.44614200
H	-0.06095500	-1.66721400	0.08042800
C	0.06208900	-3.09106600	2.55610800
H	0.41847800	-3.40267100	3.54302900
H	-0.22653100	-3.99573400	2.00367300
H	0.91501300	-2.64633800	2.02673300
C	-1.67086500	-2.37020300	5.18615300
H	-1.71038300	-1.57884600	5.94510900
H	-2.47129000	-3.08567800	5.41672800
H	-0.71336900	-2.88911000	5.30131600
C	-3.91921400	-0.30861300	4.31348700
H	-4.18525300	0.72546000	4.06888900
H	-4.82260300	-0.92489300	4.20422200
H	-3.63931700	-0.32856100	5.37262400
C	-3.60943300	0.26051200	1.20369200
H	-3.11238700	0.63619000	0.30348100
H	-4.49932900	-0.30136300	0.88898100
H	-3.94824300	1.12896400	1.77765500
C	3.02796300	1.62596000	3.12795900
C	3.12404200	1.20140200	1.82003100
C	1.88271900	0.61472200	1.53157500
N	1.08705600	0.67486800	2.59803200
H	3.73620700	2.13705300	3.76471300
H	3.97362100	1.30552800	1.16111300
H	1.51555700	0.17056300	0.61467200
N	1.79074800	1.29399700	3.57260900
C	-0.20133800	0.98378700	4.81751300
C	1.12348400	1.46354100	4.80664900
C	-0.88171300	1.15036500	6.02858000
C	1.74557300	2.06542600	5.89488300
C	-0.27982700	1.71180000	7.15574400
H	-1.92596000	0.85164200	6.11874000
C	1.03607100	2.18683100	7.08336400

H	2.76061500	2.45231500	5.82152300
H	1.49129600	2.68482400	7.93714100
H	-1.19257700	1.68410400	2.77719200
C	-1.10269400	1.83787800	8.39884900
O	-2.30356900	1.96334500	8.36942800
O	-0.43827000	1.80742500	9.56263800
H	0.45744500	1.42062500	9.46368600
O	1.90632500	0.32187300	9.25848300
H	1.63911400	-0.57415000	9.48438200
H	1.99358300	0.33420900	8.29689600



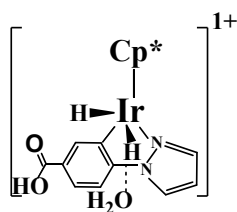
12

52

**E=-1216.762451(au)**

C	-1.06481300	-1.79203200	2.69625900
C	-1.60022200	-1.07556800	1.53603100
C	-2.72041700	-0.33238000	1.96799500
C	-1.94889300	-1.55564600	3.80733700
C	-2.90986600	-0.57323500	3.39674500
Ir	-0.90117500	0.32040900	3.17989000
C	-1.05819800	-1.14662300	0.15106600
H	-1.56635800	-1.93373500	-0.41979000
H	-1.19576200	-0.20152400	-0.38507000
H	0.00982400	-1.38655800	0.14834700
C	0.08705300	-2.73701100	2.67132100
H	0.52183600	-2.85909300	3.66866400
H	-0.22200400	-3.72788600	2.31625800
H	0.88094600	-2.37634400	2.00781800
C	-1.87413300	-2.22553300	5.13190400
H	-2.32268700	-1.63617200	5.93678400
H	-2.42083800	-3.17583500	5.07999600
H	-0.84390000	-2.45258200	5.42081500
C	-4.04602200	-0.05908700	4.21318700
H	-4.32709400	0.95638900	3.91661300
H	-4.93039000	-0.69710500	4.09101700
H	-3.79828600	-0.03655900	5.27900000
C	-3.59633300	0.53816700	1.13660300
H	-3.10932500	0.83376500	0.20307600
H	-4.51881500	0.00365100	0.87658900

H	-3.89019300	1.44613300	1.67429600
C	3.25175600	0.86100200	2.99805000
C	3.10511600	0.96233900	1.62926600
C	1.72796600	0.86055400	1.39720700
N	1.08182900	0.70403600	2.55285800
H	4.13436100	0.89406600	3.62180500
H	3.88870800	1.09328200	0.89749300
H	1.16876000	0.90737900	0.47094500
N	2.01893900	0.70489500	3.53071500
C	0.14061900	0.50288500	4.96099700
C	1.53558700	0.60570200	4.85632900
C	-0.38360900	0.44074200	6.24349800
C	2.38320100	0.61230000	5.95729800
C	0.43715800	0.44113000	7.37431800
H	-1.45788400	0.37894100	6.40715000
C	1.82298200	0.52035600	7.22582100
H	3.46270200	0.67052300	5.83878300
H	2.48615400	0.47117400	8.08753400
H	-1.23146500	2.01048300	3.59494600
C	-0.24961900	0.26732900	8.69149400
O	-1.34032200	-0.23606100	8.77922500
O	0.40776800	0.68582300	9.78508800
O	-0.80288900	2.90272100	0.80015700
H	-0.04329400	3.49396600	0.77714900
H	-1.51068500	3.40185100	0.37982800
H	-1.10605200	2.03218900	2.73964500
H	1.18464700	1.20807100	9.55096300



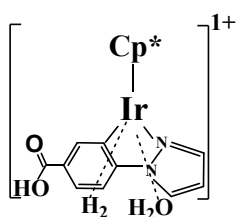
12'

52

E=-1216.752397(au)

C	-0.61375900	-1.97607400	-1.27313100
C	-1.26571800	-1.13943000	-2.25543000
C	-2.30050900	-0.39741900	-1.57889100
C	-1.22201800	-1.74626100	-0.00752700
C	-2.24551100	-0.73466800	-0.17635100
Ir	-0.37259700	0.30700500	-0.77538300
C	-1.02252400	-1.15745700	-3.72682500
H	-1.68346900	-1.88266300	-4.21749600

H	-1.20214800	-0.17668200	-4.17790800
H	0.00670100	-1.44656100	-3.96287700
C	0.51631800	-2.90934300	-1.53216700
H	1.20542300	-2.94701300	-0.68130000
H	0.14729500	-3.92812500	-1.70321300
H	1.09155100	-2.61670500	-2.41615400
C	-0.88867200	-2.44554500	1.26226200
H	-1.12281900	-1.84484100	2.14764200
H	-1.46675500	-3.37553800	1.33440500
H	0.17195500	-2.71311500	1.31206500
C	-3.24496900	-0.30853100	0.84627700
H	-3.44997400	0.76563800	0.79216600
H	-4.19404900	-0.83449300	0.68238400
H	-2.92160700	-0.53983100	1.86612300
C	-3.33265000	0.46841700	-2.21384700
H	-2.98028600	0.88806600	-3.16066800
H	-4.23590700	-0.11847900	-2.42318300
H	-3.61949400	1.29664700	-1.55865400
C	3.79418800	0.70667600	-0.67779000
C	3.74325600	0.63945300	-2.05483700
C	2.38425600	0.52602500	-2.37234300
N	1.65838900	0.52210800	-1.25416200
H	4.63113800	0.80526900	-0.00024800
H	4.57782000	0.67238000	-2.73957400
H	1.89408900	0.45342200	-3.33548400
N	2.52345200	0.63190200	-0.21842300
C	0.54258900	0.60633300	1.06824700
C	1.94296600	0.65405400	1.06669300
C	-0.08872100	0.63867500	2.29937000
C	2.69773100	0.69980600	2.23276100
C	0.63882000	0.65445400	3.49117600
H	-1.17320300	0.62643400	2.37432600
C	2.03340200	0.68865900	3.45412200
H	3.78445900	0.71559100	2.19855800
H	2.62152800	0.65986700	4.36944100
C	-0.16146700	0.51365900	4.74591200
O	-1.24543400	-0.01350100	4.74510700
O	0.38256000	0.97678500	5.88108600
H	-0.72793700	1.79299200	-0.32876800
H	-0.44763200	1.42848500	-1.90606400
H	1.16542100	1.51325900	5.70576600
O	-0.33964000	2.64446800	-3.65765700
H	0.40536600	3.25343600	-3.65730100
H	-1.10327200	3.19651900	-3.85283200



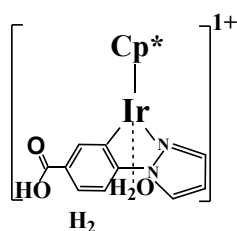
TS<sub>12-13</sub>

52 -103.60i cm<sup>-1</sup>

E=-1216.759876(au)

C	-0.79659900	-2.11022500	-1.07578200
C	-1.17280800	-1.30036500	-2.23070300
C	-2.12601100	-0.36199700	-1.79393000
C	-1.64068000	-1.72487000	0.05013200
C	-2.39570800	-0.59546400	-0.36853300
Ir	-0.26080400	-0.14154300	-0.51309900
C	-0.58818000	-1.42859600	-3.59365400
H	-1.08847500	-2.22430400	-4.15909900
H	-0.69180700	-0.49882800	-4.16242300
H	0.47697000	-1.68292400	-3.54867600
C	0.13701100	-3.26413100	-1.09049400
H	0.58890800	-3.42094400	-0.10629300
H	-0.40217900	-4.18136300	-1.36348400
H	0.94266400	-3.12171100	-1.81744100
C	-1.71269500	-2.44260600	1.35049800
H	-2.18048000	-1.83846500	2.13312400
H	-2.31853900	-3.35020500	1.23466500
H	-0.72434000	-2.74859100	1.70830600
C	-3.37907200	0.17528800	0.43953400
H	-3.30588300	1.24914100	0.23796700
H	-4.40374900	-0.13697800	0.20023100
H	-3.22563300	0.02794900	1.51252700
C	-2.78044100	0.69323700	-2.60800600
H	-2.18848600	0.94127300	-3.49287700
H	-3.76822400	0.34759300	-2.94013200
H	-2.93226700	1.61202900	-2.03229000
C	3.61345400	1.35629800	-0.83592000
C	3.43692900	1.31051000	-2.20716200
C	2.14797500	0.80382000	-2.39293900
N	1.57692500	0.56121300	-1.21070900
H	4.46011000	1.67481200	-0.24311700
H	4.15183000	1.59496500	-2.96514700
H	1.59029800	0.62101400	-3.30281300
N	2.48124600	0.90203200	-0.26062400

C	0.76185000	0.22517200	1.23364500
C	2.06497000	0.73566900	1.08477400
C	0.31362900	0.07203200	2.54169000
C	2.89156900	1.05867900	2.15038000
C	1.10426200	0.41312600	3.64288300
H	-0.67825400	-0.32280500	2.75212200
C	2.39927300	0.89159700	3.44029200
H	3.90281700	1.42758200	1.99604200
H	3.05889800	1.10583400	4.27938400
C	0.50666400	0.17997800	4.99525900
O	-0.43027500	-0.55702400	5.16283200
O	1.06262200	0.83136800	6.03040000
H	-0.66534700	2.43722700	-0.00382100
H	-0.55508000	2.53878200	-0.74140700
H	1.68347700	1.50766100	5.73436900
O	-0.18252100	2.64711900	-3.21659500
H	0.59365000	3.20970900	-3.13253200
H	-0.83893200	3.20927600	-3.64000600



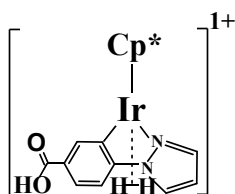
13

52

E=-1216.761384(au)

C	-1.12857700	-1.88182400	2.59710600
C	-1.54280500	-1.17469900	1.38189400
C	-2.55640000	-0.26568500	1.73738900
C	-2.01758600	-1.47589400	3.66992000
C	-2.83062400	-0.41327800	3.16937900
Ir	-0.72188800	0.15848100	3.02110300
C	-0.95884400	-1.39406800	0.03022800
H	-1.48486500	-2.20759000	-0.48488100
H	-1.03581300	-0.50258400	-0.60110200
H	0.09607500	-1.68353300	0.08765900
C	-0.13921200	-2.99274700	2.65745500
H	0.25194500	-3.11921400	3.67180700
H	-0.59747900	-3.94200500	2.35155300
H	0.71307200	-2.80492100	1.99570800
C	-2.07111900	-2.09291500	5.02161600
H	-2.55938000	-1.44878800	5.75880300
H	-2.64633600	-3.02598300	4.97081000

H	-1.07367100	-2.33737600	5.40017700
C	-3.89955900	0.32576700	3.89520700
H	-3.94567600	1.37140200	3.57062500
H	-4.88113100	-0.12463600	3.69890800
H	-3.74031700	0.31903800	4.97777400
C	-3.24478600	0.72111400	0.86299600
H	-2.76009700	0.81647000	-0.11275400
H	-4.28543500	0.41872500	0.69031000
H	-3.26883600	1.71246200	1.33004700
C	3.39748100	0.92539200	2.78835900
C	3.26096700	0.86813900	1.41610900
C	1.89953400	0.63154800	1.19403300
N	1.24906400	0.55123400	2.35726400
H	4.26977500	1.08752600	3.40658400
H	4.04061500	0.97983000	0.67708500
H	1.35939500	0.51122600	0.26280400
N	2.17406800	0.73420500	3.33079400
C	0.31519300	0.44885100	4.78051800
C	1.69431700	0.69747800	4.66315200
C	-0.19261500	0.44346100	6.07513800
C	2.53675300	0.89017500	5.75061700
C	0.61896800	0.64497000	7.19626000
H	-1.25132700	0.27112600	6.25878200
C	1.98858800	0.85368600	7.02758200
H	3.60406700	1.05335200	5.61994400
H	2.65699800	0.95515100	7.88079200
H	-2.70872800	2.75306900	5.92849800
C	-0.05924900	0.55700300	8.52840000
O	-1.14001300	0.04279900	8.66025200
O	0.58732700	1.07571400	9.58463100
O	-0.90943700	2.47333300	3.04796900
H	-0.68039100	2.79081000	3.93398500
H	-0.28971200	2.89652400	2.43868600
H	-2.61114000	2.86450300	5.19784000
H	1.36372400	1.58142600	9.31666900



14

49

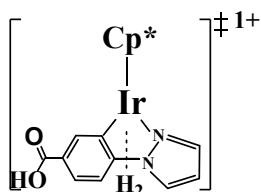
**E=-1140.326979(au)**

C	-0.60749900	-1.86246200	-1.01836900
---	-------------	-------------	-------------



C	-1.08095200	-1.25194600	-2.26208400
C	-2.21930000	-0.47165000	-1.96207200
C	-1.56000700	-1.54008400	0.01634500
C	-2.48834100	-0.59821100	-0.53075100
Ir	-0.45528900	0.27457000	-0.69738100
C	-0.45757000	-1.45919400	-3.59668400
H	-0.82932800	-2.39015000	-4.04297600
H	-0.69044600	-0.64603200	-4.29116000
H	0.63097000	-1.55104400	-3.52391400
C	0.51654800	-2.83234900	-0.89412400
H	0.93408900	-2.82269300	0.11820800
H	0.18022000	-3.85465600	-1.10799700
H	1.32771200	-2.59817000	-1.59163900
C	-1.58174900	-2.12563100	1.38203500
H	-2.15437100	-1.52535700	2.09459400
H	-2.05825500	-3.11331600	1.33151600
H	-0.57731100	-2.26535200	1.79248500
C	-3.65629700	-0.00196200	0.17699500
H	-3.91030400	0.98402900	-0.22441100
H	-4.54055500	-0.64180700	0.06513000
H	-3.46314100	0.11472800	1.24768600
C	-3.04593700	0.32101900	-2.91434800
H	-2.48722500	0.59115200	-3.81508700
H	-3.92351700	-0.25843400	-3.22768000
H	-3.41409000	1.24597800	-2.45918800
C	3.66438900	0.98475900	-1.04041100
C	3.45781500	1.09206100	-2.40052800
C	2.08110100	0.91626900	-2.57848600
N	1.49065400	0.71037200	-1.40045600
H	4.56884300	1.06196800	-0.45319000
H	4.20219900	1.27641600	-3.16095700
H	1.49116000	0.93376900	-3.48636900
N	2.46503400	0.75391300	-0.46032400
C	0.65793200	0.46483400	1.04433200
C	2.04203900	0.61977600	0.88156900
C	0.18791300	0.37464700	2.34493100
C	2.93239700	0.64602400	1.94812900
C	1.05360100	0.39295500	3.44202400
H	-0.87511100	0.27265800	2.55224500
C	2.42786900	0.52190500	3.23738000
H	4.00355600	0.74303600	1.78759900
H	3.12731800	0.48772900	4.07061800
C	0.42385800	0.17507600	4.78186600
O	-0.64542400	-0.36695000	4.89820700

O	1.10739700	0.59440300	5.85776200
H	-0.82629000	1.92474900	-0.17765900
H	-0.72975000	1.99391800	-1.03434500
H	1.85743700	1.14804500	5.60869700



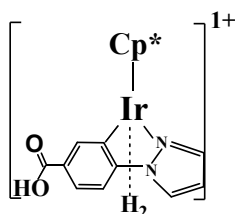
TS<sub>14-15</sub>

49 -161.72i cm<sup>-1</sup>

E=-1140.32429(au)

C	-0.74962900	-2.10988000	-1.01517500
C	-1.12760000	-1.36980100	-2.21946000
C	-2.10634400	-0.42950000	-1.84931600
C	-1.62787600	-1.68972500	0.06999600
C	-2.39620900	-0.59685000	-0.41830400
Ir	-0.26032900	-0.10787400	-0.54939500
C	-0.53821100	-1.58488200	-3.56887000
H	-1.05511000	-2.40210100	-4.08721100
H	-0.62160600	-0.69352500	-4.19902900
H	0.51971100	-1.86223100	-3.50591800
C	0.20308300	-3.24802400	-0.96212900
H	0.59614400	-3.39089900	0.04890900
H	-0.29832600	-4.17741200	-1.26386600
H	1.05151400	-3.09192600	-1.63589700
C	-1.71582700	-2.34566400	1.40151200
H	-2.22987900	-1.72434800	2.14023000
H	-2.28541900	-3.27903600	1.30851600
H	-0.72946400	-2.59931000	1.80320000
C	-3.41630600	0.18224600	0.33516800
H	-3.43361000	1.23152200	0.02230400
H	-4.41871800	-0.22969200	0.16118300
H	-3.22905700	0.15914000	1.41291100
C	-2.76119700	0.57762200	-2.72527700
H	-2.16710300	0.79357000	-3.61805900
H	-3.73983100	0.20899600	-3.05897300
H	-2.93531200	1.52180700	-2.19929300
C	3.68822700	1.21481000	-0.85657200
C	3.52187500	1.17205500	-2.22782000
C	2.21419000	0.72178700	-2.42210800
N	1.62124900	0.50529900	-1.24430600
H	4.54146200	1.50231700	-0.25751400
H	4.25091500	1.42956800	-2.98168600

H	1.67028600	0.54809100	-3.34230200
N	2.53264400	0.81065100	-0.28861800
C	0.77200800	0.23720900	1.19908300
C	2.10180500	0.67158100	1.05415100
C	0.30659800	0.11905400	2.50357400
C	2.93985300	0.94861300	2.12444400
C	1.11097300	0.41266400	3.60847900
H	-0.70926100	-0.21063100	2.71016200
C	2.43329900	0.81240100	3.41230000
H	3.97198600	1.25590400	1.97394500
H	3.10105000	0.98743100	4.25395300
C	0.49294700	0.20591800	4.95624900
O	-0.48124200	-0.48419700	5.11203700
O	1.07370700	0.82185500	5.99843200
H	-0.64803300	2.27394900	-0.08046700
H	-0.53210500	2.38503000	-0.81836700
H	1.73181700	1.46628200	5.71175900



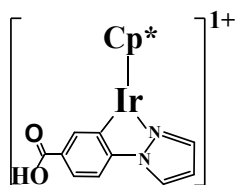
15

49

**E=-1140.320498(au)**

C	-1.20134700	-2.07120400	-1.18377200
C	-1.36785800	-1.23306400	-2.35154700
C	-2.06988600	-0.07633900	-1.93780900
C	-1.90911100	-1.47867000	-0.06293600
C	-2.40579200	-0.22010900	-0.51190200
Ir	-0.25307000	-0.19242200	-0.66866700
C	-0.83620400	-1.53899600	-3.70860000
H	-1.47719400	-2.26558800	-4.22254200
H	-0.79137800	-0.64473200	-4.33797700
H	0.17034200	-1.96991100	-3.65960600
C	-0.50992800	-3.38254400	-1.14764000
H	-0.06720300	-3.57397400	-0.16521600
H	-1.23269000	-4.18582800	-1.34677400
H	0.27951000	-3.45131500	-1.90174600
C	-2.10770200	-2.12934800	1.26106200
H	-2.48562300	-1.42915500	2.01155300
H	-2.83987400	-2.94162000	1.17496400
H	-1.17660000	-2.55981100	1.64504500

C	-3.19035700	0.77004700	0.27025300
H	-2.88629400	1.79520400	0.03183000
H	-4.25934100	0.67774200	0.03858200
H	-3.06494600	0.62718800	1.34723100
C	-2.43099400	1.10320100	-2.76587900
H	-1.80582700	1.17918700	-3.66079600
H	-3.47656500	1.03483600	-3.09307000
H	-2.32567600	2.03509600	-2.20036600
C	3.31676300	1.87989000	-1.07955700
C	3.13429400	1.77977200	-2.44857300
C	1.96396000	1.03807300	-2.60361500
N	1.46636900	0.70365300	-1.40662200
H	4.09220900	2.37040900	-0.50671500
H	3.76780500	2.18856200	-3.22163300
H	1.45094600	0.72578200	-3.50506200
N	2.30559900	1.22460700	-0.47853000
C	0.70467100	0.36627000	1.05496300
C	1.93532700	1.02834300	0.87751500
C	0.30093200	0.17057700	2.37329400
C	2.73786000	1.45320300	1.92405100
C	1.06838900	0.60424300	3.45739400
H	-0.63197600	-0.34033500	2.60289000
C	2.29248700	1.23230900	3.22412700
H	3.69784100	1.93388600	1.75133800
H	2.94034900	1.52641800	4.04808300
C	0.52969300	0.30336300	4.82237100
O	-0.33020500	-0.51974200	5.00017900
O	1.04763800	0.99007800	5.85315600
H	0.13860100	3.26924300	-0.63889500
H	0.25623000	3.39134500	-1.36578100
H	1.59498600	1.72722300	5.55770600



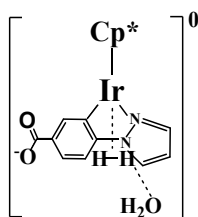
16

47

**E=-1139.148791(au)**

C	-1.16707700	-2.03426500	-1.19307200
C	-1.37502300	-1.19466100	-2.35449500
C	-2.11772700	-0.07019100	-1.92840600
C	-1.89165100	-1.47595600	-0.06410100
C	-2.43770600	-0.23511400	-0.50189100

Ir	-0.27990600	-0.13586000	-0.66817700
C	-0.84255000	-1.47169000	-3.71727300
H	-1.45779100	-2.22108500	-4.22991900
H	-0.83759100	-0.57289200	-4.34183500
H	0.18061600	-1.86258000	-3.67858900
C	-0.42567200	-3.31847100	-1.17627400
H	-0.01209800	-3.52920100	-0.18541000
H	-1.10505300	-4.14228400	-1.43498800
H	0.39427800	-3.32471400	-1.90078800
C	-2.06159000	-2.14016000	1.25715600
H	-2.44918000	-1.45412300	2.01578200
H	-2.77523600	-2.96881400	1.17200500
H	-1.11742400	-2.55027400	1.63113500
C	-3.26587000	0.71281300	0.28729900
H	-3.02171100	1.75259500	0.04594800
H	-4.33003600	0.56142400	0.06396500
H	-3.12632800	0.57740500	1.36343800
C	-2.53143600	1.09924200	-2.74563700
H	-1.94030600	1.18527600	-3.66222700
H	-3.58657000	1.00852400	-3.03449500
H	-2.42591400	2.03442800	-2.18560400
C	3.40275700	1.73870400	-1.07547300
C	3.21751100	1.64888800	-2.44462400
C	1.98282800	1.02069400	-2.60177900
N	1.44931300	0.74342000	-1.40568300
H	4.21956400	2.15527000	-0.50160300
H	3.88860700	1.99459800	-3.21672800
H	1.44594400	0.75271800	-3.50355400
N	2.32929900	1.18945800	-0.47565400
C	0.69130700	0.39697900	1.05432400
C	1.94603600	1.01290500	0.87942900
C	0.27416400	0.22399500	2.37160200
C	2.75755600	1.41556000	1.92783200
C	1.04974300	0.63909300	3.45686100
H	-0.67681600	-0.25306800	2.59942900
C	2.29724700	1.22056700	3.22671300
H	3.73359600	1.86362700	1.75764500
H	2.94948000	1.49790700	4.05301100
C	0.49288100	0.36970800	4.82093400
O	-0.38988500	-0.42799400	5.00252600
O	1.02170900	1.05591500	5.84662000
H	1.58804000	1.77613900	5.54506200



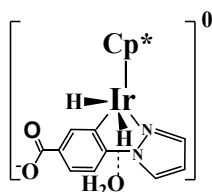
17

51

**E=-1216.301109(au)**

C	-0.99744300	-1.74069500	2.65040300
C	-1.68149000	-1.06350800	1.54998300
C	-2.76416100	-0.34574400	2.11681700
C	-1.73686200	-1.51820200	3.86055800
C	-2.78032400	-0.57715700	3.55764200
Ir	-0.86287800	0.41291000	3.05952800
C	-1.31762300	-1.14620200	0.10653000
H	-1.85227700	-1.96489500	-0.39289100
H	-1.55776500	-0.21644600	-0.42107800
H	-0.24631100	-1.33394700	-0.02591200
C	0.19417900	-2.62503800	2.51201500
H	0.74932300	-2.68868300	3.45396700
H	-0.10330000	-3.64287300	2.22965300
H	0.88390300	-2.25331300	1.74609200
C	-1.44916000	-2.13528600	5.18472000
H	-1.80239400	-1.54720800	6.04278700
H	-1.93031200	-3.12152300	5.22722700
H	-0.37352300	-2.28457100	5.33180500
C	-3.83198200	-0.10683800	4.50574100
H	-4.13226600	0.92459300	4.29238700
H	-4.72790200	-0.73673000	4.42909100
H	-3.48953800	-0.14667800	5.54613900
C	-3.74716400	0.50251900	1.38689700
H	-3.32856500	0.89613300	0.45511800
H	-4.64402400	-0.07938600	1.13828900
H	-4.06959200	1.35224500	1.99809400
C	3.30166700	0.78365500	3.09173600
C	3.24686000	0.76738200	1.70649000
C	1.88744600	0.70769800	1.39549600
N	1.16298800	0.69280000	2.52161900
H	4.13864000	0.83186800	3.77469800
H	4.08134600	0.79530800	1.02123800
H	1.38698400	0.67081900	0.43460600
N	2.03722400	0.73524100	3.55360800
C	0.07322900	0.75124600	4.86323100

C	1.46976200	0.72244200	4.85682500
C	-0.57179900	0.70588400	6.08226100
C	2.21664600	0.62867700	6.03087800
C	0.13318000	0.50329400	7.26442200
H	-1.65586400	0.70128800	6.17209700
C	1.52936900	0.50712000	7.23537800
H	3.30607700	0.60897200	6.00182900
H	2.04673900	0.37402400	8.18337500
H	-1.16016900	2.11010100	3.33835400
C	-0.67712100	0.10144900	8.52064800
O	-1.85570600	-0.23993800	8.25279600
O	-0.04457400	0.12366900	9.58635800
O	-0.76880900	2.93338200	0.51643700
H	0.15419500	3.18405300	0.62334000
H	-1.21638000	3.74635900	0.26278900
H	-1.06075600	2.04733900	2.46823500



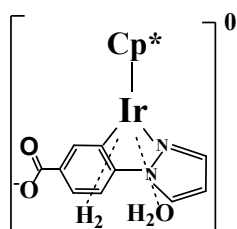
17'

51

E=-1216.291045(au)

C	-0.55003700	-1.91574900	-1.03496500
C	-1.29783900	-1.23111400	-2.05870500
C	-2.34862400	-0.48609500	-1.39993900
C	-1.12274100	-1.61429700	0.23407900
C	-2.21755500	-0.69494000	0.02277100
Ir	-0.44292900	0.42305500	-0.80041800
C	-1.11156200	-1.38108300	-3.53134400
H	-1.65513700	-2.25757500	-3.90686000
H	-1.47158100	-0.50083600	-4.07258300
H	-0.05578200	-1.51149000	-3.79169100
C	0.64920200	-2.77436500	-1.24123300
H	1.39503700	-2.59737200	-0.45684600
H	0.38226300	-3.83812400	-1.20514200
H	1.12575900	-2.58189700	-2.20782500
C	-0.67695700	-2.17658000	1.53810500
H	-1.05449500	-1.62384900	2.41078700
H	-1.02259300	-3.21637400	1.61573400
H	0.41757700	-2.19190500	1.60977200
C	-3.19138300	-0.23782200	1.05793500
H	-3.47494900	0.80925900	0.90466100

H	-4.10643100	-0.84105900	0.99010700
H	-2.80185600	-0.33720400	2.07904700
C	-3.46804900	0.24665200	-2.05766300
H	-3.17616500	0.63544700	-3.03833800
H	-4.32960100	-0.41898500	-2.19741700
H	-3.79616600	1.09229900	-1.44541700
C	3.72343800	0.67858500	-0.74657100
C	3.65762300	0.64259100	-2.12980100
C	2.29577100	0.62818200	-2.43875000
N	1.58156100	0.65503000	-1.30677900
H	4.56557700	0.71199200	-0.06918400
H	4.48786700	0.64203300	-2.82058700
H	1.78390400	0.64654300	-3.39407800
N	2.45985600	0.68292800	-0.27797300
C	0.49320200	0.81899200	1.01400500
C	1.88756000	0.71989400	1.01549400
C	-0.16744900	0.82912800	2.22245200
C	2.61514900	0.61327500	2.19882900
C	0.51600700	0.59078000	3.41171800
H	-1.24903100	0.88303300	2.28738900
C	1.91004900	0.53392500	3.39748400
H	3.70252300	0.54486400	2.18067200
H	2.41322400	0.38148600	4.35028500
C	-0.32073500	0.16725100	4.64053300
O	-1.47284400	-0.23034800	4.32425100
O	0.26502500	0.21024700	5.72917000
H	-0.80673900	1.91321300	-0.38208900
H	-0.61606000	1.38362500	-2.05786900
O	0.26227800	2.27182200	-4.14150600
H	0.50114700	2.86471500	-3.42173800
H	-0.17374800	2.83155500	-4.79010200



TS<sub>17-18</sub>

51 -182.70i cm<sup>-1</sup>

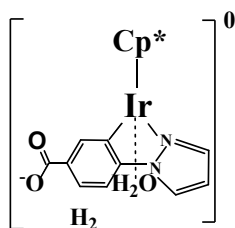
E=-1216.302227(au)

C	-0.69592600	-1.97239000	-1.19117500
C	-1.26603300	-1.17766200	-2.27570300
C	-2.24517200	-0.34228800	-1.70870400
C	-1.46223400	-1.70913400	0.02461100



C	-2.35534100	-0.63747700	-0.27478600
Ir	-0.28961000	0.00771400	-0.57858100
C	-0.83917200	-1.20156700	-3.70371700
H	-1.55886900	-1.75346400	-4.32150000
H	-0.75370700	-0.18742300	-4.10989200
H	0.13080600	-1.69635900	-3.82148400
C	0.34873100	-3.02107700	-1.34170300
H	0.86420600	-3.19959400	-0.39329200
H	-0.09624100	-3.96911800	-1.67156800
H	1.10373300	-2.72799100	-2.07931700
C	-1.33295300	-2.45211400	1.30685100
H	-1.63132800	-1.85554800	2.17460800
H	-1.96579100	-3.34858100	1.27699000
H	-0.30124200	-2.77236100	1.48255800
C	-3.33811800	-0.01366700	0.65534900
H	-3.44883500	1.05822700	0.45806400
H	-4.32771400	-0.47612700	0.54516600
H	-3.03036200	-0.12306600	1.69992800
C	-3.04931000	0.68882500	-2.41625700
H	-2.54844700	1.03907100	-3.32276300
H	-4.02873700	0.27767300	-2.69507200
H	-3.23288200	1.55887700	-1.77685700
C	3.74693800	1.07004800	-0.76080300
C	3.65900000	0.93231600	-2.13873700
C	2.33251600	0.57900800	-2.38313500
N	1.65339200	0.51854700	-1.22614900
H	4.58165400	1.32372200	-0.12200100
H	4.45304400	1.06109500	-2.85943700
H	1.82638500	0.35997600	-3.31658400
N	2.53220800	0.81510200	-0.24248700
C	0.67967400	0.38174300	1.17507100
C	2.02496200	0.77183700	1.08726000
C	0.12523400	0.32601500	2.44686200
C	2.79783200	1.08541300	2.19998400
C	0.87048500	0.60713300	3.58908400
H	-0.91424700	0.06146600	2.63620400
C	2.20521100	0.98934800	3.45643600
H	3.83996100	1.38742000	2.09575200
H	2.75191400	1.19863400	4.37376700
C	0.19639600	0.43616100	4.97804500
O	-0.98337900	0.03077400	4.91629900
O	0.93495700	0.71492200	5.93741300
H	-0.72503200	2.29413800	-0.11667700
H	-0.62358700	2.39829000	-0.86152400

O	-0.18753400	2.39949500	-3.26978000
H	0.67264200	2.35579600	-2.83700300
H	-0.26902200	3.30860500	-3.57263900



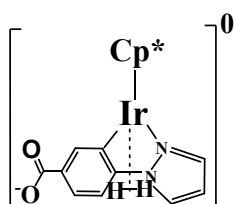
18

51

E=-1216.303975(au)

C	-1.10164800	-1.93535700	2.42308100
C	-1.59582200	-1.17078700	1.27247500
C	-2.58247100	-0.28735200	1.73750600
C	-1.92489900	-1.59571500	3.56870500
C	-2.76204200	-0.50437100	3.17820500
Ir	-0.67246700	0.07084100	2.96378800
C	-1.08774300	-1.31463600	-0.12025500
H	-1.61965100	-2.11646600	-0.64868500
H	-1.21510000	-0.39348400	-0.69871800
H	-0.02330000	-1.57551900	-0.13211700
C	-0.11206500	-3.04674300	2.36059600
H	0.31916900	-3.24050700	3.34775000
H	-0.57967900	-3.97473600	2.00561200
H	0.71480900	-2.80681400	1.68274300
C	-1.89102300	-2.27236800	4.89297900
H	-2.31115100	-1.64610000	5.68468900
H	-2.47915600	-3.19808800	4.84923600
H	-0.86966500	-2.53019800	5.18961700
C	-3.76183000	0.20544600	4.02603600
H	-3.87337200	1.24923600	3.71172300
H	-4.74949500	-0.26839600	3.95293900
H	-3.46992400	0.21352000	5.08209700
C	-3.31935100	0.74865300	0.96351400
H	-2.95254000	0.82752600	-0.06400900
H	-4.38996300	0.51029100	0.92233800
H	-3.22322900	1.73566100	1.43143000
C	3.46071700	0.71286500	2.84382300
C	3.36233300	0.66540100	1.46219500
C	2.00108600	0.50339300	1.20068900
N	1.31409500	0.45858200	2.34922800
H	4.31564300	0.82779700	3.49591000
H	4.16856500	0.73854800	0.74729900

H	1.47723600	0.42198500	0.25620500
N	2.21879500	0.58707100	3.34855100
C	0.31433500	0.33739900	4.73316000
C	1.68767400	0.60996400	4.66830100
C	-0.30176200	0.50301200	5.96625600
C	2.44200000	0.96783000	5.78321100
C	0.40738800	0.91200800	7.09467700
H	-1.37647000	0.38247200	6.10877200
C	1.78668000	1.10137900	7.00302100
H	3.50985600	1.16891100	5.69672200
H	2.30856200	1.39065100	7.91293500
H	-2.12683900	2.57335200	6.57117300
C	-0.37042300	1.22141900	8.39524100
O	-1.61360100	1.28817200	8.22887900
O	0.33524100	1.38297400	9.40057900
O	-0.90221800	2.36856500	3.24546500
H	-1.10330100	2.43913500	4.19725800
H	-0.03233600	2.78057500	3.14892200
H	-2.26849500	2.92982700	5.91406900



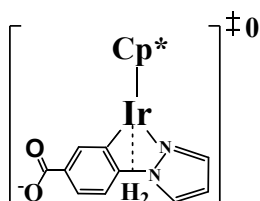
19

48

E=-1139.864877(au)

C	-0.46634300	-1.89373100	-0.94564400
C	-1.13159400	-1.37282900	-2.13787300
C	-2.22689900	-0.59052700	-1.68872400
C	-1.23543200	-1.52713000	0.20982400
C	-2.26765300	-0.63289200	-0.23084900
Ir	-0.33600400	0.29566200	-0.82391900
C	-0.74857500	-1.67112800	-3.54735000
H	-1.16363700	-2.63357900	-3.87410400
H	-1.11420800	-0.90181100	-4.23526500
H	0.33905800	-1.73212600	-3.66636900
C	0.72276500	-2.79232900	-0.92823700
H	1.36873400	-2.56725300	-0.07214200
H	0.41522600	-3.84253700	-0.84705700
H	1.32236600	-2.68917200	-1.83823400
C	-0.98449500	-2.00041600	1.59769400
H	-1.35106700	-1.32878800	2.38751700

H	-1.47876800	-2.97386700	1.72302800
H	0.08537300	-2.15156300	1.78074100
C	-3.33839900	-0.04711100	0.62727700
H	-3.62491600	0.95390400	0.28728000
H	-4.23773000	-0.67631200	0.59917500
H	-3.02359600	0.02919500	1.67438800
C	-3.22183500	0.13572000	-2.52639700
H	-2.84209200	0.34161500	-3.53168800
H	-4.13840100	-0.45976900	-2.62668400
H	-3.50529700	1.08935700	-2.06858600
C	3.83236700	0.62392400	-0.73617800
C	3.80434300	0.49344100	-2.11569600
C	2.45119000	0.41878200	-2.44784900
N	1.70484400	0.49860700	-1.34015500
H	4.65612000	0.72798800	-0.04347900
H	4.65132400	0.46585700	-2.78517000
H	1.97174500	0.31679600	-3.41374200
N	2.55919400	0.62135000	-0.29727600
C	0.57147200	0.80330100	0.96080100
C	1.96590200	0.73357200	0.98751100
C	-0.10393800	0.88235700	2.16009200
C	2.68193500	0.71715900	2.18360000
C	0.56809800	0.75246600	3.37187500
H	-1.18919400	0.91426500	2.21966400
C	1.96365300	0.71245000	3.37661200
H	3.77042500	0.66294800	2.18361200
H	2.45675600	0.63622300	4.34379100
C	-0.28300400	0.44920800	4.62857100
O	-1.45596200	0.09511900	4.34723000
O	0.31594800	0.53970200	5.70860000
H	-0.63663800	2.00656200	-0.67230300
H	-0.49710900	1.87807300	-1.53423200



**TS<sub>19-20</sub>**

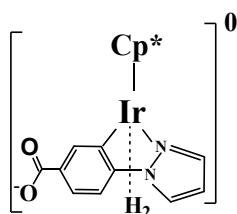
**48 -202.23i cm<sup>-1</sup>**

**E=-1139.865431 (au)**

C	-0.66996800	-2.10403300	-1.08334600
C	-1.21838900	-1.39284300	-2.23586900
C	-2.20275600	-0.51345600	-1.74985600

C	-1.45929200	-1.75159400	0.09314800
C	-2.33750800	-0.70027600	-0.30009700
Ir	-0.25832900	-0.08317200	-0.61998100
C	-0.77060700	-1.56514000	-3.64628200
H	-1.36146000	-2.33708100	-4.15595400
H	-0.87110600	-0.63874000	-4.22219700
H	0.27785300	-1.87907300	-3.69685500
C	0.36383000	-3.17168500	-1.14374400
H	0.83755800	-3.31705600	-0.16844200
H	-0.08346400	-4.12674800	-1.45000000
H	1.15143100	-2.92234800	-1.86353800
C	-1.35693400	-2.40878900	1.42425400
H	-1.71541200	-1.78024700	2.24498400
H	-1.95174400	-3.33152800	1.41865800
H	-0.32243700	-2.67462200	1.66217700
C	-3.33037600	-0.00000200	0.56217300
H	-3.40152600	1.06282300	0.30587400
H	-4.32936300	-0.43949900	0.44332900
H	-3.05853200	-0.06206800	1.62038400
C	-3.00054900	0.46621900	-2.53554300
H	-2.53424100	0.69699700	-3.49830900
H	-4.00387400	0.06711400	-2.73488800
H	-3.13382000	1.40551100	-1.98779000
C	3.76332200	1.02125700	-0.80176800
C	3.67067100	0.89125600	-2.17966800
C	2.35318100	0.50362400	-2.41820700
N	1.68689300	0.40508300	-1.26027600
H	4.59199100	1.30201300	-0.16635600
H	4.45402300	1.05473500	-2.90480200
H	1.84412300	0.29598900	-3.35121300
N	2.56101500	0.72435400	-0.27753800
C	0.69235800	0.35022100	1.12812600
C	2.04810300	0.70068600	1.04893200
C	0.11677200	0.33189900	2.39032900
C	2.81434100	1.00383800	2.16895800
C	0.85621100	0.59606100	3.53932100
H	-0.93315900	0.10660400	2.56783500
C	2.20357500	0.93510800	3.41965400
H	3.86631600	1.27298100	2.07511200
H	2.74799800	1.13201700	4.34106800
C	0.15702600	0.43444300	4.91697300
O	-1.02714600	0.04370200	4.83437300
O	0.88322300	0.69889100	5.88914600
H	-0.44722900	2.31261900	-0.34278000

H	-0.55266800	2.20653300	-1.08589500
---	-------------	------------	-------------



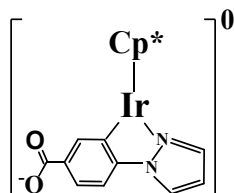
20

48

E=-1139.865558(au)

C	-1.15489100	-2.08148200	-1.40324800
C	-1.40173600	-1.09377600	-2.40514200
C	-2.05070600	0.00221100	-1.75777800
C	-1.76781200	-1.65476100	-0.14514600
C	-2.32304800	-0.36314900	-0.36242300
Ir	-0.18232800	-0.25681500	-0.65096700
C	-0.96643600	-1.15110900	-3.82966900
H	-1.70673800	-1.66619800	-4.45442700
H	-0.83187600	-0.14619700	-4.24567900
H	-0.01583900	-1.68578300	-3.93999600
C	-0.46549900	-3.38474000	-1.58625700
H	0.13444800	-3.63744000	-0.70567100
H	-1.20297500	-4.18730100	-1.72352400
H	0.19460200	-3.38094200	-2.45888500
C	-1.83455000	-2.48299300	1.09030600
H	-2.13971500	-1.89655000	1.96150600
H	-2.55764100	-3.29903900	0.96307800
H	-0.86117400	-2.92743900	1.32454600
C	-3.09113200	0.46832100	0.60421700
H	-2.85716600	1.53167400	0.48598400
H	-4.16967200	0.34022300	0.44506900
H	-2.86787100	0.20493500	1.64241900
C	-2.45528800	1.29055500	-2.37853700
H	-1.84246700	1.52898500	-3.25443400
H	-3.50477600	1.25467500	-2.69991400
H	-2.35493400	2.11595600	-1.66581600
C	3.44745800	1.72929500	-0.96624000
C	3.37597100	1.51860300	-2.33635700
C	2.20312600	0.79108200	-2.52584400
N	1.60309900	0.56978400	-1.34869300
H	4.18071300	2.24824400	-0.36400500
H	4.08067600	1.84931600	-3.08459800
H	1.75604600	0.41103700	-3.43608600
N	2.37575800	1.14843600	-0.40273700

C	0.64955800	0.40420700	1.05467900
C	1.89216500	1.06297000	0.93441100
C	0.11961200	0.30960600	2.34387400
C	2.57749400	1.59367300	2.01375900
C	0.76990900	0.83756000	3.45356100
H	-0.83198600	-0.17462700	2.55864800
C	1.99818800	1.47152000	3.28022400
H	3.53778600	2.09277600	1.88649100
H	2.47280600	1.86560200	4.17741300
C	0.10242300	0.72775100	4.84791800
O	-1.01251900	0.16532200	4.82530600
O	0.77158100	1.21911900	5.77237100
H	0.48669900	3.35244200	-0.83733700
H	0.38056100	3.24026100	-1.56735600



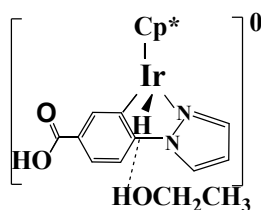
21

46

**E=-1138.694132(au)**

C	-1.11727800	-2.03804400	-1.40379100
C	-1.41555900	-1.06540500	-2.40946500
C	-2.10872200	0.00035400	-1.76361900
C	-1.74272400	-1.63259300	-0.14391700
C	-2.35003100	-0.36549600	-0.36408600
Ir	-0.21109700	-0.18596400	-0.66240000
C	-0.98583500	-1.10788300	-3.83626800
H	-1.72730500	-1.61769300	-4.46396100
H	-0.85177000	-0.09887700	-4.24274700
H	-0.03528700	-1.64076300	-3.95483000
C	-0.38032200	-3.31444500	-1.59036200
H	0.22761700	-3.54917700	-0.71048600
H	-1.08766800	-4.14278000	-1.73279900
H	0.28061500	-3.28286700	-2.46190800
C	-1.76893600	-2.45714600	1.09553200
H	-2.05289500	-1.87151900	1.97461800
H	-2.48896700	-3.27892400	0.98947000
H	-0.78642000	-2.89413000	1.30354600
C	-3.14899600	0.43982500	0.59953000
H	-2.93939800	1.50928000	0.49146400
H	-4.22212000	0.28730400	0.42599900
H	-2.93284300	0.17331200	1.63827400

C	-2.59261500	1.25962800	-2.38663400
H	-2.03867000	1.50368000	-3.29829900
H	-3.65537600	1.17273200	-2.65004800
H	-2.49359300	2.10259200	-1.69488600
C	3.52152500	1.61258400	-0.94387700
C	3.45629500	1.39920900	-2.31385500
C	2.23098000	0.76933900	-2.52001500
N	1.59255600	0.60959100	-1.35319600
H	4.28616800	2.07076400	-0.33150000
H	4.19777600	1.66609700	-3.05192300
H	1.76967400	0.42094200	-3.43572500
N	2.39407200	1.13037200	-0.39656900
C	0.62715600	0.45570400	1.04578900
C	1.89496900	1.06670800	0.93592000
C	0.08718500	0.37394700	2.33186300
C	2.59337500	1.56561200	2.02177700
C	0.75442000	0.86287400	3.44894200
H	-0.88420600	-0.07280800	2.53867100
C	2.00543100	1.45355100	3.28518400
H	3.57114600	2.03151600	1.90238800
H	2.49253900	1.81873800	4.18788000
C	0.08976000	0.74199400	4.84371300
O	-1.03759400	0.20513700	4.81546600
O	0.77570400	1.19622200	5.77484800



22

57

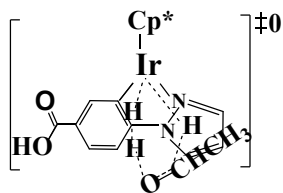
**E=-1294.886831(au)**

C	-0.80617800	-2.26118600	-1.23996400
C	-1.10932200	-1.33176600	-2.31398200
C	-2.10717500	-0.42911100	-1.87233800
C	-1.61844500	-1.90783800	-0.12512000
C	-2.38318200	-0.72888700	-0.47700000
Ir	-0.28345800	-0.14594100	-0.52681800
C	-0.49550900	-1.39221000	-3.67207300
H	-1.00572900	-2.13026700	-4.30539900
H	-0.54490500	-0.42403400	-4.18295100
H	0.55846100	-1.69191700	-3.61712200
C	0.13857800	-3.40981000	-1.34477400



H	0.40920700	-3.79551700	-0.35649700
H	-0.29460200	-4.24088000	-1.91876900
H	1.07001900	-3.11697100	-1.84565800
C	-1.69741000	-2.64126200	1.16948900
H	-2.01123700	-1.99102600	1.99252300
H	-2.42681400	-3.45868800	1.10289400
H	-0.73081200	-3.07259800	1.45195200
C	-3.47137700	-0.09843100	0.32623200
H	-3.56713500	0.96621200	0.08506100
H	-4.44202500	-0.57487500	0.12948100
H	-3.27857500	-0.17331000	1.40159900
C	-2.82017400	0.59908000	-2.68615300
H	-2.76135400	1.60223800	-2.24877100
H	-2.40462900	0.66465400	-3.69747900
H	-3.88135400	0.33303700	-2.78464700
C	3.75837600	0.75201600	-1.81308200
C	2.43777500	0.40928700	-2.13905500
H	4.57568200	0.94672000	-2.49195300
H	1.96789600	0.28848300	-3.10745100
N	2.54860200	0.48545100	0.00963400
C	0.60210300	0.07914200	1.29925000
C	1.98154100	0.36747900	1.29793700
C	0.02032500	-0.01645600	2.56449300
C	2.74955300	0.51618400	2.44709500
C	0.75442500	0.13721900	3.74171200
H	-1.04648900	-0.20487400	2.66711600
C	2.12838200	0.39590200	3.68182600
H	3.81940500	0.70663800	2.38880500
H	2.73394000	0.45366400	4.58514100
H	-0.37281500	1.45323700	-0.32910000
C	0.02235700	-0.02484300	5.02858500
O	-1.01489600	-0.62869600	5.13542500
O	0.58569500	0.55204500	6.11502400
C	1.01824900	3.67487900	-2.05542600
H	0.98322400	4.71129300	-1.70267100
H	1.28240800	3.03059000	-1.20459400
H	1.81564400	3.58678300	-2.80398300
C	-0.32338300	3.26362400	-2.62727100
H	-0.27197100	2.21616300	-2.98361400
H	-0.58004500	3.88447200	-3.49523400
O	-1.37243700	3.42600800	-1.70018500
H	-1.20655800	2.78468200	-0.99078400
C	3.79106000	0.79637200	-0.43602600
N	1.71627500	0.25014600	-1.03049200

H	4.59344700	1.02567400	0.25081000
H	1.31173100	1.12602100	5.84215100



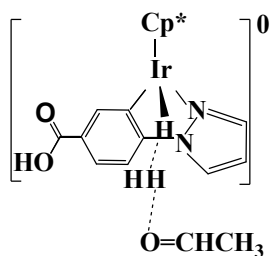
TS<sub>22-23</sub>

57 -646.34i cm<sup>-1</sup>

E=-1294.814606(au)

C	-1.19278100	-1.99052900	2.40091400
C	-1.68017400	-1.05370200	1.39941000
C	-2.65173800	-0.22562700	2.01551500
C	-1.92970600	-1.76369000	3.62340600
C	-2.78995100	-0.62854000	3.40866400
Ir	-0.70754200	-0.01610700	3.16347100
C	-1.23625200	-0.97863200	-0.02267100
H	-1.90134200	-1.55286300	-0.68124700
H	-1.22492800	0.05698300	-0.38210100
H	-0.22701800	-1.38732300	-0.15131100
C	-0.21043700	-3.08335500	2.15906900
H	0.27673700	-3.39134700	3.08968800
H	-0.70051900	-3.96570900	1.72630600
H	0.57666100	-2.76814900	1.46482700
C	-1.85037400	-2.58512000	4.86241800
H	-2.06594000	-1.99348600	5.75838700
H	-2.57806100	-3.40606300	4.82502400
H	-0.85473400	-3.02176900	4.99432400
C	-3.80650100	-0.08944000	4.35552900
H	-3.93052600	0.99026400	4.22784500
H	-4.78219500	-0.56779000	4.19458900
H	-3.52130300	-0.26742100	5.39799600
C	-3.38477900	0.90523400	1.38255400
H	-2.99920900	1.88508600	1.72047000
H	-3.30137600	0.86627200	0.29189500
H	-4.44942900	0.85749300	1.64118100
C	3.36593800	0.62955800	1.80803800
C	2.02928100	0.32877600	1.51246700
H	4.18256300	0.75587000	1.11253900
H	1.53933300	0.18373700	0.55671100
N	2.16904900	0.50725800	3.65539900
C	0.21256700	0.29395800	4.97399400
C	1.60154400	0.51153800	4.95036700
C	-0.37165900	0.29330100	6.24058200

C	2.37846400	0.70936700	6.08704400
C	0.37127300	0.49439200	7.40405300
H	-1.44654100	0.15533700	6.35202200
C	1.75362900	0.69929500	7.32532400
H	3.45463500	0.85376900	6.01697700
H	2.35970900	0.79975800	8.22441400
H	-1.68313900	1.86524600	3.99701600
C	-0.35681900	0.43272500	8.70222300
O	-1.38943700	-0.16770800	8.85821100
O	0.20955100	1.09512400	9.73607800
C	0.70916400	3.65626300	2.22427500
H	0.70194000	4.67745500	1.82584600
H	0.79124000	3.72826100	3.31744500
H	1.59411200	3.13433700	1.83166200
C	-0.58660000	2.93427600	1.86822000
H	-0.43268900	1.85382000	2.33054600
H	-0.63058700	2.68332400	0.77714200
O	-1.68732300	3.45681900	2.36427600
H	-1.84422500	2.56744200	3.56660000
C	3.41654500	0.74070800	3.18217700
N	1.31742300	0.25547000	2.63646400
H	4.23643200	0.97066800	3.84782700
H	0.92567700	1.65598000	9.41353500



23

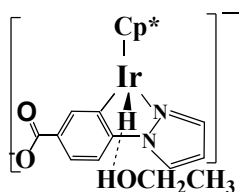
57

**E=-1294.849726(au)**

C	-0.83983300	-2.21496500	-1.51932400
C	-1.31531600	-1.12496200	-2.35839000
C	-2.25006500	-0.36461900	-1.60503500
C	-1.47481900	-2.11540100	-0.25690600
C	-2.31156700	-0.92631100	-0.27067600
Ir	-0.28060200	-0.18552200	-0.55188600
C	-0.96927900	-0.94173400	-3.79785600
H	-1.58334400	-1.58672200	-4.44187500
H	-1.13044700	0.09255500	-4.12141200
H	0.07869500	-1.19962400	-3.99788400
C	0.13273100	-3.25114400	-1.96987500

H	0.52984500	-3.82541500	-1.12696100
H	-0.33206300	-3.95978000	-2.66894400
H	0.98686000	-2.79740800	-2.48957300
C	-1.31994400	-3.02962000	0.90926000
H	-1.24762500	-2.47042900	1.84991000
H	-2.17893900	-3.70791800	0.99593100
H	-0.41563500	-3.64098000	0.82519600
C	-3.27747100	-0.52717500	0.79482900
H	-3.36869900	0.56277300	0.86447800
H	-4.27878800	-0.93526100	0.60024500
H	-2.96475300	-0.89400700	1.77885800
C	-3.04681000	0.80086500	-2.08323800
H	-3.28315700	1.48059900	-1.25764500
H	-2.50747900	1.39621800	-2.82744600
H	-3.99492100	0.46586000	-2.52512700
C	3.78830000	0.63908800	-1.79951200
C	2.47085900	0.29211700	-2.13534400
H	4.62048300	0.79607200	-2.47017600
H	2.01969800	0.12525100	-3.10613300
N	2.54392800	0.45329600	0.01083200
C	0.57160100	0.10792300	1.27814300
C	1.95175200	0.39498300	1.29334300
C	-0.03567000	0.06160900	2.53623400
C	2.69764600	0.59294500	2.44933900
C	0.67651800	0.26689100	3.71953200
H	-1.10542500	-0.12472000	2.62288100
C	2.05133100	0.52533900	3.67543000
H	3.76880100	0.78052000	2.40561400
H	2.63802900	0.62226200	4.58772200
H	-1.57803200	2.82480100	0.87395000
C	-0.07574200	0.16251100	5.00118100
O	-1.10635200	-0.44887800	5.12430500
O	0.46280800	0.80508700	6.06350600
C	1.00866600	3.69250900	-1.39297800
H	1.91330200	3.92057800	-1.97071900
H	0.62482700	4.59643700	-0.91291800
H	1.29227600	2.95720300	-0.62768400
C	-0.03378300	3.08998300	-2.28368000
H	-0.39979500	1.40302600	-0.43782600
H	0.30459200	2.18900900	-2.85242600
O	-1.15688700	3.51612000	-2.41795900
H	-1.70433600	3.48199600	0.54227500
C	3.79708500	0.73713900	-0.42465500
N	1.72687400	0.18368700	-1.03398600

H	4.58965800	0.98525300	0.26700700
H	1.18590200	1.37268900	5.77019700



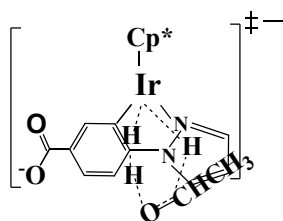
24

56

E=-1294.429746(au)

C	-0.79318400	-2.24537100	-1.18457200
C	-1.16177500	-1.34689700	-2.26603500
C	-2.14915300	-0.45071900	-1.79276600
C	-1.56050100	-1.88951100	-0.04139800
C	-2.35285400	-0.72446300	-0.37847900
Ir	-0.26753700	-0.10106200	-0.53556300
C	-0.61255700	-1.43561500	-3.65066300
H	-1.11515600	-2.21931800	-4.23593700
H	-0.72477000	-0.48893300	-4.19196500
H	0.45659600	-1.68327800	-3.63474900
C	0.18526100	-3.36418800	-1.30667500
H	0.48649900	-3.73542200	-0.32151800
H	-0.22676000	-4.21316300	-1.87236900
H	1.09855200	-3.03840500	-1.82232800
C	-1.57238800	-2.60066300	1.26852300
H	-1.76998400	-1.93099000	2.11262600
H	-2.34694700	-3.37974400	1.27201900
H	-0.60883600	-3.07935300	1.47398400
C	-3.40206000	-0.09545200	0.47616500
H	-3.52673300	0.96418300	0.22384600
H	-4.37771300	-0.58826500	0.35073800
H	-3.13615300	-0.14652900	1.53771000
C	-2.91021500	0.55740400	-2.58918600
H	-2.83343300	1.56877600	-2.17389600
H	-2.54366500	0.60686300	-3.62109600
H	-3.97543800	0.28834900	-2.63104100
C	3.79443300	0.69642700	-1.81267100
C	2.47091100	0.38807500	-2.14343400
H	4.62151600	0.86969000	-2.48628600
H	1.99696900	0.28357900	-3.11213500
N	2.57077000	0.46457500	0.00995600
C	0.60836300	0.14401600	1.29606600
C	1.99381500	0.36438100	1.30302300
C	-0.00066500	0.06302400	2.54716200

C	2.75332300	0.46047000	2.46933800
C	0.72185700	0.11674700	3.73653400
H	-1.07751200	-0.05708600	2.65746800
C	2.10375600	0.32586100	3.68778600
H	3.83132200	0.62342600	2.42189100
H	2.62895800	0.37323200	4.63965300
H	-0.32816200	1.49784700	-0.34508600
C	-0.00350000	-0.09320600	5.08862100
O	-1.21409300	-0.39144900	4.98866100
O	0.71868800	0.04690800	6.09724200
C	1.01687300	3.62359800	-2.19433000
H	0.99250800	4.67497300	-1.88593800
H	1.30053000	3.01522300	-1.32444700
H	1.79507800	3.49861200	-2.95850900
C	-0.34079400	3.19226700	-2.71293600
H	-0.30174500	2.12870900	-3.01744300
H	-0.61659400	3.77479100	-3.60322300
O	-1.36409800	3.39966300	-1.76771800
H	-1.19522200	2.76016800	-1.05390600
C	3.81809600	0.74162500	-0.42884200
N	1.73973300	0.25084300	-1.03159000
H	4.61685400	0.94933700	0.26922900



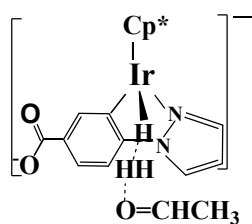
TS<sub>24-25</sub>

56 -493.35i cm<sup>-1</sup>

E=-1294.360037(au)

C	-1.15869300	-1.93234200	2.52258600
C	-1.68931200	-1.09068200	1.45913100
C	-2.65717700	-0.23406100	2.03361300
C	-1.89815100	-1.64992700	3.73722300
C	-2.77646300	-0.54615900	3.45458000
Ir	-0.70355200	0.07291900	3.16387900
C	-1.26516000	-1.10154300	0.02849600
H	-1.96372200	-1.67504800	-0.59735300
H	-1.21103400	-0.08562000	-0.38103600
H	-0.27661700	-1.55986800	-0.09216200
C	-0.14729300	-3.01325400	2.35217000
H	0.37008600	-3.21346400	3.29611300
H	-0.61333900	-3.94913000	2.01351600

H	0.61537100	-2.73329600	1.61609900
C	-1.80687600	-2.40732100	5.01671300
H	-2.00395300	-1.78198400	5.89487100
H	-2.53314900	-3.23164000	5.01815300
H	-0.80874600	-2.83600300	5.15618400
C	-3.78257300	0.04515500	4.38173300
H	-3.91500700	1.11394700	4.18582300
H	-4.75843900	-0.44843500	4.26923400
H	-3.47364400	-0.05902100	5.42742000
C	-3.40495800	0.84747400	1.33423700
H	-2.97733800	1.84812000	1.54768600
H	-3.38499600	0.69499400	0.24931700
H	-4.45387000	0.85690400	1.65543600
C	3.37899300	0.74017000	1.83639600
C	2.05286500	0.42709300	1.52702900
H	4.20302700	0.87764500	1.15124900
H	1.57070600	0.28647200	0.56709300
N	2.16451700	0.60786200	3.67471400
C	0.19713600	0.40573600	4.97566600
C	1.58643500	0.58740800	4.97160200
C	-0.40941300	0.34674200	6.22802200
C	2.35053500	0.69674900	6.13342500
C	0.31827300	0.39548600	7.41295500
H	-1.48604800	0.23315700	6.34520200
C	1.70152700	0.59234900	7.35592600
H	3.43130500	0.83560400	6.08021400
H	2.23280900	0.64022900	8.30439700
H	-1.65898500	2.02546200	3.86347000
C	-0.40267800	0.15157100	8.76156500
O	-1.59903700	-0.19777300	8.65055800
O	0.31065900	0.30829200	9.77262300
C	0.65342900	3.72719300	1.98726800
H	0.62284600	4.73637300	1.55752600
H	0.69461400	3.82831400	3.08062400
H	1.57109200	3.22409900	1.64672400
C	-0.60376400	2.94318600	1.61314000
H	-0.43575000	1.90770800	2.13535300
H	-0.57957700	2.64154700	0.53042300
O	-1.74323000	3.47322700	2.01545800
H	-1.86297900	2.64717600	3.35605500
C	3.40952300	0.85255100	3.21747800
N	1.32884500	0.34674900	2.64899700
H	4.21243000	1.09249400	3.90032800



25

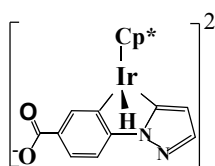
56

**E=-1294.392848(au)**

C	-0.86247400	-2.26936700	-1.40068500
C	-1.34190500	-1.23043800	-2.29977200
C	-2.25746900	-0.41715100	-1.57905500
C	-1.48550500	-2.09330300	-0.14025400
C	-2.31373800	-0.90293300	-0.21420400
Ir	-0.28199900	-0.18091100	-0.55376500
C	-1.00479200	-1.12574700	-3.74961600
H	-1.65686500	-1.75918700	-4.36976800
H	-1.10811200	-0.09543600	-4.11055300
H	0.02688600	-1.44551700	-3.94509800
C	0.11567400	-3.32582700	-1.79028800
H	0.52127100	-3.83741800	-0.91124000
H	-0.33959700	-4.08523400	-2.44263400
H	0.96599500	-2.89483100	-2.33628900
C	-1.32459600	-2.92867900	1.08333300
H	-1.10784300	-2.31124600	1.96477000
H	-2.24038500	-3.49702500	1.29630500
H	-0.50198900	-3.64381000	0.97666700
C	-3.26079600	-0.43561900	0.84080800
H	-3.34434900	0.65728200	0.84461100
H	-4.26783800	-0.85175700	0.69056500
H	-2.92560500	-0.73157800	1.84063800
C	-3.04601000	0.73035800	-2.11356200
H	-3.24375700	1.46730100	-1.32739100
H	-2.51227600	1.26210800	-2.90919600
H	-4.01456000	0.39364900	-2.51039800
C	3.78440900	0.59455400	-1.82136800
C	2.46978800	0.24531100	-2.14875400
H	4.62004400	0.73057100	-2.49312400
H	2.01413600	0.05365700	-3.11301600
N	2.53914500	0.45922600	-0.00256800
C	0.56656800	0.16636100	1.27815700
C	1.94436300	0.43744900	1.28692500
C	-0.05184400	0.14652100	2.53098500
C	2.68537400	0.65463700	2.44920100



C	0.65142800	0.33967900	3.71889000
H	-1.12330400	-0.01891800	2.64299200
C	2.02490200	0.59883700	3.66703600
H	3.75709900	0.85503100	2.40103500
H	2.53205200	0.74996800	4.61785000
H	-1.55122800	2.92197400	0.87056400
C	-0.08096100	0.25439700	5.08234400
O	-1.29701600	-0.02344700	5.00680800
O	0.64425800	0.46702600	6.07659200
C	1.08056300	3.58701000	-1.40902400
H	2.05293700	3.66425700	-1.91229000
H	0.74960900	4.56790300	-1.05744100
H	1.21738500	2.91226200	-0.55309400
C	0.06721000	2.99287400	-2.33845000
H	-0.39762900	1.40435000	-0.46047100
H	0.37342400	2.02306700	-2.79813100
O	-0.99996400	3.49722000	-2.60892800
H	-1.74641700	3.43428900	0.36328600
C	3.78899600	0.72649500	-0.44284400
N	1.72427000	0.16777000	-1.03869800
H	4.57628200	0.98809500	0.25001400



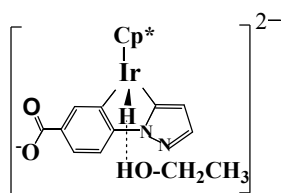
**F<sub>Ir</sub>**

**46**

**E=-1138.951017(au)**

C	-1.25322000	-2.00804100	2.30618000
C	-1.84729300	-1.09926900	1.34987700
C	-2.85158000	-0.35188600	2.03622300
C	-1.89581400	-1.81325700	3.56143600
C	-2.89092000	-0.78035700	3.40715700
Ir	-0.83553900	0.17959400	2.99795500
C	-1.52121000	-1.05784200	-0.10553700
H	-2.04707100	-1.83994200	-0.68150400
H	-1.78483900	-0.08872600	-0.54747200
H	-0.44533200	-1.20220500	-0.26911500
C	-0.15806000	-2.96943000	1.98377800
H	0.27543500	-3.39413200	2.89661500
H	-0.50801000	-3.80647100	1.35720100
H	0.65965000	-2.46831900	1.44733500
C	-1.61356000	-2.52200000	4.84350300

H	-1.46706600	-1.80604600	5.66397500
H	-2.43585700	-3.19676200	5.12629700
H	-0.69541500	-3.11671500	4.77564500
C	-3.88341000	-0.36467000	4.44139000
H	-4.15502500	0.69261800	4.33342400
H	-4.81538300	-0.95446700	4.39254900
H	-3.47557100	-0.47948900	5.45243100
C	-3.77061900	0.65605200	1.42811400
H	-3.31270300	1.13575700	0.55454800
H	-4.72362900	0.20563600	1.10521800
H	-4.00408700	1.45104700	2.14596400
C	3.18794500	0.79481400	1.74103200
C	1.88500300	0.49311700	1.28884900
H	4.10415600	0.87466400	1.15800300
H	1.55665600	0.30997600	0.27055100
N	1.95253800	0.82660200	3.43960900
C	0.05734600	0.63116600	4.79635100
C	1.44162200	0.88875200	4.75036600
C	-0.53140000	0.65960000	6.06414000
C	2.20165700	1.15270000	5.88278300
C	0.20067500	0.90349900	7.23584300
H	-1.60287600	0.49861100	6.19518800
C	1.56913400	1.15429700	7.12592500
H	3.26987800	1.34185600	5.77208000
H	2.11213700	1.34850200	8.04995200
H	-0.92480300	1.77324600	2.93012300
C	-0.48462500	0.89229400	8.62052500
O	-1.71056100	0.62659900	8.62360300
O	0.26250400	1.14604200	9.59664900
C	1.07726100	0.51926100	2.43015300
N	3.24133100	0.99950300	3.05683800



26

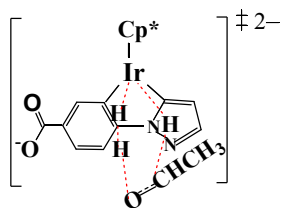
55

E=-1293.956325(au)

C	-0.78725700	-2.12609700	-1.44781800
C	-1.36858400	-1.09445100	-2.28139300
C	-2.37643500	-0.43854100	-1.50951700
C	-1.43985700	-2.09268600	-0.18019900
C	-2.42638600	-1.04162100	-0.20501100

Ir	-0.36176300	-0.06649100	-0.48224100
C	-1.02191100	-0.82246000	-3.70971400
H	-1.70838300	-1.31990900	-4.41587400
H	-1.03612100	0.25510300	-3.92006600
H	-0.00853300	-1.18055200	-3.93400900
C	0.30653600	-3.04801300	-1.87288000
H	0.73362400	-3.57117300	-1.00986900
H	-0.04414100	-3.80876400	-2.58862200
H	1.12931800	-2.49326600	-2.34441400
C	-1.16616000	-2.96965600	0.99564900
H	-1.08099100	-2.37954600	1.91784500
H	-1.96149900	-3.71593900	1.14342800
H	-0.21718000	-3.50538600	0.87749700
C	-3.41586900	-0.74651800	0.87207700
H	-3.68262100	0.31733900	0.88469600
H	-4.34922000	-1.32307600	0.75478400
H	-3.00642500	-0.98008600	1.86188300
C	-3.29270300	0.63541700	-1.99817400
H	-3.54630700	1.32947700	-1.18796100
H	-2.82702600	1.22574900	-2.79509900
H	-4.23534200	0.21574800	-2.38497600
C	3.68344600	0.54208500	-1.67980100
C	2.38018100	0.27517400	-2.15402500
H	4.60364600	0.64193300	-2.25222300
H	2.06006400	0.13074900	-3.18169500
N	2.43551800	0.50791100	0.01176200
C	0.54806700	0.17097700	1.35539100
C	1.92957300	0.44174500	1.32591700
C	-0.03447400	0.06468900	2.62036700
C	2.69702700	0.58850100	2.47462700
C	0.70631200	0.18379300	3.80535000
H	-1.10481300	-0.11217800	2.74060100
C	2.07284700	0.45295700	3.71392800
H	3.76383100	0.79175200	2.37833200
H	2.62053500	0.54724500	4.65054000
H	-0.45078700	1.52143900	-0.26740500
C	0.03116700	0.01350900	5.18495000
O	-1.18940900	-0.27315700	5.16349300
O	0.78140000	0.17487900	6.17742500
C	1.56340700	0.26546000	-1.01769700
N	3.72870500	0.68115300	-0.35551900
C	1.31709100	3.66651600	-2.09483200
H	0.73920400	4.48847000	-1.65422300
H	1.50750700	2.91849300	-1.31448000

H	2.28827000	4.05353800	-2.43107400
C	0.55624600	3.03377000	-3.24280700
H	1.17739700	2.23068700	-3.67956800
H	0.37821600	3.77399100	-4.04008800
O	-0.70546500	2.54757900	-2.85959100
H	-0.56364300	1.91791400	-2.11773000



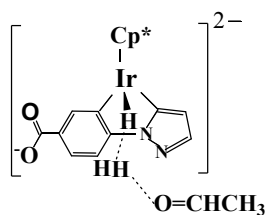
TS<sub>26-27</sub>

55 -334.31i cm<sup>-1</sup>

E=-1293.886978(au)

C	-1.06967600	-1.79611100	2.51825800
C	-1.65566500	-0.96414200	1.48489000
C	-2.67778800	-0.19056000	2.10265200
C	-1.83236600	-1.59037800	3.74859200
C	-2.81715000	-0.58542800	3.48733600
Ir	-0.67313300	0.17619700	3.21930400
C	-1.23252400	-0.88239300	0.05671700
H	-1.84422400	-1.51952300	-0.60298500
H	-1.30369400	0.14915700	-0.31193100
H	-0.18676000	-1.19177300	-0.06083400
C	-0.01390100	-2.82986400	2.31472700
H	0.52225700	-3.02343300	3.25066300
H	-0.43810900	-3.78070800	1.95698500
H	0.73260300	-2.48742600	1.58910500
C	-1.66975800	-2.37324000	5.00727200
H	-1.92437700	-1.78779700	5.89837500
H	-2.30236900	-3.27322900	4.98881300
H	-0.62903600	-2.68882600	5.14017100
C	-3.83849100	-0.05701700	4.43759100
H	-3.96305200	1.02537300	4.31416700
H	-4.82428700	-0.52699400	4.29006000
H	-3.54047500	-0.22900500	5.47819700
C	-3.48555800	0.87009300	1.43539400
H	-3.05693400	1.88446500	1.59929200
H	-3.52955600	0.69834600	0.35240900
H	-4.51419300	0.86959000	1.81913800
C	3.43853600	0.47224200	2.10246800
C	2.12394200	0.36463300	1.60008800
H	4.37233700	0.51902000	1.54675600

H	1.79840300	0.34902300	0.56470600
N	2.17086500	0.44798100	3.77681000
C	0.22316700	0.40556700	5.06496000
C	1.62719600	0.45571000	5.07775300
C	-0.41338700	0.36598900	6.30392200
C	2.36958900	0.47479300	6.25169900
C	0.29605500	0.32523500	7.50971700
H	-1.50028000	0.33437100	6.38834900
C	1.68874200	0.40223400	7.46749200
H	3.45676300	0.52087000	6.19323200
H	2.21354700	0.38441200	8.42173200
H	-1.62213500	2.20561700	3.89469900
C	-0.45196800	0.11606000	8.84371300
O	-1.67336000	-0.15108000	8.73586100
O	0.24746600	0.20945800	9.87899600
C	1.30030400	0.35466400	2.72542800
N	3.47557900	0.51891200	3.43512200
C	0.45758600	3.83097700	1.42290800
H	0.31278000	4.74602100	0.83005800
H	0.64172300	4.12793100	2.46399700
H	1.34589300	3.29661300	1.05606000
C	-0.79334400	2.95108300	1.37364500
H	-0.49273700	2.01871100	2.00254200
H	-0.88371100	2.49692500	0.34079900
O	-1.90090300	3.51698800	1.82786200
H	-1.85812900	2.76117700	3.35351800



27

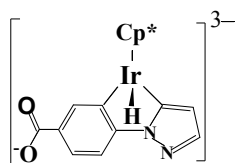
55

**E=-1293.915456(au)**

C	-0.80692600	-2.11218300	-1.42330500
C	-1.31399600	-1.05508900	-2.27255500
C	-2.30349200	-0.34223200	-1.53436900
C	-1.49317300	-2.04158800	-0.17534000
C	-2.41745200	-0.93680700	-0.22726200
Ir	-0.30013600	-0.07559900	-0.43467400
C	-0.92932900	-0.84227600	-3.69881900
H	-1.47413100	-1.51297600	-4.38456700
H	-1.12923600	0.18767500	-4.02177200

H	0.14262300	-1.02890300	-3.84760700
C	0.24041000	-3.09161600	-1.83544300
H	0.65068100	-3.61887300	-0.96664500
H	-0.14553100	-3.84784300	-2.53886900
H	1.08102400	-2.57922500	-2.32286900
C	-1.31017000	-2.93867300	1.00272700
H	-1.14811600	-2.36171400	1.92334100
H	-2.18664200	-3.58528000	1.15895600
H	-0.43384300	-3.58433300	0.87586600
C	-3.40781700	-0.57603900	0.82975100
H	-3.58598700	0.50662300	0.85420600
H	-4.38272400	-1.07181200	0.68432100
H	-3.04075400	-0.85460200	1.82448000
C	-3.14177900	0.78186400	-2.04907900
H	-3.45004800	1.44530000	-1.23243500
H	-2.60155100	1.40126100	-2.77638100
H	-4.05827500	0.41304100	-2.53678300
C	3.73826200	0.67468900	-1.58781800
C	2.44448300	0.39456800	-2.08106200
H	4.65640300	0.83520200	-2.14999300
H	2.13381800	0.31162600	-3.11870200
N	2.49001000	0.49539800	0.09365200
C	0.59978000	0.08237700	1.41245800
C	1.97890100	0.36978700	1.40146500
C	0.01283900	-0.07425100	2.67062000
C	2.73871100	0.48399600	2.55887600
C	0.74574000	0.01202500	3.86290900
H	-1.05568900	-0.26862600	2.78091000
C	2.10970400	0.29860500	3.78921800
H	3.80335700	0.70367600	2.47616800
H	2.65022800	0.36659300	4.73223400
H	-1.85095400	3.27040000	-0.28067600
C	0.06447000	-0.21065000	5.23183300
O	-1.15240300	-0.51093900	5.19278600
O	0.80653300	-0.07195100	6.23379500
C	1.62634400	0.28512300	-0.94964000
N	3.77645300	0.73648000	-0.25714800
C	1.03587500	3.56361700	-1.93103400
H	2.03247100	3.19451100	-2.20754700
H	0.95996700	4.64873900	-2.05298300
H	0.91049600	3.26882300	-0.88030800
C	0.00365100	2.85766400	-2.74862200
H	-0.35311000	1.50490500	-0.18684600
H	0.00276400	1.75279000	-2.61602600

O	-0.79440600	3.41288700	-3.48129500
H	-2.05378000	3.78835500	-0.78021100



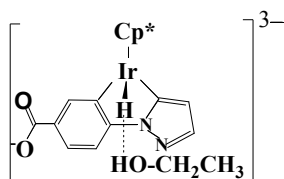
**3-F<sub>Ir</sub>**

**46**

**E=-1138.867833(au)**

C	-1.16061600	-1.78633100	2.61554300
C	-1.81989600	-1.02283900	1.59351500
C	-2.90061200	-0.31758700	2.23989500
C	-1.88215500	-1.63906800	3.83590200
C	-2.92183400	-0.71220600	3.61136600
Ir	-0.70347800	0.70336400	2.50482400
C	-1.63889100	-1.20715400	0.11984000
H	-2.16175900	-2.10699000	-0.24999900
H	-2.01762100	-0.34097600	-0.43538300
H	-0.57621300	-1.30410400	-0.13808200
C	0.05672700	-2.63211800	2.44175700
H	0.80147800	-2.40705700	3.21872900
H	-0.16486900	-3.71031200	2.50444400
H	0.53926400	-2.44074100	1.47542500
C	-1.46583300	-2.23896800	5.13616200
H	-1.87861500	-1.70976400	6.00621500
H	-1.75123600	-3.30194300	5.20666600
H	-0.37249400	-2.19267100	5.24765900
C	-3.88497400	-0.19209500	4.62659900
H	-4.01934600	0.89315700	4.51301700
H	-4.88320600	-0.64857000	4.51900800
H	-3.54045300	-0.36340100	5.65479200
C	-3.97417200	0.46633900	1.55836300
H	-3.60193000	0.93257900	0.63790300
H	-4.84946200	-0.15355500	1.29347300
H	-4.33843200	1.27718200	2.20325600
C	3.45199900	0.99759900	1.72180000
C	2.16971700	1.03763300	1.13432200
H	4.42247400	1.05202500	1.23234300
H	1.90850600	1.13606000	0.08712200
N	2.07800700	0.85798500	3.30548300
C	0.05835700	0.76419100	4.48287500
C	1.46203800	0.75568300	4.56906300
C	-0.63903100	0.71255700	5.68738700

C	2.14237300	0.65854900	5.77645100
C	0.00040100	0.55835000	6.92448800
H	-1.72626900	0.72427700	5.70616300
C	1.39515100	0.54995800	6.95231500
H	3.23238700	0.65576100	5.77867600
H	1.87210600	0.44223000	7.92613600
H	-0.90626700	1.57912900	1.08156400
C	-0.82843800	0.29723100	8.19530800
O	-2.03902300	0.00957900	8.00119900
O	-0.20848300	0.36894900	9.28099100
C	1.26893800	0.94344400	2.19690200
N	3.40513300	0.89041700	3.05027500



3-1

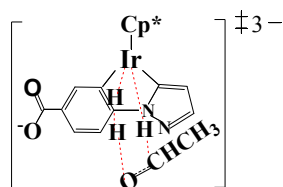
55

E=-1293.880615(au)

C	-0.72914300	-2.28375000	-1.87129400
C	-1.40324000	-1.22582500	-2.52919400
C	-2.37053400	-0.67460200	-1.63604200
C	-1.15441000	-2.27630100	-0.50663400
C	-2.23397700	-1.34715600	-0.36966100
Ir	-0.42950600	0.09220100	-0.44149400
C	-1.19832500	-0.80050900	-3.94634800
H	-1.81058100	-1.38041300	-4.65679400
H	-1.45741800	0.25680100	-4.08242700
H	-0.14926100	-0.91710900	-4.24982900
C	0.39816500	-3.09934100	-2.39729600
H	0.28935100	-4.16062200	-2.12842600
H	0.46330700	-3.04050000	-3.49189600
H	1.36317700	-2.75194300	-1.99328300
C	-0.61255300	-3.16863500	0.56038700
H	-0.86111600	-2.78989700	1.55805200
H	-0.99503600	-4.19955400	0.48278100
H	0.48351400	-3.21485500	0.50551100
C	-3.14604400	-1.23648300	0.80705900
H	-3.63313400	-0.25542200	0.84200300
H	-3.93295300	-2.00832300	0.79117600
H	-2.59454500	-1.33738400	1.74906700
C	-3.43322400	0.30638100	-2.00795100
H	-3.03713100	1.10120900	-2.65329400



H	-4.27284900	-0.17280900	-2.53822200
H	-3.83802300	0.80079300	-1.11700800
C	3.74888300	-0.23618900	-1.52641800
C	2.44342500	-0.34695300	-2.04663700
H	4.69899700	-0.30441800	-2.05206900
H	2.14930200	-0.52204800	-3.07735800
N	2.43915500	-0.01944200	0.10308500
C	0.48897500	0.37972100	1.36877400
C	1.89146700	0.23918400	1.37842600
C	-0.12814600	0.57772600	2.60839000
C	2.64756300	0.31365200	2.54158900
C	0.60016400	0.63719000	3.80497500
H	-1.20857500	0.69857100	2.68510700
C	1.98953600	0.51627600	3.75202000
H	3.72977400	0.20265400	2.47652600
H	2.52266000	0.58053900	4.69941200
H	-1.50770400	1.24088500	0.15198600
C	-0.10806400	0.82799200	5.16704500
O	-1.35896600	0.87040400	5.13041400
O	0.65491300	0.91127100	6.15976000
C	1.58362800	-0.20792300	-0.95076300
N	3.75264700	-0.02979400	-0.20787400
C	1.25902700	3.28451100	-1.68558400
H	1.11604700	4.34827000	-1.45624400
H	1.18066400	2.71369800	-0.74989700
H	2.27393400	3.13025300	-2.07478000
C	0.21908500	2.80232400	-2.67737200
H	0.41698800	1.74091300	-2.91270900
H	0.29323500	3.36933500	-3.61891700
O	-1.10210200	2.97451900	-2.21437900
H	-1.20897000	2.37183400	-1.44996300



3-TS<sub>1-2</sub>

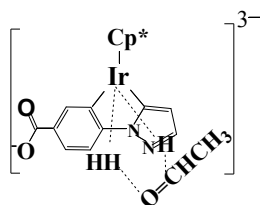
55 -396.11i cm<sup>-1</sup>

E=-1293.842444(au)

C	-1.15472200	-1.91475100	2.53109500
C	-1.57365300	-0.85421100	1.64153800
C	-2.61304400	-0.10715000	2.29687800
C	-1.83621600	-1.75674700	3.74769200

C	-2.69913200	-0.60302300	3.63361500
Ir	-0.59462300	0.48544800	3.27197500
C	-1.17884000	-0.74475800	0.20478400
H	-1.70867800	-1.47578200	-0.42891600
H	-1.39081500	0.25755100	-0.18581500
H	-0.10169300	-0.91999200	0.08003300
C	-0.07213300	-2.88697700	2.20716600
H	0.15654900	-3.53451300	3.06096900
H	-0.33919000	-3.53472500	1.35797000
H	0.85682600	-2.36275600	1.93807000
C	-1.68364800	-2.56032700	4.99267300
H	-1.44105600	-1.92977000	5.86156900
H	-2.61336900	-3.09373900	5.23915900
H	-0.88627600	-3.30610600	4.89746400
C	-3.68616400	-0.15820900	4.66414300
H	-3.79948800	0.93280100	4.65465000
H	-4.68210500	-0.59908300	4.49313500
H	-3.37176700	-0.44161200	5.67647100
C	-3.52486400	0.89969300	1.66732800
H	-3.09628700	1.91805000	1.61330400
H	-3.78725800	0.58913000	0.64555000
H	-4.46010800	0.96514700	2.23848800
C	3.53477300	0.55460900	2.28112400
C	2.23032300	0.58136400	1.74304500
H	4.48257400	0.55703800	1.74791100
H	1.93413600	0.62888100	0.70051100
N	2.23063000	0.56266200	3.92429000
C	0.24096300	0.49337500	5.13172500
C	1.65079600	0.48533500	5.19495700
C	-0.44984800	0.36603400	6.33849800
C	2.34311800	0.38881600	6.39506200
C	0.21054600	0.21622300	7.56019200
H	-1.53821000	0.35558000	6.37442200
C	1.60759400	0.25028200	7.57225400
H	3.43230600	0.39470400	6.38544800
H	2.09017100	0.14032000	8.54269000
H	-1.42483300	2.49936300	3.61055500
C	-0.59420700	-0.06930200	8.84640300
O	-1.81686800	-0.28425600	8.67059600
O	0.07116700	-0.08139300	9.90736400
C	1.37691200	0.59539500	2.84677200
N	3.54512800	0.53463700	3.61470500
C	0.40110000	3.81874700	0.90842500
H	0.23308000	4.78625000	0.41351200

H	0.73903500	4.01570400	1.93423500
H	1.20383200	3.27822000	0.38443200
C	-0.89981700	3.01583500	0.96066300
H	-0.60564400	2.03283400	1.47863100
H	-1.16244000	2.68356000	-0.08314900
O	-1.90494000	3.63257300	1.59615500
H	-1.67732000	3.02053000	2.98683400



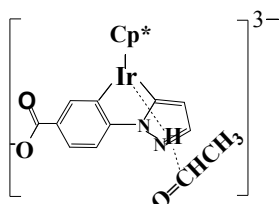
3-2

55

E=-1293.852296(au)

C	-1.30897300	-1.96748100	2.02218300
C	-1.84898000	-0.79357600	1.41178900
C	-2.73371100	-0.17258400	2.34991500
C	-1.86166700	-2.06760700	3.34456300
C	-2.71170900	-0.93356100	3.55879300
Ir	-0.47987600	-0.19109600	3.28573700
C	-1.61511300	-0.31614900	0.01584900
H	-2.34174500	-0.75082000	-0.69043200
H	-1.69918800	0.77896400	-0.04149800
H	-0.61215300	-0.59153500	-0.33696700
C	-0.36993800	-2.93168900	1.37786800
H	0.23838100	-3.45366700	2.12679500
H	-0.89327300	-3.69355600	0.77846700
H	0.32939200	-2.40716800	0.71457800
C	-1.57575200	-3.13136200	4.35162400
H	-1.46375600	-2.70224700	5.35528900
H	-2.37855500	-3.88410900	4.39822400
H	-0.64096400	-3.65649600	4.12040600
C	-3.53089900	-0.66322300	4.77708900
H	-3.62446500	0.41453000	4.95842900
H	-4.54760600	-1.07888100	4.69471700
H	-3.07097900	-1.08602600	5.67786000
C	-3.57718000	1.02101900	2.06274000
H	-2.99134800	1.82431000	1.59023000
H	-4.39707900	0.75598300	1.37481600
H	-4.03029100	1.41809300	2.97779100
C	3.63083200	0.30479700	2.30047400
C	2.37873900	-0.10570900	1.78806100
H	4.59009100	0.34248700	1.78939900

H	2.14345900	-0.43412400	0.78071000
N	2.25300100	0.51519200	3.86989800
C	0.22650300	0.48857700	5.05708900
C	1.62177000	0.75135000	5.10316400
C	-0.47049000	0.64395900	6.26894800
C	2.27720900	1.15481300	6.25344800
C	0.15894300	1.03169400	7.45606000
H	-1.54410700	0.46160000	6.33412100
C	1.53031700	1.29453700	7.42627800
H	3.35034300	1.33986900	6.22123800
H	1.98618900	1.60313800	8.36623600
H	-2.22529700	3.16020500	3.94911800
C	-0.62903600	1.14867600	8.78038400
O	-1.83928800	0.83303300	8.71884000
O	0.03832900	1.53907700	9.76733700
C	1.47811300	0.04680200	2.84075300
N	3.56289100	0.68441800	3.57556500
C	0.65755100	3.35310300	2.11675100
H	0.95676100	4.21442100	1.50217600
H	0.13932600	3.73149000	3.00573100
H	1.55991700	2.81971300	2.44356000
C	-0.26016500	2.43587700	1.30835500
H	-0.48322000	1.52619700	2.06399600
H	0.35114100	1.87281000	0.54946400
O	-1.37991400	2.95045300	0.86067400
H	-2.12017900	3.26899200	3.21456700



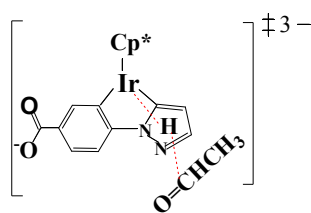
3-3

53

E=-1292.679118(au)

C	-1.01185100	-2.06612100	-1.54986700
C	-1.47902400	-0.95484300	-2.32404200
C	-2.35560300	-0.18289900	-1.49516300
C	-1.59957300	-1.97771700	-0.24377800
C	-2.40886400	-0.79607000	-0.20280600
Ir	-0.15385100	-0.16521600	-0.50471200
C	-1.16951300	-0.68071300	-3.75937500
H	-1.91647700	-1.13627900	-4.43008000
H	-1.14289500	0.40109900	-3.96528300

H	-0.19064400	-1.09650000	-4.03370800
C	-0.10831400	-3.14850600	-2.03682300
H	0.43048900	-3.61826900	-1.20518800
H	-0.65705200	-3.94134300	-2.56982500
H	0.65001400	-2.75079900	-2.72225400
C	-1.38438100	-2.93257700	0.88284500
H	-1.41113100	-2.41938700	1.85090700
H	-2.14578100	-3.72757000	0.90244800
H	-0.40060500	-3.41200300	0.81022200
C	-3.27085800	-0.35236800	0.93252100
H	-3.24423600	0.73751500	1.05097500
H	-4.32234100	-0.64443300	0.78359900
H	-2.94120000	-0.77750500	1.88698500
C	-3.11385600	1.03002700	-1.91548700
H	-4.03453700	0.75203500	-2.45484300
H	-3.41534300	1.62207800	-1.04239900
H	-2.51763300	1.67748200	-2.57862000
C	3.96228200	0.25404100	-1.51723800
C	2.67900000	-0.00772500	-2.04863600
H	4.91328000	0.30000800	-2.04300100
H	2.40632300	-0.18717500	-3.08338400
N	2.62622200	0.35140500	0.09722800
C	0.62943900	0.25014600	1.31817700
C	2.03375800	0.44875900	1.36486400
C	-0.04080100	0.28885900	2.55319200
C	2.72412300	0.68857900	2.54127600
C	0.62227900	0.50836100	3.76382300
H	-1.11971300	0.14585700	2.61913400
C	2.00377900	0.71443600	3.73784000
H	3.80297300	0.83589300	2.50689400
H	2.48780600	0.88563200	4.69869700
C	-0.14384900	0.49549700	5.10557500
O	-1.37147700	0.26037900	5.02383500
O	0.55485300	0.71250200	6.12344900
C	1.80562100	0.06237200	-0.96441900
N	3.93945700	0.47217700	-0.20331000
C	0.04407000	3.44032600	-1.57320200
H	0.27737600	4.42487000	-2.00366200
H	-0.93600300	3.50598000	-1.08097300
H	0.79352000	3.19172600	-0.80904700
C	0.00051100	2.37139300	-2.66709700
H	-0.17005100	1.37633300	-2.03581700
H	1.03882000	2.15958700	-3.03724700
O	-0.91346500	2.52043300	-3.59980000



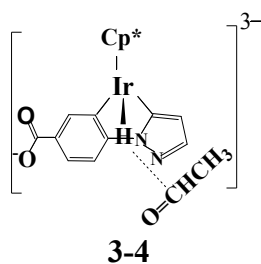
3-TS<sub>3.4</sub>

53 -116.71i cm<sup>-1</sup>

E=-1292.662625(au)

C	-1.32289800	-1.90537300	2.12182000
C	-1.91333100	-0.88536200	1.31445600
C	-2.83914500	-0.16448800	2.10744600
C	-1.87003800	-1.77841200	3.45801600
C	-2.73366500	-0.64296400	3.45791500
Ir	-0.37277400	-0.11872700	3.24835100
C	-1.59976200	-0.59551300	-0.11834400
H	-2.34991100	-1.02316900	-0.80279300
H	-1.55872200	0.48881000	-0.29582000
H	-0.62704200	-1.01801800	-0.40082900
C	-0.43872400	-3.00989300	1.64718400
H	0.22518600	-3.35673700	2.44855700
H	-1.01150200	-3.88061100	1.28625200
H	0.20753900	-2.67545700	0.82566400
C	-1.66397900	-2.74535500	4.57780300
H	-1.77785300	-2.25884800	5.55284400
H	-2.37935000	-3.58235000	4.52948100
H	-0.65128800	-3.16682400	4.55579800
C	-3.57026600	-0.15280600	4.59403500
H	-3.54130600	0.94211800	4.66026500
H	-4.62644600	-0.44895200	4.48323100
H	-3.21972300	-0.53615900	5.55838400
C	-3.57800400	1.06239900	1.70910900
H	-3.70734500	1.12409800	0.62290000
H	-4.56922200	1.10594200	2.18245000
H	-3.02037400	1.96782900	1.99975400
C	3.71410400	0.54694600	2.22272900
C	2.45270800	0.19494400	1.69274000
H	4.66059600	0.65902300	1.69888700
H	2.19795200	-0.01833100	0.65995700
N	2.37521400	0.53863300	3.84011200
C	0.39498900	0.31896400	5.08460000
C	1.78066900	0.60562000	5.11489300
C	-0.27172800	0.34499300	6.31797500
C	2.46336700	0.90267400	6.28299900

C	0.38508800	0.62457100	7.52214700
H	-1.34091500	0.14227100	6.39195000
C	1.75130600	0.90696300	7.48476500
H	3.53079300	1.11697200	6.23795000
H	2.23078400	1.12363800	8.43855900
C	-0.37481700	0.60412600	8.86793800
O	-1.59033900	0.30971500	8.79841500
O	0.31576300	0.87907500	9.87769200
C	1.57690900	0.19327800	2.77942400
N	3.67423100	0.75775900	3.53812800
C	0.05929400	3.58572100	2.06855000
H	0.53348200	4.44811700	1.56924600
H	-0.81921500	3.95369500	2.61069500
H	0.77154700	3.15745000	2.78299800
C	-0.36042900	2.57426900	1.02621000
H	-0.69675000	1.33355000	2.36479100
H	0.44577500	1.86800300	0.72666100
O	-1.34877200	2.75277900	0.29683100

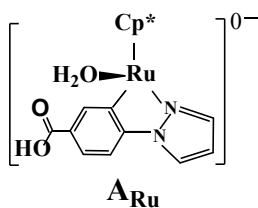


**53**

**E=-1292.663792(au)**

C	-1.05965800	-1.97904300	-1.53131700
C	-1.62923700	-0.97294700	-2.37137000
C	-2.64267200	-0.29577700	-1.64409300
C	-1.67448900	-1.86221800	-0.22211800
C	-2.55930800	-0.74798700	-0.27772000
Ir	-0.17388300	-0.19970500	-0.40935100
C	-1.27042400	-0.74074800	-3.80422700
H	-1.86768400	-1.36233800	-4.49136000
H	-1.41881000	0.30903800	-4.09024500
H	-0.21474400	-0.98217700	-3.98822100
C	-0.14264700	-3.07178200	-1.97044700
H	0.43794200	-3.46155200	-1.12536900
H	-0.68597200	-3.91729900	-2.42545300
H	0.58229900	-2.70599500	-2.70872200
C	-1.50972400	-2.82470000	0.90777400
H	-1.68472200	-2.34159900	1.87552000
H	-2.20438500	-3.67606500	0.82279500

H	-0.48817900	-3.22318700	0.94319300
C	-3.42792400	-0.24049700	0.82618900
H	-3.43733400	0.85663100	0.84233400
H	-4.47185700	-0.57822100	0.71686800
H	-3.07283800	-0.56794400	1.80920300
C	-3.33949300	0.94808100	-2.05637500
H	-3.33961300	1.08430800	-3.14394800
H	-4.37905700	0.97435300	-1.70032400
H	-2.81791400	1.82666300	-1.62831700
C	3.82811000	0.77740200	-1.53271700
C	2.58346100	0.34120600	-2.03635100
H	4.74446900	0.98517900	-2.08065300
H	2.31824100	0.13809800	-3.06906100
N	2.54940900	0.59935600	0.12451700
C	0.65033800	0.13003600	1.42947200
C	2.00420000	0.54233200	1.42358700
C	0.04099400	0.01966100	2.68704600
C	2.70742600	0.83649200	2.58059100
C	0.72133300	0.29045700	3.87967700
H	-1.00080200	-0.28872800	2.78762200
C	2.05231800	0.70480200	3.80695300
H	3.74811000	1.15183500	2.50811000
H	2.54914500	0.91275700	4.75372100
C	0.03021800	0.12468400	5.25189500
O	-1.15011800	-0.29336500	5.21817100
O	0.73440700	0.42315500	6.24587300
C	1.74389600	0.23118100	-0.92367700
N	3.81566100	0.93498300	-0.20889400
C	0.68490900	3.45089200	-2.15911300
H	1.59754900	3.76225900	-2.69167300
H	0.07049800	4.33492400	-1.96194900
H	0.99976300	2.97551600	-1.22443000
C	-0.06182200	2.47605200	-3.02320200
H	-0.70996900	1.34636600	-0.89674500
H	0.37345100	1.45571700	-3.04402500
O	-0.99815200	2.78080600	-3.74627900



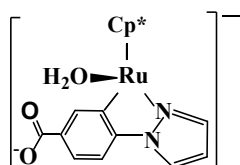
50

E=-1206.239655(au)



C	-1.22286100	-1.97009900	2.57400900
C	-1.68159500	-1.21648800	1.41849400
C	-2.76584100	-0.40442100	1.82727000
C	-2.10281100	-1.66053200	3.67620900
C	-3.02208800	-0.65584800	3.23741100
C	-1.09522600	-1.31115800	0.05072400
H	-1.52080300	-2.15374200	-0.51176100
H	-1.28037700	-0.39997500	-0.53112000
H	-0.01032400	-1.46834200	0.09250900
C	-0.15448000	-3.01039300	2.56429800
H	0.24534800	-3.17108600	3.57185900
H	-0.52366600	-3.97693000	2.19123200
H	0.68694200	-2.70792800	1.92893500
C	-2.07855500	-2.33065900	5.00685500
H	-2.58697800	-1.73822000	5.77496200
H	-2.58176600	-3.30601400	4.95891200
H	-1.05216000	-2.49888000	5.35145800
C	-4.13488600	-0.04613700	4.02184600
H	-4.28424000	1.00409100	3.74240400
H	-5.08821600	-0.56737700	3.85262600
H	-3.93118200	-0.07059100	5.09838100
C	-3.52780000	0.56989200	0.99522900
H	-3.01766000	0.77632000	0.04770300
H	-4.53270300	0.19369600	0.75725300
H	-3.65094900	1.52678800	1.51714400
C	3.06254700	1.23659500	2.80037000
C	2.90195200	1.22994400	1.43131300
C	1.56052800	0.87041400	1.22613100
N	0.94299800	0.66617600	2.38984300
H	3.92662400	1.45583000	3.41223300
H	3.65156600	1.44848400	0.68459100
H	1.00974800	0.73624700	0.30309500
N	1.87009500	0.90025300	3.35101800
C	0.07564900	0.39380000	4.83569500
C	1.42740800	0.78143500	4.69446000
C	-0.36552900	0.35702900	6.16647800
C	2.29018100	1.06267400	5.74812000
C	0.46826400	0.61914500	7.25870400
H	-1.40136000	0.10042900	6.39145600
C	1.80546100	0.97064900	7.04571200
H	3.32044900	1.36907800	5.57468100
H	2.45931500	1.23882100	7.87461500
C	-0.12532500	0.54515900	8.62194700
O	-1.30020100	0.67740900	8.85357900

O	0.74153400	0.31107900	9.63637600
H	1.60302200	0.06524300	9.27786300
O	-1.38405300	2.38970300	3.24976700
H	-0.56308100	2.81227800	2.96679000
H	-1.38364800	2.45374500	4.21465000
Ru	-0.99470900	0.08189200	3.07195800



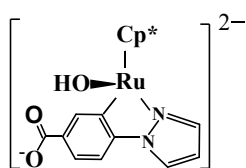
**B<sub>Ru</sub>**

**49**

**E=-1205.781482(au)**

C	-1.20920100	-1.96556500	2.36124700
C	-1.79582300	-1.13304200	1.32238500
C	-2.81392500	-0.35651300	1.93175600
C	-1.94974500	-1.75270800	3.58256000
C	-2.92288900	-0.72730200	3.33341500
C	-1.38702500	-1.12342600	-0.11230800
H	-1.89399700	-1.90798800	-0.69509100
H	-1.61333100	-0.16096600	-0.58863000
H	-0.30739800	-1.29399900	-0.21927700
C	-0.13502500	-2.97985400	2.15221300
H	0.40943400	-3.16952700	3.08424700
H	-0.53646800	-3.94031900	1.79378400
H	0.60049900	-2.63388900	1.41499500
C	-1.76263900	-2.50343700	4.85655000
H	-2.04697100	-1.90399300	5.72771200
H	-2.36786900	-3.42151300	4.86506700
H	-0.71387900	-2.78559200	5.00183600
C	-3.93680700	-0.19332600	4.28911200
H	-4.10947500	0.87769700	4.11905900
H	-4.90881700	-0.70171300	4.19463300
H	-3.60554500	-0.30041900	5.32836800
C	-3.65247900	0.69053200	1.28020400
H	-3.21572200	1.02759700	0.33278500
H	-4.66848700	0.32364100	1.07170300
H	-3.74767500	1.57126000	1.92682700
C	3.18719800	0.94617000	2.92364100
C	3.11256200	0.86742600	1.54327700
C	1.76656800	0.59239900	1.27344500
N	1.06665400	0.50493000	2.40988400
H	4.02196100	1.13890600	3.58331200

H	3.92140700	0.98927300	0.83658500
H	1.25925400	0.44327600	0.32716100
N	1.94680900	0.73000300	3.41267800
C	0.05086700	0.38082500	4.81521000
C	1.41383300	0.72143400	4.73782100
C	-0.49756700	0.46082500	6.10444900
C	2.20213300	1.06291900	5.83593500
C	0.24551600	0.80624200	7.23601800
H	-1.55293300	0.24508100	6.28809200
C	1.60439900	1.09438600	7.08922700
H	3.25805300	1.31445700	5.71706600
H	2.15195200	1.35557000	7.99280000
C	-0.42039200	0.88147800	8.63294500
O	-1.64287400	0.62254000	8.64826800
O	0.35351700	1.19606000	9.56205100
O	-1.20708800	2.37510200	3.25695900
H	-0.31775300	2.68999900	3.05042900
H	-1.20014000	2.27453700	4.22436900
Ru	-0.93229800	0.03675100	3.00671900



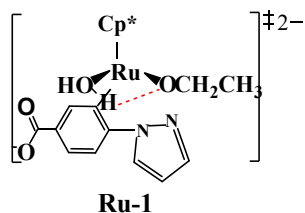
$C_{Ru}$

48

$E=-1205.293392(\text{au})$

C	-1.22835400	-2.02861300	2.31297300
C	-1.81976200	-1.14839000	1.31591900
C	-2.78313500	-0.34311000	1.98265900
C	-1.88576900	-1.78952800	3.57111200
C	-2.84426000	-0.71989000	3.37537400
C	-1.47724000	-1.11850800	-0.13625200
H	-2.10831200	-1.78870900	-0.74802600
H	-1.57577800	-0.10496700	-0.54768900
H	-0.43586600	-1.43001500	-0.30083000
C	-0.21126200	-3.08233800	2.02390900
H	0.30637000	-3.38718800	2.94157100
H	-0.64774000	-3.98850500	1.56575100
H	0.56046200	-2.70779200	1.33613800
C	-1.69353900	-2.55666900	4.83598700
H	-1.73173800	-1.89705400	5.71192300
H	-2.45832900	-3.34017300	4.96684100
H	-0.70794700	-3.03867200	4.85607700

C	-3.80104500	-0.17049300	4.37920200
H	-3.88631400	0.91942400	4.27568700
H	-4.81503800	-0.59909500	4.28654900
H	-3.45453800	-0.36215800	5.40204100
C	-3.52613600	0.81365600	1.40143900
H	-3.49356800	0.80664500	0.30410600
H	-4.58247800	0.81128000	1.70740400
H	-3.04374000	1.73887400	1.76362500
C	3.19260200	1.13816300	3.00275800
C	3.18176400	0.93193900	1.63440200
C	1.89198600	0.45620800	1.35302700
N	1.16999000	0.36263500	2.47400200
H	3.95763200	1.51639400	3.66724900
H	3.99223400	1.11091300	0.93926200
H	1.43780000	0.18541500	0.40705000
N	1.96902400	0.79242200	3.47290800
C	0.03785800	0.44339700	4.81814900
C	1.39698200	0.81099800	4.77358400
C	-0.51761700	0.48527300	6.11372500
C	2.16406600	1.15135000	5.88959300
C	0.20441800	0.81009000	7.26476500
H	-1.57366200	0.25574100	6.26866500
C	1.55853200	1.14419200	7.13726600
H	3.21972100	1.41744200	5.78547800
H	2.09544100	1.39677300	8.05005000
C	-0.44737700	0.80371800	8.66798100
O	-1.65244100	0.46707700	8.71261800
O	0.31154700	1.13481000	9.61209100
O	-1.08244700	2.07812700	2.72100300
H	-0.94523300	2.44644200	3.60036700
Ru	-0.83683800	-0.01092500	2.99229500



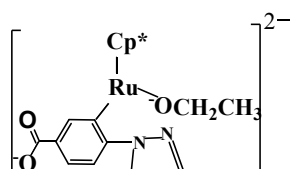
**57**

**E=-1360.275796(au)**

C	-1.00414000	-1.61282700	1.97084400
C	-2.10051600	-0.90425800	1.33082700
C	-3.07189000	-0.61806800	2.32848800
C	-1.36627800	-1.83704900	3.35618600
C	-2.62889300	-1.19758700	3.59173200

C	-2.08388300	-0.44003100	-0.08608700
H	-2.12023000	-1.27599400	-0.80374500
H	-2.93386000	0.22099300	-0.29624700
H	-1.17472500	0.14735700	-0.27972400
C	0.14982000	-2.21619700	1.24534100
H	0.99462800	-2.37402000	1.92272800
H	-0.12156600	-3.18368000	0.78607800
H	0.49534900	-1.55369100	0.44046700
C	-0.56779100	-2.61594400	4.34692500
H	-0.76257700	-2.26460000	5.36720100
H	-0.80662300	-3.69171400	4.30569700
H	0.50596200	-2.48383900	4.16594400
C	-3.40252900	-1.16724000	4.86652300
H	-3.94943200	-0.22091200	4.96806900
H	-4.13574700	-1.98895800	4.93491000
H	-2.73873500	-1.22855200	5.73626200
C	-4.32410900	0.17468900	2.16401800
H	-4.29051200	0.78185500	1.25088400
H	-5.21992900	-0.46610300	2.11901000
H	-4.44254100	0.87331800	3.00043800
C	3.40471700	0.86952200	3.37418100
C	4.18009800	0.03876100	2.58894200
C	3.51910600	-1.19847300	2.66515000
N	2.43863000	-1.13892100	3.44192100
H	3.48579500	1.92012400	3.62333800
H	5.06738900	0.30019700	2.02682100
H	3.77731600	-2.13814500	2.18547800
N	2.37241200	0.13850400	3.85455800
C	0.05127300	0.69370300	4.63733200
C	1.43708600	0.58967000	4.86762700
C	-0.65069300	1.13683900	5.79334700
C	2.05655300	0.91986100	6.08278300
C	-0.07648000	1.48546300	7.01703300
H	-1.74137900	1.21032100	5.77639100
C	1.30905900	1.37792200	7.15273000
H	3.13907800	0.79242200	6.16644600
H	1.74947700	1.64468500	8.11168400
C	-0.93485200	1.96943300	8.21125400
O	-2.16924500	2.02232000	8.01153900
O	-0.28999200	2.25596800	9.24858200
O	-2.28192000	2.46319000	3.50204400
H	-1.80492400	2.58683300	4.33400800
C	1.58081800	1.59481900	0.64546700
H	1.59550000	0.53872500	0.94672900

H	1.12721100	1.65342600	-0.35555900
H	2.62091300	1.95091500	0.58756400
C	0.74165500	2.39188500	1.63801100
H	1.25883300	2.37980600	2.62271300
H	0.75491300	3.45865600	1.30686700
O	-0.54325400	1.91754600	1.71361400
H	-1.59695100	2.56966200	2.78036700
Ru	-1.19396700	0.24726200	2.96014300



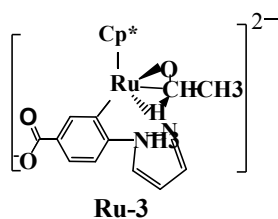
Ru-2

54

E=-1283.84222(au)

C	-1.27540600	-1.99907300	2.42843200
C	-2.13064100	-1.30748700	1.46926600
C	-3.13799700	-0.62709800	2.20798000
C	-1.81723200	-1.81089700	3.74579800
C	-2.92551200	-0.90313800	3.62525500
C	-1.88368000	-1.22661500	0.00120300
H	-2.28815100	-2.08595100	-0.55996400
H	-2.31885900	-0.30927000	-0.41510000
H	-0.80433200	-1.17023900	-0.19672300
C	-0.12104600	-2.87749700	2.08400600
H	0.64273200	-2.83536100	2.86744400
H	-0.43268600	-3.92747700	1.94647700
H	0.36977500	-2.54227000	1.16207700
C	-1.29283400	-2.40688000	5.00977400
H	-1.49266700	-1.76229700	5.87531700
H	-1.73178200	-3.39753800	5.21089300
H	-0.20235400	-2.52090900	4.96059300
C	-3.82086200	-0.44502700	4.72823200
H	-4.17586200	0.57707900	4.54274500
H	-4.70858200	-1.09332800	4.82278300
H	-3.31096100	-0.43049300	5.69952200
C	-4.19071400	0.28248600	1.67248600
H	-3.94898600	0.60648100	0.65289300
H	-5.18919300	-0.18558700	1.65532500
H	-4.25465000	1.19068500	2.28637800
C	3.13733800	1.46322400	2.82531900
C	3.68949900	0.97778800	1.65504900
C	3.04852700	-0.26040900	1.47507800

N	2.18764300	-0.52300700	2.45685400
H	3.27144500	2.39301800	3.36433400
H	4.41997800	1.46225600	1.01961000
H	3.17642000	-0.98316400	0.67478600
N	2.24826900	0.54430800	3.26957900
C	0.07704500	0.59230700	4.46299900
C	1.48170200	0.64020700	4.49178900
C	-0.50376400	0.72805900	5.74550500
C	2.23442500	0.80539400	5.66376400
C	0.19823400	0.85650000	6.94137100
H	-1.58743500	0.70957700	5.84760300
C	1.59436600	0.91427500	6.88897500
H	3.32565900	0.81290600	5.59264200
H	2.13499200	1.02090000	7.82816900
C	-0.54128400	0.86144900	8.29705500
O	-1.76085600	0.56993300	8.25036400
O	0.16445300	1.13442100	9.29735700
C	0.73800100	3.27744100	0.92239400
H	1.41907500	2.45170100	0.67532200
H	0.12634900	3.49116900	0.03437900
H	1.34124900	4.16947200	1.15691800
C	-0.15168200	2.86676900	2.09100300
H	0.49155200	2.70296600	2.97910700
H	-0.79981700	3.73731500	2.35167600
O	-0.90595200	1.76478400	1.76374300
Ru	-1.19717100	0.07706000	2.87012800



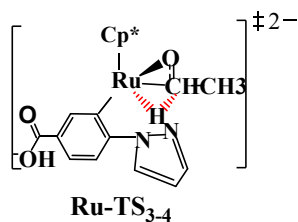
**54**

**E=-1283.837452(au)**

C	-0.37834900	-1.83761600	-1.59902300
C	-1.44112300	-1.21098700	-2.36917700
C	-2.45852100	-0.80083600	-1.46373900
C	-0.78108900	-1.86269800	-0.22438000
C	-2.05469200	-1.18337300	-0.11853500
C	-1.42229000	-1.04502100	-3.85207900
H	-1.61127700	-1.99429800	-4.38191500
H	-2.18247500	-0.32670400	-4.18510500
H	-0.44721900	-0.67046200	-4.19591700
C	0.84477000	-2.46589900	-2.17999900

H	1.65510900	-2.51107700	-1.44237600
H	0.65408800	-3.49072900	-2.54549500
H	1.22510700	-1.87818300	-3.02651500
C	-0.05958300	-2.51399500	0.90798800
H	-0.20592900	-1.95358500	1.83919700
H	-0.42241700	-3.54228700	1.06817800
H	1.02189200	-2.55488900	0.73016600
C	-2.87670300	-1.03283700	1.11866400
H	-3.59450100	-0.20999400	1.01015700
H	-3.45090800	-1.94763500	1.34497500
H	-2.26770200	-0.78662000	1.99782800
C	-3.69629200	-0.03410800	-1.78613700
H	-3.63677900	0.40940900	-2.78827100
H	-4.60482100	-0.65595600	-1.74063700
H	-3.81406100	0.79849100	-1.08091800
C	3.04995800	0.57614500	-1.05141300
C	3.97531300	-0.13122300	-1.79785800
C	4.17751300	-1.30456900	-1.05362000
N	3.43835000	-1.32471000	0.05696300
H	2.59061700	1.54592400	-1.19048900
H	4.43120600	0.16601600	-2.73368900
H	4.82601200	-2.14657700	-1.27687900
N	2.75338500	-0.16344100	0.03840000
C	0.54578000	0.61003700	0.86047800
C	1.87031500	0.21464400	1.11958800
C	-0.17659200	0.96920200	2.02179400
C	2.41847000	0.12898500	2.40524200
C	0.31091800	0.85306400	3.32500500
H	-1.21053400	1.30200000	1.92055300
C	1.63448000	0.43443000	3.50488700
H	3.45549500	-0.19395500	2.51280700
H	2.00704600	0.37101600	4.52605800
C	-0.58269700	1.11990600	4.55710500
O	-1.80948200	1.22830500	4.32681800
O	0.01980100	1.17685300	5.65663300
C	-0.38397300	2.77556900	-3.16964800
H	-1.10039200	2.06894200	-3.60854200
H	-0.83659900	3.77607400	-3.18925700
H	0.52861100	2.78997500	-3.78674300
C	-0.10005200	2.36556500	-1.72508700
H	0.51971900	1.36486900	-1.84188000
H	0.69368800	3.03454400	-1.29677000
O	-1.19196100	2.24960400	-0.95656400
Ru	-0.60661900	0.18069000	-0.85605300



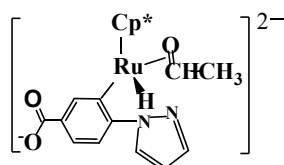


**54 -648.80i cm<sup>-1</sup>**

**E=-1283.827457(au)**

C	-0.91832000	-1.55223700	2.13027600
C	-1.98309400	-0.92224500	1.37544400
C	-2.98053100	-0.51280400	2.30767100
C	-1.30881200	-1.58813200	3.50987900
C	-2.58394300	-0.93812100	3.63700600
C	-2.00928900	-0.77518400	-0.10925700
H	-2.29009400	-1.71090300	-0.62285900
H	-2.72574100	-0.00466500	-0.42409900
H	-1.02494400	-0.47526500	-0.49616100
C	0.30413200	-2.18126000	1.54611600
H	1.13790500	-2.16262600	2.25882000
H	0.13074400	-3.23031600	1.24771800
H	0.63904600	-1.63381100	0.65503800
C	-0.56157900	-2.23668600	4.62740700
H	-0.70739900	-1.68739600	5.56543000
H	-0.90353300	-3.27285700	4.78179700
H	0.51808900	-2.25567000	4.43593300
C	-3.39122500	-0.79937800	4.88614900
H	-4.12596400	0.00976300	4.78585900
H	-3.94815300	-1.72082200	5.12913600
H	-2.77574300	-0.53809000	5.75708100
C	-4.22952100	0.24738100	2.00716500
H	-4.19852900	0.68110100	0.99956300
H	-5.13213900	-0.38040900	2.07839600
H	-4.33908500	1.08291700	2.71022300
C	2.63361500	0.91049200	2.69617500
C	3.55873500	0.20133200	1.95177000
C	3.70906400	-0.99998500	2.66360600
N	2.94173300	-1.03289400	3.75412100
H	2.20272200	1.89570500	2.57218400
H	4.04602800	0.51350500	1.03686400
H	4.34026900	-1.85249600	2.43079600
N	2.28890400	0.14738000	3.75450100
C	0.06061700	0.88761400	4.57552000
C	1.39403400	0.51564800	4.82897800
C	-0.66267600	1.23637400	5.73993900

C	1.94340100	0.43715600	6.11534500
C	-0.16854200	1.13443000	7.04147100
H	-1.70286000	1.55067100	5.64345100
C	1.16093500	0.73400500	7.21782400
H	2.98451200	0.12603600	6.21963600
H	1.53843500	0.67681300	8.23751200
C	-1.06055000	1.39990300	8.27539700
O	-2.28831700	1.50328000	8.04859400
O	-0.45476700	1.46271900	9.37278700
C	-0.90430700	2.74378000	0.58313500
H	-1.76322200	2.14975300	0.24700000
H	-1.12528400	3.80723500	0.40189100
H	-0.02441200	2.46210900	-0.01488300
C	-0.67382200	2.50244700	2.06782700
H	0.13419800	1.23464800	2.01558100
H	0.22882400	3.05449200	2.42823400
O	-1.71997000	2.56667800	2.85462500
Ru	-1.09544400	0.49426700	2.87160000



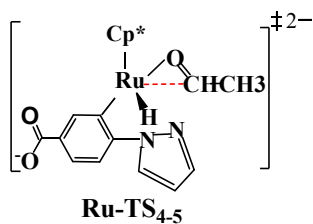
Ru-4

54

E=-1283.835304(au)

C	-0.55033300	-1.92441000	-1.15003400
C	-1.34191700	-1.29987200	-2.19733000
C	-2.45535000	-0.67006000	-1.56574200
C	-1.24525500	-1.75441200	0.09814700
C	-2.37686900	-0.94394400	-0.14106500
C	-1.08633400	-1.41991400	-3.66397900
H	-1.48839700	-2.35750100	-4.08604200
H	-1.53785900	-0.58670500	-4.21778800
H	-0.01021900	-1.39491300	-3.87425500
C	0.65775200	-2.78090300	-1.35292400
H	1.36102300	-2.68073400	-0.51752600
H	0.40017000	-3.84957000	-1.45290300
H	1.20701500	-2.47849400	-2.25323500
C	-0.80598500	-2.31340200	1.41111900
H	-1.16490700	-1.72400300	2.26580800
H	-1.16460200	-3.34867300	1.52712100
H	0.28833100	-2.33267500	1.48197100
C	-3.32829000	-0.41611900	0.88436400

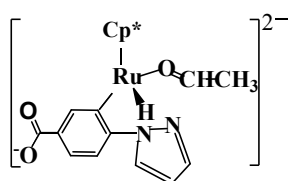
H	-3.57617000	0.63197800	0.66864500
H	-4.27283400	-0.98414300	0.89720300
H	-2.89697400	-0.43707600	1.89501200
C	-3.59091500	0.04878000	-2.21433300
H	-3.39695100	0.22636100	-3.28031900
H	-4.53511100	-0.51601400	-2.14021600
H	-3.75709000	1.02762800	-1.74306000
C	3.16029200	1.05638500	-1.22147300
C	4.12318000	0.56915500	-2.08494600
C	4.52366100	-0.64046500	-1.49149400
N	3.86868000	-0.88135200	-0.35629800
H	2.54157400	1.94418100	-1.24390000
H	4.47085900	1.02163200	-3.00484000
H	5.26763900	-1.35204600	-1.83797700
N	3.03836000	0.17071200	-0.20960700
C	0.77774900	0.54993500	0.73721600
C	2.14741900	0.28244500	0.91639900
C	0.05625700	0.66476600	1.94450300
C	2.72725200	0.08619700	2.17768800
C	0.57116800	0.38509900	3.20733600
H	-1.01104500	0.87889400	1.89790300
C	1.94001700	0.11822400	3.31816000
H	3.79720700	-0.12112400	2.22846700
H	2.34647200	-0.07023200	4.31091400
C	-0.36186500	0.22766800	4.42047400
O	-1.56879000	-0.00310900	4.14273700
O	0.18053300	0.29932400	5.54638100
C	-1.02331000	2.52228500	-2.93818500
H	-1.98124100	2.00788900	-3.08392700
H	-1.19925600	3.60599600	-3.06971300
H	-0.32690500	2.19387300	-3.72336100
C	-0.45755600	2.20756900	-1.56911900
H	0.84867400	0.23381200	-1.70331500
H	0.53302300	2.68638900	-1.40866400
O	-1.26144400	2.19463800	-0.52579900
Ru	-0.51929100	0.25154700	-0.86415500



**54** -101.23i cm<sup>-1</sup>  
**E=-1283.803339(au)**

C	-0.22440900	-1.98282500	-1.51626800
C	-1.25138400	-1.44044100	-2.39188100
C	-2.36959200	-1.09528700	-1.57936800
C	-0.78130800	-2.03411500	-0.17484300
C	-2.09821100	-1.49132800	-0.20552500
C	-1.13737800	-1.31782300	-3.87471100
H	-1.36104500	-2.26482500	-4.39833100
H	-1.82179400	-0.55186400	-4.26219900
H	-0.12320600	-1.01048900	-4.15859800
C	1.03443900	-2.64081500	-1.96961100
H	1.81665300	-2.59342000	-1.20285400
H	0.87430600	-3.70425000	-2.22546300
H	1.44148000	-2.14130400	-2.85821200
C	-0.08046400	-2.58600400	1.02292700
H	-0.38621500	-2.06770500	1.94003700
H	-0.28094000	-3.66214600	1.14967700
H	1.00467200	-2.44799100	0.94434400
C	-3.03936900	-1.32484100	0.93961200
H	-3.59143800	-0.37844700	0.85965500
H	-3.78458100	-2.13736900	1.00362300
H	-2.50331900	-1.28663800	1.89492100
C	-3.63822300	-0.45201200	-2.02958100
H	-3.51437200	0.00729400	-3.01869900
H	-4.47608100	-1.16758900	-2.08624500
H	-3.92881500	0.35089000	-1.33978500
C	2.96785700	-0.01576000	-1.11813300
C	4.03056000	-0.74243100	-1.62531800
C	4.45459800	-1.52888400	-0.54195800
N	3.72199300	-1.31033600	0.54982600
H	2.25143600	0.66826500	-1.56232400
H	4.41658000	-0.71691900	-2.63684100
H	5.26105200	-2.25601100	-0.50287300
N	2.81699600	-0.37920000	0.17565100
C	0.57836100	0.53101100	0.79196200
C	1.90205300	0.19485000	1.14002900
C	-0.14704800	1.10566100	1.86897000
C	2.43671600	0.38087600	2.42186000
C	0.34686400	1.31907500	3.15665900
H	-1.19318300	1.38751700	1.72706600
C	1.66287400	0.93508700	3.42747800
H	3.46932300	0.08140400	2.60087500
H	2.04251300	1.10054800	4.43443400
C	-0.51522000	1.97199700	4.26181000
O	-1.67266900	2.31747300	3.92688000

O	0.04642500	2.09387200	5.37764500
C	-1.29862600	4.18784100	-1.33266000
H	-2.29868400	4.25218400	-1.77226700
H	-1.09199200	5.05854900	-0.70021400
H	-0.55394100	4.18083100	-2.14265600
C	-1.13592200	2.90837300	-0.57644500
H	0.33921200	1.01848400	-1.90221900
H	-0.25165900	2.81177700	0.07894100
O	-1.91362500	1.97346500	-0.70631700
Ru	-0.60830500	0.01349900	-0.88973400



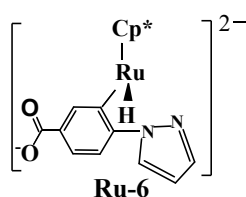
Ru-5

54

**E=-1283.80592(au)**

C	-0.36638900	-2.10391800	-1.01637400
C	-1.02407000	-1.63498900	-2.21832200
C	-2.35399000	-1.21369600	-1.88100600
C	-1.31455300	-1.98471400	0.07705700
C	-2.49507800	-1.38313700	-0.44848300
C	-0.44028800	-1.70002900	-3.59170100
H	-0.63394800	-2.67018900	-4.08178200
H	-0.85011300	-0.90899500	-4.23248300
H	0.64680000	-1.55417900	-3.55781300
C	0.93425700	-2.83214500	-0.94214700
H	1.42710200	-2.66488100	0.02380300
H	0.80079000	-3.92240000	-1.06287500
H	1.63687200	-2.49203300	-1.71331300
C	-1.05411800	-2.40162600	1.48451700
H	-1.74131100	-1.90829200	2.18306400
H	-1.15787400	-3.49113100	1.62710900
H	-0.04000300	-2.11902000	1.79641000
C	-3.70547400	-0.99017200	0.33233300
H	-4.13882300	-0.06333700	-0.06499200
H	-4.49037900	-1.76418800	0.31107500
H	-3.45074800	-0.79118400	1.38080800
C	-3.41485200	-0.73267600	-2.81312300
H	-2.97232000	-0.30235600	-3.72095100
H	-4.11414200	-1.52974600	-3.13085800
H	-4.01655700	0.06074900	-2.34913600
C	2.58886500	0.02486300	-1.76571000

C	3.59557800	-0.64124000	-2.44350200
C	4.38605700	-1.19637100	-1.42282300
N	3.91517800	-0.90215900	-0.21281400
H	1.69745400	0.56258100	-2.08029200
H	3.72090400	-0.71557200	-3.51688700
H	5.28149200	-1.80585500	-1.50956600
N	2.81176200	-0.15576400	-0.44386100
C	0.65866400	0.53244200	0.63038700
C	2.06556300	0.40726400	0.66250900
C	0.14518700	1.09289600	1.83184900
C	2.85848600	0.82880400	1.74008900
C	0.89587200	1.57010700	2.90678600
H	-0.93424200	1.16929700	1.96450900
C	2.28254400	1.41450400	2.85470300
H	3.93732600	0.69421800	1.66816700
H	2.87367400	1.76401100	3.69944900
C	0.23749400	2.28302400	4.09836600
O	-0.95772000	2.66023400	3.93128600
O	0.95151400	2.44480000	5.11103600
C	-1.97248500	3.75851700	1.21723700
H	-3.06349900	3.66287000	1.23087100
H	-1.58012200	3.45840900	2.22344200
H	-1.66874200	4.79470700	1.02397200
C	-1.37199600	2.81470800	0.24787800
H	-0.06633800	1.07682100	-1.87780400
H	-0.33090700	3.00483700	-0.07581100
O	-1.94536100	1.80547600	-0.15306400
Ru	-0.80218300	-0.01815800	-0.82113500

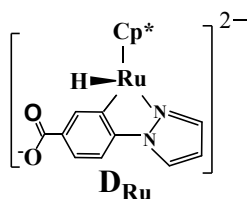


**47**

**E=-1130.021652(au)**

C	-0.35255100	-2.18266500	-0.91906800
C	-0.98215600	-1.77417900	-2.17371400
C	-2.25076000	-1.18750400	-1.88026200
C	-1.21893800	-1.81910200	0.15148600
C	-2.33861300	-1.10613400	-0.43629200
C	-0.41042900	-2.03174800	-3.52835000
H	-0.60684600	-3.06033400	-3.87762200
H	-0.82847400	-1.33746600	-4.26782000
H	0.67702900	-1.88296600	-3.52500600

C	0.96346200	-2.87721600	-0.80592600
H	1.45754100	-2.63704900	0.14315500
H	0.86452000	-3.97358200	-0.87412100
H	1.65156300	-2.55071500	-1.59698000
C	-0.99133800	-2.02509600	1.61147500
H	-1.26652200	-1.13790400	2.19852800
H	-1.56333600	-2.88276600	2.00075100
H	0.07016700	-2.20283400	1.82257600
C	-3.47066000	-0.52787500	0.34318600
H	-3.95425200	0.28594900	-0.21079400
H	-4.23879100	-1.28518800	0.57575300
H	-3.11325900	-0.10803500	1.29126800
C	-3.25689700	-0.67367600	-2.85320000
H	-2.77998200	-0.40625500	-3.80495000
H	-4.05901700	-1.40062600	-3.07150800
H	-3.73044900	0.24194400	-2.47592500
C	2.47841100	0.20673700	-1.81754100
C	3.43493800	-0.43645000	-2.58595800
C	4.30202900	-1.00810400	-1.64085600
N	3.91598900	-0.75131600	-0.39097800
H	1.59580700	0.78673400	-2.08079200
H	3.48758500	-0.47224100	-3.66696100
H	5.19630000	-1.60151600	-1.80953400
N	2.79851700	-0.00830400	-0.51963500
C	0.68430800	0.69676200	0.52180000
C	2.06568100	0.46362700	0.63310500
C	0.08331200	1.15522700	1.71673600
C	2.78722000	0.63595900	1.82000600
C	0.74856600	1.29029900	2.93528000
H	-0.98826300	1.36250000	1.74002700
C	2.12426300	1.03743100	2.96940500
H	3.85724100	0.42952300	1.81857500
H	2.63683500	1.16895200	3.92114100
C	-0.01156500	1.65001900	4.23050700
O	-1.26322700	1.61576800	4.15616900
O	0.70795300	1.91895600	5.22283000
H	-0.63192100	1.44992500	-1.84425100
Ru	-0.60280600	-0.03679700	-0.97261500

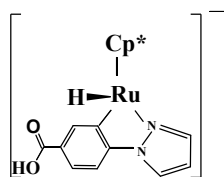


**E=-1130.046411(au)**

C	-1.25886900	-2.02977800	2.28758200
C	-1.82240200	-1.10218700	1.32739200
C	-2.77286600	-0.29608000	2.02305700
C	-1.88011400	-1.80093000	3.55367100
C	-2.82440500	-0.71470400	3.40376900
C	-1.54664000	-1.10320200	-0.13925700
H	-2.17987500	-1.81859500	-0.69875800
H	-1.70969100	-0.10969900	-0.57812500
H	-0.50274900	-1.37846200	-0.34655400
C	-0.23000000	-3.06145500	1.96500200
H	0.25921700	-3.42767600	2.87608700
H	-0.64913400	-3.93627500	1.43627300
H	0.56217600	-2.64714200	1.32331400
C	-1.64866400	-2.55762600	4.81867300
H	-1.59550500	-1.87939500	5.68060900
H	-2.44572600	-3.29339900	5.01686700
H	-0.69333700	-3.09681700	4.78676500
C	-3.80133800	-0.25255800	4.43246100
H	-4.00053000	0.82195500	4.33384400
H	-4.76971100	-0.78194000	4.36968700
H	-3.40977500	-0.40310300	5.44577300
C	-3.65228600	0.74528200	1.41233600
H	-3.16366700	1.22274300	0.55324300
H	-4.61540100	0.32904100	1.06783400
H	-3.86908900	1.53940900	2.13624600
C	3.23482300	1.07835300	3.04812700
C	3.22988400	0.86398000	1.68079300
C	1.91651700	0.47667700	1.37780000
N	1.16198200	0.45160900	2.48830600
H	4.01637300	1.39575200	3.72501500
H	4.06274300	0.97998700	0.99849900
H	1.45823500	0.24038100	0.42500500
N	1.98121300	0.81684300	3.50208300
C	0.02161400	0.53868400	4.81358100
C	1.39797200	0.84863600	4.79283600
C	-0.54118000	0.57150700	6.10950800
C	2.16302300	1.15264700	5.92186000
C	0.17941300	0.85460000	7.27029900
H	-1.60604000	0.37774300	6.25081600
C	1.54597600	1.15118800	7.16268700
H	3.22872000	1.38272800	5.83056100
H	2.08082400	1.37495400	8.08404700
H	-1.01092100	1.71103100	2.94990900



C	-0.48622200	0.85087500	8.66702600
O	-1.70346800	0.55774100	8.69812600
O	0.27374800	1.14139700	9.62428900
Ru	-0.82900500	0.06664000	2.99096000



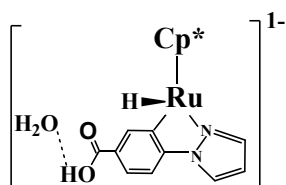
$E_{Ru}$

48

$E=-1130.5043698(\text{au})$

C	2.29483800	-0.74033600	1.29159200
C	3.02782900	-0.71990000	0.04354000
C	2.37500700	-1.61554800	-0.85087100
C	1.21260900	-1.66394000	1.15840900
C	1.24408300	-2.20653400	-0.17993100
C	4.29844500	0.02279000	-0.20512000
H	5.19241600	-0.56246200	0.06975700
H	4.39982600	0.30120700	-1.26185800
H	4.33710700	0.95151300	0.37987900
C	2.66841300	0.03440900	2.51108200
H	1.82874300	0.09607000	3.21350000
H	3.52058300	-0.41228500	3.04907800
H	2.95036900	1.06653700	2.25926900
C	0.23631300	-2.05490700	2.21733900
H	-0.77320700	-2.17771800	1.80446500
H	0.51147500	-3.00279900	2.70554900
H	0.16620900	-1.28466500	2.99494000
C	0.39359100	-3.31605900	-0.70224800
H	0.16815300	-3.17618900	-1.76680900
H	0.87045600	-4.30390900	-0.58717200
H	-0.56776500	-3.36058200	-0.17506200
C	2.82535900	-1.96078600	-2.23190400
H	3.34297600	-1.11787500	-2.70513200
H	3.51074800	-2.82348900	-2.23359200
H	1.96994200	-2.20971100	-2.86992900
C	-0.35770300	3.93826700	-0.06917000
C	0.97707100	4.27578300	-0.12415300
C	1.66730000	3.05448400	-0.20171900
N	0.81173700	2.02488800	-0.19150600
H	-1.24956100	4.54675500	-0.01297000
H	1.39758200	5.27240300	-0.11707700
H	2.72885800	2.86066600	-0.29120100

N	-0.42786500	2.57694900	-0.10596300
C	-1.09296400	0.30475900	-0.15459700
C	-1.49800800	1.66652500	-0.06607800
C	-2.17879800	-0.59606000	-0.10888500
C	-2.81069600	2.10564400	0.06509200
C	-3.51014900	-0.19657100	0.00913600
H	-1.99075600	-1.66656600	-0.20493900
C	-3.83561400	1.17020000	0.09937300
H	-3.04065100	3.16791900	0.15505800
H	-4.85912400	1.50123100	0.27624700
H	0.55228900	0.18371100	-1.92418100
C	-4.56314600	-1.23728900	0.01610300
O	-4.42353700	-2.38457500	0.36539100
O	-5.78613100	-0.82491500	-0.43168600
Ru	0.89668800	-0.04622200	-0.32814600
H	-5.67337300	0.05747000	-0.80871200



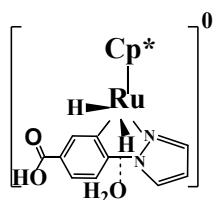
$E_{Ru'}$

**51**

**E=-1206.940329(au)**

C	-0.97591100	-2.05880400	2.87118700
C	-1.52816700	-1.41615600	1.69761500
C	-2.64017700	-0.63312900	2.11885500
C	-1.76625600	-1.67731400	3.99879300
C	-2.79987900	-0.77558000	3.54537800
C	-1.05667500	-1.62296700	0.29699700
H	-1.52919800	-2.49440100	-0.18633700
H	-1.26601600	-0.74541900	-0.32763200
H	0.02846100	-1.79176000	0.26363200
C	0.18890100	-2.99148800	2.85875700
H	0.60409000	-3.12500300	3.86491600
H	-0.07342300	-3.98950800	2.47144700
H	1.00181600	-2.60305100	2.22884800
C	-1.60892700	-2.16005500	5.40245900
H	-1.76359900	-1.34308600	6.12216300
H	-2.33073600	-2.95212800	5.65456800
H	-0.60237000	-2.56490600	5.57354700
C	-3.94464200	-0.26581900	4.35550600
H	-4.25588700	0.73087800	4.01978000

H	-4.82573900	-0.92716200	4.30303800
H	-3.67575000	-0.17326200	5.41546000
C	-3.54697200	0.15629800	1.23296200
H	-3.01910000	0.51452500	0.34141900
H	-4.41216600	-0.43835400	0.89937700
H	-3.92795100	1.04152600	1.75436600
C	3.01353200	1.76246100	3.15051000
C	3.12751000	1.25956100	1.87202200
C	1.90346800	0.61986200	1.61378600
N	1.08650900	0.72029200	2.66864900
H	3.69773600	2.33903800	3.75758700
H	3.97854600	1.35014600	1.21067300
H	1.55269500	0.11435700	0.72223900
N	1.77633800	1.41856800	3.60639100
C	-0.22717300	1.11956400	4.83708200
C	1.10747000	1.61791200	4.82830600
C	-0.88931800	1.33317100	6.06982300
C	1.74744500	2.21190100	5.91135500
C	-0.26187100	1.87173700	7.19042400
H	-1.93464000	1.03292400	6.17329200
C	1.06989100	2.31559800	7.12332800
H	2.77229000	2.57592900	5.82710200
H	1.55479500	2.74073400	8.00054200
H	-1.24920200	1.69743900	2.70216000
C	-0.97164500	1.84422300	8.50030100
O	-2.05087800	2.33749700	8.72516400
O	-0.30238300	1.17759500	9.46778500
H	0.37875000	0.60862200	9.04958400
O	1.26159300	-0.64127500	7.87326600
H	0.49265700	-0.83694500	7.32154800
H	1.68259800	0.07514900	7.37359500
Ru	-0.85520700	0.16797600	3.16711700



**Ru-7'**

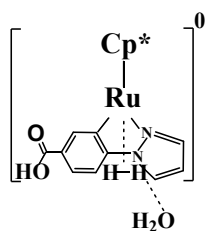
**52**

**E=-1207.424877 (au)**

C	-0.57490400	-1.71923800	-1.24704500
C	-1.07079500	-1.03114400	-2.42759600
C	-2.26444800	-0.34869900	-2.06909300
C	-1.49084400	-1.48209600	-0.18156600

C	-2.50087300	-0.58668000	-0.66695800
C	-0.49747000	-1.15777800	-3.79927200
H	-0.87313900	-2.06551800	-4.29083900
H	-0.75113500	-0.29725700	-4.42621400
H	0.59572500	-1.23408800	-3.77203600
C	0.63530100	-2.59142100	-1.19559200
H	1.06797400	-2.60930200	-0.18839100
H	0.40361700	-3.62735300	-1.47764800
H	1.41405400	-2.23197300	-1.87919300
C	-1.44485300	-2.09467000	1.17607500
H	-1.83112900	-1.42505300	1.95244600
H	-2.05181500	-3.00960000	1.20044300
H	-0.42379400	-2.36541600	1.46465300
C	-3.70926300	-0.15117900	0.09417600
H	-4.07586200	0.81942900	-0.25518500
H	-4.52412800	-0.87845300	-0.02270500
H	-3.50078400	-0.05717000	1.16493300
C	-3.16474700	0.41535400	-2.98240100
H	-2.60719500	0.87682600	-3.80400500
H	-3.93243400	-0.24181400	-3.41327400
H	-3.68235000	1.21796900	-2.44538300
C	3.63383100	0.70356700	-1.02929700
C	3.49017000	0.81256100	-2.39599100
C	2.10540900	0.83941800	-2.62335500
N	1.44861300	0.74326600	-1.46687600
H	4.51539400	0.66625100	-0.40455800
H	4.27843300	0.87889200	-3.13172200
H	1.54590400	0.96369600	-3.54399200
N	2.38956700	0.66312300	-0.49503300
C	0.50210900	0.65546300	0.93175300
C	1.90588000	0.62102900	0.82744800
C	0.01124900	0.64793200	2.23970600
C	2.77062300	0.54290000	1.91508600
C	0.84347300	0.57449300	3.35757900
H	-1.06137600	0.69512200	2.42072800
C	2.23238600	0.51430100	3.19290500
H	3.84843000	0.48547900	1.77460100
H	2.89923200	0.39405300	4.04554700
C	0.18958700	0.50432100	4.69259000
O	-0.93619600	0.11002300	4.86550700
O	0.93583700	0.90908800	5.74656600
H	-1.32602300	1.59237900	0.00618000
H	-0.69923100	2.01982900	-1.33502100
Ru	-0.54539000	0.48420900	-0.82944000

H	1.73813800	1.34177900	5.42971400
O	-0.44374900	2.06442300	-4.09385700
H	-0.43009200	3.02230800	-4.17039200
H	-0.57880900	1.89809300	-3.14269100



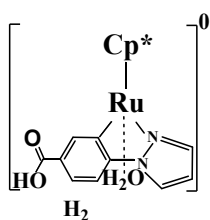
**Ru-7**

**52**

**E=-1207.427815(au)**

C	-1.01448600	-1.64091200	2.65339800
C	-1.56959300	-0.90691800	1.52767700
C	-2.72088300	-0.21632600	1.99001300
C	-1.88797000	-1.45596200	3.77511600
C	-2.90466900	-0.52712300	3.39427200
C	-1.07818400	-0.99865700	0.12155300
H	-1.48335500	-1.89539900	-0.36756400
H	-1.36581300	-0.12750200	-0.47515100
H	0.01435000	-1.07804800	0.08140300
C	0.18068500	-2.53317600	2.60095700
H	0.65350800	-2.61803400	3.58641000
H	-0.07682500	-3.54708400	2.26473300
H	0.93658300	-2.13794100	1.91137900
C	-1.77886200	-2.16414200	5.08139400
H	-2.24138300	-1.61048400	5.90515200
H	-2.28194000	-3.13828800	5.01709700
H	-0.73601800	-2.34730900	5.36043300
C	-4.05430500	-0.08711600	4.23875000
H	-4.38341600	0.92301900	3.97120800
H	-4.91716000	-0.75751700	4.12293500
H	-3.78721100	-0.07197100	5.30121600
C	-3.64694600	0.62239000	1.17183500
H	-3.14009700	1.06314900	0.30722200
H	-4.49430800	0.02670800	0.80568100
H	-4.06022700	1.44657100	1.76477400
C	3.25331600	0.81050600	3.06035700
C	3.13796100	0.97831400	1.69791000
C	1.75691200	0.99719400	1.44482800
N	1.07363800	0.84517700	2.57962900
H	4.12312500	0.74873400	3.69957400
H	3.94027400	1.08179800	0.98187300

H	1.21660300	1.14797700	0.51672200
N	1.99840800	0.73408400	3.56611700
C	0.09608400	0.57198100	4.97027000
C	1.49941900	0.61129900	4.88239000
C	-0.40960300	0.49186200	6.26883800
C	2.35441900	0.53463000	5.97764900
C	0.41118900	0.41460400	7.39626700
H	-1.48613000	0.47492500	6.43621500
C	1.80237300	0.42801200	7.24672200
H	3.43573300	0.54055400	5.85333400
H	2.46541100	0.30675800	8.10236300
H	-1.45464100	2.01050500	3.80915700
C	-0.25525500	0.26103700	8.71775200
O	-1.36503300	-0.18799200	8.85815200
O	0.45835100	0.65505600	9.79827700
O	-0.85460200	2.18328300	0.05524500
H	-0.97092500	1.75403100	0.92343800
H	-0.70398500	3.10860600	0.26954300
H	-1.21449300	2.19419400	2.98888800
H	1.24597100	1.13283100	9.51085900
Ru	-0.93871200	0.46920700	3.17989800



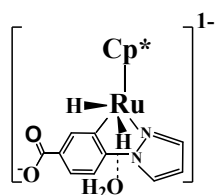
**Ru-8**

**52**

**E=-1207.412161 (au)**

C	-1.10791400	-1.87811400	2.34290000
C	-1.67199000	-1.02213900	1.31764300
C	-2.63326800	-0.19104000	1.95973400
C	-1.79251200	-1.61721100	3.58374600
C	-2.73481600	-0.55387200	3.35558400
C	-1.33924000	-1.05041900	-0.13642300
H	-1.99213600	-1.73779700	-0.69328000
H	-1.44153400	-0.05936800	-0.59508400
H	-0.30852700	-1.38434400	-0.30681100
C	-0.07894400	-2.93602100	2.12648800
H	0.53377800	-3.07997100	3.02377500
H	-0.54033300	-3.90159400	1.87635200
H	0.60100400	-2.67519100	1.30699300
C	-1.61068700	-2.37069700	4.85689900

H	-1.84902600	-1.75451400	5.73096700
H	-2.26194200	-3.25507300	4.88632100
H	-0.57582800	-2.71136600	4.97535800
C	-3.75590100	-0.04344300	4.31514000
H	-4.02265900	0.99726000	4.09795600
H	-4.68088600	-0.63655800	4.27283200
H	-3.39841300	-0.07792700	5.35125900
C	-3.41362300	0.90920500	1.32505300
H	-2.95048100	1.24695700	0.39145000
H	-4.44048400	0.59240300	1.09742600
H	-3.47441300	1.77746700	1.99239000
C	3.49094600	0.60058000	3.06977000
C	3.47835300	0.44666000	1.70014700
C	2.12574600	0.27070800	1.36887400
N	1.36141700	0.30869700	2.46169900
H	4.30986200	0.76326600	3.75650300
H	4.32895100	0.45500500	1.03405100
H	1.66665800	0.10726600	0.40114400
N	2.20782400	0.51963200	3.50074400
C	0.20652800	0.52470300	4.79191700
C	1.61348400	0.63798200	4.78527500
C	-0.37107300	0.68479300	6.05872900
C	2.40044800	0.83543200	5.91594700
C	0.37548700	0.90806200	7.21930900
H	-1.45442400	0.63514500	6.17425800
C	1.77179800	0.96775500	7.14633800
H	3.48685000	0.87300900	5.85515800
H	2.38392500	1.06598900	8.04211500
H	-2.75514400	2.95859100	5.14417600
C	-0.36500200	1.04167000	8.50414400
O	-1.48245200	0.62808700	8.68259000
O	0.28650100	1.67819000	9.50700300
O	-0.67148600	2.45210500	2.70343500
H	-0.49659800	2.70641500	3.62030300
H	0.15418100	2.61267800	2.22924800
H	-2.65170300	3.06687800	4.41370600
H	1.09499500	2.08046000	9.16757300
Ru	-0.71041800	0.12185800	2.96366200



**Ru-9'**

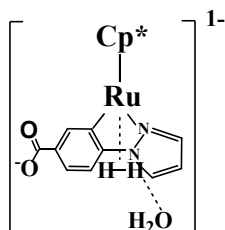
51

**E=-1206.96635 (au)**

C	-0.58647500	-1.73315000	-1.32924700
C	-1.29233300	-1.03147700	-2.37152000
C	-2.35724300	-0.29897100	-1.73703800
C	-1.22111200	-1.47296100	-0.08494500
C	-2.30032600	-0.55606500	-0.32061700
C	-1.08568800	-1.22135300	-3.83949400
H	-1.61036800	-2.11781500	-4.20242000
H	-1.44430400	-0.36562900	-4.42114000
H	-0.02390200	-1.34277300	-4.08502600
C	0.60679500	-2.61042100	-1.51089400
H	1.32655300	-2.47005200	-0.69444500
H	0.32834500	-3.67369500	-1.52423900
H	1.12778100	-2.39221900	-2.45009000
C	-0.83143900	-2.07702700	1.22283700
H	-1.21528700	-1.52092000	2.08610600
H	-1.20541500	-3.10899400	1.28489000
H	0.25956400	-2.11110400	1.33598600
C	-3.31774900	-0.11315800	0.68059000
H	-3.62740800	0.92210200	0.49786500
H	-4.21610200	-0.74489100	0.62331200
H	-2.94196800	-0.16592200	1.70878200
C	-3.43410700	0.47317300	-2.42606600
H	-3.09089600	0.86707000	-3.38948300
H	-4.31841800	-0.15361300	-2.61277500
H	-3.75206500	1.32715500	-1.81796600
C	3.70698700	0.70255800	-0.87102600
C	3.67499200	0.69652300	-2.25478400
C	2.31663800	0.72208500	-2.59129200
N	1.56843100	0.74087100	-1.48151300
H	4.53059400	0.70016300	-0.17047100
H	4.52143900	0.68784700	-2.92685000
H	1.82846000	0.76547000	-3.55919700
N	2.42788200	0.72910600	-0.43770200
C	0.44119300	0.85422600	0.83444400
C	1.83787200	0.75423800	0.84937500
C	-0.18557100	0.85605000	2.07664000
C	2.58472000	0.64393800	2.02410900
C	0.50879000	0.66171600	3.26655900
H	-1.26781800	0.92186500	2.16157600
C	1.90448400	0.58927900	3.23401400
H	3.67285800	0.56968600	1.98808500
H	2.41888500	0.46599900	4.18523300



C	-0.28125300	0.39861600	4.56676800
O	-1.49258000	0.12741200	4.38241400
O	0.38649200	0.44733400	5.61828300
H	-0.99124700	1.92933700	-0.38625900
H	-0.63329100	1.82874200	-1.95836400
Ru	-0.47947900	0.54651400	-0.99497700
O	-0.07269500	1.71795700	-4.53363000
H	-0.31784700	1.44362900	-3.62973900
H	0.24756200	2.61397300	-4.39312300



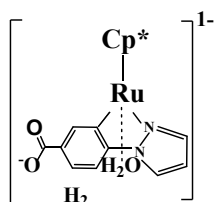
**Ru-9**

**51**

**E=-1206.970263(au)**

C	-0.98604500	-1.61234300	2.58089700
C	-1.64065200	-0.88643300	1.50475700
C	-2.75490800	-0.20962900	2.07804700
C	-1.75516100	-1.44700600	3.77498100
C	-2.81771200	-0.53291100	3.48900200
C	-1.28142200	-1.00575300	0.05970800
H	-1.64123700	-1.95884600	-0.35719900
H	-1.70805300	-0.19658000	-0.54195700
H	-0.19468600	-0.97899600	-0.08871600
C	0.21915700	-2.47829200	2.42512600
H	0.75590300	-2.57709900	3.37575700
H	-0.04417500	-3.48950700	2.08171000
H	0.92124100	-2.05416000	1.69641200
C	-1.50741400	-2.13458200	5.07472700
H	-1.85612600	-1.55802200	5.93867000
H	-2.01922400	-3.10726400	5.08364300
H	-0.43896100	-2.31462700	5.23876300
C	-3.90756800	-0.12923600	4.42620300
H	-4.26604500	0.88310900	4.20612800
H	-4.77007700	-0.80840500	4.35423000
H	-3.56817900	-0.13593900	5.46800600
C	-3.76937700	0.61841900	1.35971600
H	-3.38785700	0.99557100	0.40467900
H	-4.68073900	0.03760800	1.15548000
H	-4.06466600	1.48727400	1.95997900
C	3.28316900	0.77107100	3.12563200

C	3.22759200	0.87888200	1.74674800
C	1.86245700	0.91719700	1.44044500
N	1.13271600	0.83676300	2.55989900
H	4.12064400	0.71732000	3.80752400
H	4.06160100	0.93029900	1.06111600
H	1.35546300	1.03173500	0.48871000
N	2.01313600	0.74961100	3.58335800
C	0.05779200	0.69338100	4.91845800
C	1.45751200	0.67332000	4.88953400
C	-0.52366600	0.63213400	6.18379800
C	2.25038400	0.57236700	6.03419200
C	0.22143300	0.47087700	7.34937100
H	-1.60581700	0.64601000	6.31415000
C	1.61679100	0.46272300	7.26533400
H	3.33946300	0.56300600	5.96289000
H	2.16854000	0.35850000	8.19753800
H	-1.35326100	2.08676400	3.67684500
C	-0.49943300	0.22351800	8.69514900
O	-1.72925200	0.01030300	8.59171000
O	0.23885200	0.24067700	9.70132000
O	-0.69390500	2.14998600	-0.02877100
H	-0.87038500	1.60364400	0.76393500
H	-0.30465500	2.94186600	0.35512200
H	-1.16125100	2.22642800	2.82802500
Ru	-0.90930000	0.51829600	3.09242100



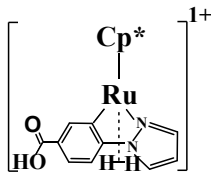
**Ru-10**

**51**

**E=-1206.95206(au)**

C	-1.11345800	-1.94399000	2.31406900
C	-1.61973100	-1.10473400	1.23939800
C	-2.58148100	-0.23041300	1.80719600
C	-1.85367000	-1.63409500	3.51503200
C	-2.74447800	-0.54738900	3.21654600
C	-1.20553500	-1.18058500	-0.19138100
H	-1.79255300	-1.92284200	-0.75428400
H	-1.32516400	-0.21443100	-0.69741000
H	-0.15103100	-1.47043100	-0.28882200

C	-0.11208100	-3.03891500	2.15832100
H	0.42440600	-3.21211700	3.09817500
H	-0.57873500	-3.98820300	1.85366900
H	0.64187600	-2.78540200	1.40229900
C	-1.74882300	-2.34377500	4.82155100
H	-1.88097400	-1.65489100	5.66323600
H	-2.50831300	-3.13452300	4.90629800
H	-0.76280100	-2.80563600	4.94476200
C	-3.74140900	0.07114000	4.13891400
H	-3.87867200	1.13831000	3.92003400
H	-4.73001700	-0.40764000	4.06316000
H	-3.42106100	0.00483000	5.18548400
C	-3.31234100	0.86328800	1.10458100
H	-2.80109900	1.15596700	0.18009000
H	-4.33963000	0.56681900	0.84611600
H	-3.37729400	1.75817500	1.73539200
C	3.49808900	0.55656000	2.94975300
C	3.46801500	0.39587100	1.57503000
C	2.11215600	0.23740800	1.26347700
N	1.36415400	0.29355400	2.37023300
H	4.32135100	0.70915200	3.63398900
H	4.31133900	0.39084100	0.89882700
H	1.63055000	0.08024200	0.30531000
N	2.22424600	0.49519200	3.39513700
C	0.25365900	0.40592600	4.72721500
C	1.63993800	0.63505900	4.69062300
C	-0.34601700	0.65890500	5.96840800
C	2.40115400	1.02578400	5.79234600
C	0.36193000	1.09176200	7.09118900
H	-1.42403200	0.54955500	6.10459200
C	1.74789600	1.24401900	6.99830300
H	3.47844600	1.18169600	5.70704200
H	2.27247800	1.55892200	7.89821200
H	-2.43754000	2.56823000	6.62549400
C	-0.37413200	1.43666000	8.40383200
O	-1.62690800	1.44927300	8.31814300
O	0.36331800	1.67513900	9.38002200
O	-0.81753200	2.40785400	3.05298800
H	-1.12005300	2.38256800	3.97576200
H	0.11597700	2.64422400	3.13327100
H	-2.72968200	2.89522700	6.00684300
Ru	-0.69357700	0.04868500	2.90734900



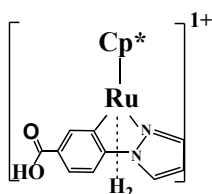
**Ru-11**

**49**

**E=-1130.971358(au)**

C	-1.06611400	-1.99252200	-2.19527600
C	-1.40749100	-0.61341000	-2.37199200
C	-2.14414000	-0.16412800	-1.19754300
C	-1.50342700	-2.36476000	-0.88256900
C	-2.21804000	-1.25852300	-0.28156700
C	-1.13347700	0.21106200	-3.58193700
H	-1.91509200	0.07701700	-4.34298100
H	-1.09032900	1.27633800	-3.33233100
H	-0.17240900	-0.05359800	-4.04010400
C	-0.36691400	-2.87214500	-3.17656600
H	0.34410100	-3.54562500	-2.68196300
H	-1.07223000	-3.49902500	-3.73986000
H	0.19460400	-2.28285500	-3.91140000
C	-1.30869900	-3.69518500	-0.24270400
H	-1.21964300	-3.59815900	0.84506100
H	-2.15696200	-4.36325700	-0.44926000
H	-0.39974100	-4.18582700	-0.60814500
C	-2.92974500	-1.30091200	1.02731600
H	-3.13780200	-0.29483500	1.40785200
H	-3.89289400	-1.82363700	0.94501800
H	-2.33504700	-1.81704500	1.79068000
C	-2.73799700	1.19189500	-1.02780100
H	-2.05626900	1.96732100	-1.39808800
H	-3.68684200	1.28638900	-1.57382100
H	-2.93510800	1.41310300	0.02637100
C	3.82739400	0.60895800	-0.59638500
C	4.03548400	-0.17313800	-1.71611900
C	2.79864100	-0.78294700	-1.95781500
N	1.89826300	-0.40355300	-1.05210100
H	4.49993400	1.25914800	-0.05398500
H	4.95306700	-0.28260700	-2.27532000
H	2.50614000	-1.47404100	-2.73875200
N	2.54237800	0.44802200	-0.21670900
C	0.42284200	0.63517100	0.87683100
C	1.77867100	1.01362700	0.84768400
C	-0.30916100	1.18951000	1.93108200

C	2.38379000	1.86400700	1.76615700
C	0.24526000	2.07322100	2.86282200
H	-1.36323600	0.94136100	2.05566800
C	1.60161300	2.40163100	2.77971000
H	3.44444500	2.10339900	1.71769600
H	2.07698200	3.03413800	3.52865800
C	-0.64383600	2.60583600	3.93211500
O	-1.66248600	2.07045500	4.28724600
O	-0.25398900	3.76737000	4.51016600
H	1.37127200	2.25473700	-2.72754600
H	1.23853600	2.12780300	-2.00364400
Ru	-0.16568500	-0.69784900	-0.63948500
H	0.47717000	4.15258200	4.01251200



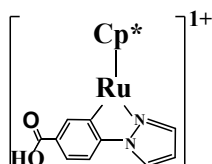
**Ru-12**

**49**

**E=-1130.97152(au)**

C	-1.06807300	-1.99046900	-2.19879800
C	-1.40290900	-0.60631500	-2.35743100
C	-2.14393000	-0.17094200	-1.18043300
C	-1.51001600	-2.37802200	-0.89293000
C	-2.22142700	-1.27653100	-0.27848400
C	-1.11554200	0.23588300	-3.55198000
H	-1.90507500	0.14038500	-4.31065300
H	-1.03989400	1.29394400	-3.27919600
H	-0.16496700	-0.04603200	-4.02156400
C	-0.36980700	-2.85969400	-3.19006900
H	0.33832100	-3.54175400	-2.70309600
H	-1.07599700	-3.47711200	-3.76262100
H	0.19465100	-2.26288700	-3.91653500
C	-1.32121500	-3.71654100	-0.26825600
H	-1.22079600	-3.63073800	0.81953300
H	-2.17775500	-4.37464400	-0.47252200
H	-0.42061200	-4.21224000	-0.64724500
C	-2.93349300	-1.33352800	1.02969200
H	-3.13675400	-0.33174300	1.42380800
H	-3.89868900	-1.85150500	0.94124500
H	-2.34014300	-1.86189700	1.78571700
C	-2.74010800	1.18240600	-0.99787400
H	-2.05769800	1.96352700	-1.35444800

H	-3.68549100	1.28149000	-1.54903100
H	-2.94542200	1.39115500	0.05725400
C	3.82339800	0.59961900	-0.60187900
C	4.03379800	-0.20123000	-1.70767100
C	2.79755600	-0.81577300	-1.94141600
N	1.89548700	-0.42153900	-1.04375400
H	4.49458400	1.25929100	-0.06939700
H	4.95245600	-0.31979700	-2.26326800
H	2.50723900	-1.52103000	-2.71037200
N	2.53744000	0.44463300	-0.22231500
C	0.42054500	0.63355300	0.87508300
C	1.77341000	1.02193600	0.83506900
C	-0.30997000	1.19345300	1.92744200
C	2.37559200	1.89039500	1.73844700
C	0.24194100	2.09296500	2.84549000
H	-1.36078900	0.93689000	2.06202200
C	1.59438600	2.43387400	2.74960900
H	3.43364800	2.13901300	1.68020800
H	2.06798000	3.08098000	3.48713600
C	-0.64563100	2.62971000	3.91399400
O	-1.65671000	2.08873000	4.28204900
O	-0.26368400	3.80200300	4.47536700
H	1.42965600	2.14951500	-2.66833800
H	1.30846000	2.24904100	-1.93856400
Ru	-0.16698000	-0.71541600	-0.62674300
H	0.46097400	4.18785100	3.96877200



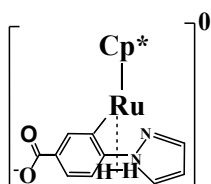
**Ru-13**

47

**E=-1129.79855(au)**

C	-1.06882100	-1.90796500	-2.25582800
C	-1.56077900	-0.57905300	-2.43112900
C	-2.26509400	-0.17502100	-1.22265600
C	-1.37903200	-2.29403500	-0.90848000
C	-2.16419200	-1.24435900	-0.28516900
C	-1.43840500	0.24708300	-3.66422100
H	-2.29911900	0.09828400	-4.33171300
H	-1.38717700	1.31481000	-3.42397500
H	-0.53238400	-0.00661900	-4.22673200
C	-0.33968800	-2.72881500	-3.26542400

H	0.38679200	-3.39921000	-2.78932100
H	-1.02258000	-3.35657600	-3.85459900
H	0.20956700	-2.09682000	-3.97460200
C	-1.03898300	-3.59483100	-0.26935300
H	-0.92399100	-3.48269200	0.81432000
H	-1.82627000	-4.34194300	-0.44535300
H	-0.09965900	-4.00081800	-0.66163000
C	-2.76692000	-1.32054600	1.07582600
H	-3.06474100	-0.33284400	1.44408300
H	-3.66212800	-1.95765900	1.08209600
H	-2.05650500	-1.73318300	1.80208900
C	-2.99292300	1.11326200	-1.04661000
H	-2.43631200	1.94698600	-1.49030500
H	-3.98350300	1.08253800	-1.52160600
H	-3.13937600	1.35124000	0.01201600
C	3.89478700	0.33867300	-0.38605700
C	4.10950000	-0.44499400	-1.50370300
C	2.83605600	-0.89675500	-1.86896200
N	1.90865800	-0.42562100	-1.03644700
H	4.58826200	0.89231300	0.23200800
H	5.05437900	-0.65568900	-1.98271800
H	2.53546300	-1.53758000	-2.68863600
N	2.57095800	0.33304000	-0.12853800
C	0.40725300	0.72080700	0.82107800
C	1.79207900	0.96194200	0.88909300
C	-0.33689300	1.34154900	1.82776700
C	2.41471300	1.73566500	1.86214700
C	0.23684400	2.15312400	2.81217200
H	-1.41727000	1.20566900	1.87279800
C	1.62243600	2.33790300	2.83028800
H	3.49484700	1.86720000	1.88887800
H	2.10669700	2.90600100	3.62387000
C	-0.66664500	2.76267300	3.82685300
O	-1.76080000	2.33614500	4.09440900
O	-0.19746800	3.86422100	4.46053900
Ru	-0.20121400	-0.52157600	-0.76688000
H	0.60555600	4.17605300	4.02638400



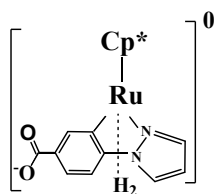
**Ru-14**

**E=-1130.53097(au)**

C	-0.58658600	-1.84622200	-1.35348600
C	-1.25344100	-1.16329700	-2.44352900
C	-2.31401600	-0.40288800	-1.86133500
C	-1.28381800	-1.56570900	-0.13695600
C	-2.33979200	-0.64138100	-0.43487200
C	-0.94726800	-1.32465000	-3.89544900
H	-1.46030400	-2.19491500	-4.33446500
H	-1.24949400	-0.43977300	-4.46867400
H	0.12750400	-1.46828400	-4.06417400
C	0.59422300	-2.74787100	-1.49458800
H	1.16484000	-2.79816700	-0.55967900
H	0.29662100	-3.77238400	-1.76114500
H	1.27992900	-2.38816900	-2.27205700
C	-0.97608600	-2.15181000	1.20074200
H	-1.32066900	-1.52201500	2.02914800
H	-1.44912400	-3.13893800	1.30127800
H	0.10353600	-2.27963400	1.34393400
C	-3.38344000	-0.15473100	0.51626600
H	-3.69411200	0.86896500	0.27628400
H	-4.28175500	-0.78967100	0.48629000
H	-3.02088200	-0.14597900	1.55089100
C	-3.30677800	0.43711400	-2.59528400
H	-2.90005500	0.80619700	-3.54427700
H	-4.22358500	-0.12777000	-2.81867700
H	-3.59747800	1.31129900	-2.00084300
C	3.75551600	0.66141300	-0.83339200
C	3.74941300	0.55028400	-2.21383500
C	2.39588800	0.46671500	-2.56122800
N	1.62897000	0.52078100	-1.46781700
H	4.56666100	0.76055400	-0.12534400
H	4.60654600	0.53794600	-2.87226200
H	1.92725200	0.37478200	-3.53385000
N	2.47071900	0.63957500	-0.41773200
C	0.46269200	0.73841400	0.83391600
C	1.86336600	0.72191100	0.86600400
C	-0.16732700	0.80288300	2.07582900
C	2.61089700	0.74392400	2.04498500
C	0.53026300	0.75979600	3.28026700
H	-1.25311100	0.82016400	2.15866300
C	1.92840600	0.75593900	3.25465200
H	3.70206300	0.72600900	2.01808700
H	2.44335500	0.74482800	4.21344600
C	-0.24779900	0.62047800	4.60859500



O	-1.46555700	0.35929200	4.46925700
O	0.43778600	0.75490100	5.64284100
H	-0.72711100	2.01848500	-0.78773300
H	-0.57096100	1.92158900	-1.65094100
Ru	-0.42830600	0.31787200	-0.99236300



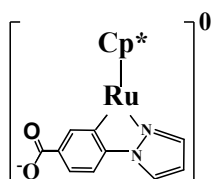
**Ru-15**

**48**

**E=-1130.514631(au)**

C	-0.93547100	-2.51686000	-1.19901600
C	-1.15371900	-1.55355600	-2.23206500
C	-1.84429700	-0.44785200	-1.62930400
C	-1.60124500	-2.07759400	0.01591500
C	-2.16552100	-0.79336800	-0.24882800
C	-0.68957400	-1.64517500	-3.64699500
H	-1.39024400	-2.20663800	-4.28342200
H	-0.57943300	-0.64797800	-4.09259900
H	0.28676500	-2.14300800	-3.71944800
C	-0.21194300	-3.81187700	-1.34147600
H	0.32363300	-4.06231600	-0.41849400
H	-0.90404300	-4.63959100	-1.55907900
H	0.52743400	-3.77082700	-2.14994700
C	-1.68707500	-2.86400400	1.27948900
H	-0.72110400	-3.32217800	1.52438800
H	-1.95741400	-2.23180400	2.13153500
H	-2.43395600	-3.66869800	1.20654900
C	-2.95142000	0.05103100	0.69494500
H	-2.72988000	1.11456600	0.54609600
H	-4.03388100	-0.09355300	0.56438300
H	-2.70062500	-0.17292800	1.73726300
C	-2.23522100	0.81513500	-2.31750800
H	-1.47207300	1.11499600	-3.04738800
H	-3.19431300	0.71693500	-2.84809900
H	-2.32968700	1.63745800	-1.59980600
C	3.36017400	1.73503900	-0.81474800
C	3.35801500	1.48070200	-2.17881400
C	2.27383800	0.62145800	-2.37283700
N	1.66051600	0.36809200	-1.21352600
H	4.00999200	2.35011700	-0.20740200
H	4.04581100	1.86722900	-2.91725200

H	1.89350300	0.16910100	-3.28109500
N	2.33878100	1.05358900	-0.26735900
C	0.68259100	0.18999600	1.23772500
C	1.84886200	0.96146400	1.07902200
C	0.20901000	0.11128400	2.55466700
C	2.50677800	1.61286200	2.11701100
C	0.82710400	0.74642000	3.63344400
H	-0.68518300	-0.46172800	2.80456000
C	1.97948800	1.49677100	3.39907000
H	3.41097100	2.19856300	1.94134100
H	2.43303400	1.97842500	4.26361800
C	0.24786600	0.63703000	5.06525200
O	-0.79175000	-0.04962300	5.16130000
O	0.89623100	1.25378800	5.93759100
H	0.35306100	2.89843900	-0.67251000
H	0.43803400	3.23277300	-1.33498000
Ru	-0.05789900	-0.67470100	-0.50593900



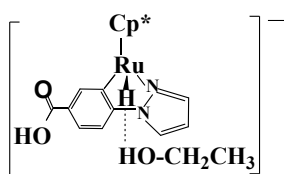
**Ru-16**

**46**

**E=-1129.342256(au)**

C	-2.05781900	-1.07620500	-1.64984300
C	-2.93338300	-0.89017000	-0.51021900
C	-2.39307600	-1.64218200	0.57070200
C	-1.00571400	-1.97634900	-1.26414200
C	-1.19565000	-2.31330200	0.12490800
C	-4.19134800	-0.08645800	-0.49341900
H	-5.08023000	-0.68628900	-0.74633600
H	-4.36355200	0.36051500	0.49414600
H	-4.14704600	0.73749800	-1.21874600
C	-2.27915200	-0.49946200	-3.00831500
H	-1.34470000	-0.46980400	-3.58080200
H	-3.01266400	-1.07777900	-3.59211000
H	-2.65014600	0.53261400	-2.94679800
C	0.05584600	-2.53249300	-2.15255300
H	0.98524100	-2.71601700	-1.59979300
H	-0.25223900	-3.48689100	-2.60557500
H	0.30433600	-1.83814000	-2.96445500
C	-0.42906900	-3.31412900	0.92153500

H	-0.39499900	-3.02826100	1.97929000
H	-0.87397000	-4.32052000	0.85865800
H	0.60911000	-3.39675900	0.57589300
C	-2.94141000	-1.73727200	1.95478200
H	-2.28785800	-1.23985400	2.69500000
H	-3.92720500	-1.26197000	2.02327300
H	-3.05907400	-2.78931300	2.25114900
C	-0.98212000	4.09604300	-0.87262600
C	-1.65752400	2.87976300	-0.67654500
H	-1.41301300	5.07933900	-1.00086000
H	-2.71831900	2.67247000	-0.59883700
N	0.44439700	2.42701200	-0.67040300
C	1.15469700	0.20929300	-0.21512700
C	1.53372500	1.54258600	-0.51392300
C	2.25205900	-0.65758500	-0.05464700
C	2.84250000	1.99424400	-0.64815700
C	3.58052800	-0.24530500	-0.16642400
H	2.07811500	-1.70361400	0.20210700
C	3.88226700	1.09353900	-0.46778600
H	3.05861200	3.03195900	-0.90211500
H	4.90945300	1.41895800	-0.63122800
H	1.06847500	-1.31050800	2.71399700
C	4.65407200	-1.24758900	0.03563000
O	4.55571500	-2.43193400	-0.17139200
O	5.83487900	-0.74605500	0.49831400
C	0.05418100	2.10167600	2.77705900
H	-0.10594000	2.74114600	3.65616400
H	1.01461400	1.58648400	2.89967000
H	0.09813100	2.73620700	1.88158100
C	-1.07943100	1.07795500	2.70777500
H	-0.66924900	0.42472700	1.58486700
H	-2.00631400	1.53398600	2.26006300
O	-1.21047000	0.26702700	3.67195800
H	0.62316100	-0.97386600	3.21741600
C	0.35780300	3.77098000	-0.85813000
N	-0.78854200	1.87310200	-0.55705500
H	1.24259100	4.38461400	-0.95498000
Ru	-0.85756300	-0.16386900	-0.07623600
H	5.68360000	0.17075500	0.76172400



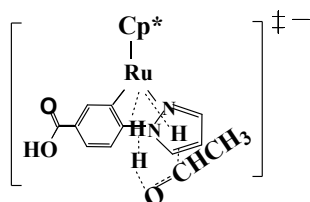
**Ru-17**

57

**E=-1285.51041(au)**

C	1.62179400	-1.70704600	1.51354700
C	2.51519000	-1.54587300	0.38504000
C	1.85844900	-2.08624500	-0.75838500
C	0.43307200	-2.35655900	1.05562000
C	0.56358900	-2.58248400	-0.36460900
C	3.89720400	-0.97856200	0.42919400
H	4.67292200	-1.75865000	0.49948500
H	4.10410400	-0.37437000	-0.46416000
H	4.02460500	-0.32615100	1.30428500
C	1.92683600	-1.28572400	2.91213700
H	1.02203000	-1.29395400	3.53123200
H	2.66861600	-1.94106800	3.39520900
H	2.32554000	-0.26164600	2.94524800
C	-0.73389500	-2.77884400	1.88523200
H	-1.68159600	-2.58844500	1.36518200
H	-0.70018000	-3.85163200	2.13020200
H	-0.77315600	-2.22043800	2.82846500
C	-0.36978200	-3.36870100	-1.22306100
H	-0.40145100	-2.96662600	-2.24320300
H	-0.08348900	-4.43132900	-1.29099000
H	-1.39446000	-3.33472900	-0.83216500
C	2.44409400	-2.22195700	-2.12584500
H	1.67076900	-2.11783000	-2.89601500
H	3.19918500	-1.45306500	-2.32025200
H	2.91630600	-3.20822200	-2.25762200
C	1.37232100	3.51270200	1.62701300
C	1.84549000	2.24957400	1.23167800
H	1.94591300	4.33328200	2.03595400
H	2.85150500	1.84690900	1.23787100
N	-0.27473900	2.26310100	0.85895300
C	-1.31179100	0.28695600	0.06167600
C	-1.47726700	1.63251100	0.49123400
C	-2.52811900	-0.34076000	-0.27557000
C	-2.69422200	2.30001300	0.58102900
C	-3.76881700	0.29475100	-0.20587500
H	-2.51610300	-1.36782300	-0.64342300
C	-3.85672300	1.63077300	0.22640900
H	-2.74605300	3.32916100	0.93744900
H	-4.82056400	2.12143900	0.36232700
H	0.46220700	0.24592900	-1.51606400
C	-4.97710500	-0.46274900	-0.60704100

O	-5.10357900	-1.66246200	-0.56913000
O	-6.01297800	0.30052400	-1.06334900
C	1.85277200	3.15940300	-2.23698900
H	1.54390900	3.07697800	-3.28590300
H	1.03391000	2.77170000	-1.61715200
H	1.99961400	4.21971200	-1.99176500
C	3.11689900	2.35739500	-1.99134700
H	3.44185100	2.51176600	-0.94400100
H	3.93333500	2.73300900	-2.62776000
O	2.96540300	0.99655400	-2.28528700
H	2.18040900	0.66206000	-1.78993200
C	0.01815500	3.49118900	1.37525900
N	0.84370400	1.49543500	0.75957500
H	-0.74977400	4.23778100	1.52220300
Ru	0.59755200	-0.41775200	-0.00240700
H	-5.68460700	1.20210200	-1.17443900



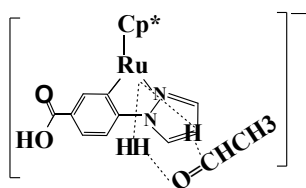
**Ru-TS<sub>17-18</sub>**

**57 -361.90i cm<sup>-1</sup>**

**E=-1285.4653164(au)**

C	-1.70771700	-1.29442800	-1.69208500
C	-2.71959600	-1.15863900	-0.66162700
C	-2.24420800	-1.83632800	0.49514000
C	-0.64379400	-2.12643800	-1.16959000
C	-0.96286900	-2.44061500	0.19850400
C	-4.01989700	-0.43464000	-0.77438000
H	-4.85468800	-1.10701700	-1.02774500
H	-4.27199100	0.06698700	0.16875600
H	-3.98332900	0.33672800	-1.55540400
C	-1.81666300	-0.79152400	-3.09226800
H	-0.82429100	-0.62003100	-3.52560000
H	-2.35267300	-1.49803600	-3.74481600
H	-2.35302100	0.16489900	-3.13202400
C	0.52465700	-2.64236300	-1.93901500
H	1.40096400	-2.78526800	-1.29560000
H	0.29952400	-3.60939700	-2.41305900
H	0.82390000	-1.94207100	-2.72807700
C	-0.19874900	-3.32957400	1.12069100
H	-0.24312900	-2.95419300	2.14953100

H	-0.58783500	-4.36006000	1.11875700
H	0.86055100	-3.38043100	0.84027900
C	-2.94575100	-1.90710700	1.81332100
H	-2.56697000	-1.15690600	2.53551100
H	-4.02191100	-1.73513400	1.68660000
H	-2.82097200	-2.90129700	2.26252500
C	-1.11378900	3.88934300	-1.26007200
C	-1.71561700	2.64882600	-0.99467800
H	-1.60034500	4.82063900	-1.51403700
H	-2.76325000	2.37238200	-0.96491400
N	0.40266600	2.36286800	-0.78260900
C	1.24451200	0.24433100	-0.11870200
C	1.54033700	1.57618800	-0.48892800
C	2.38193600	-0.52686300	0.17276900
C	2.82130500	2.11416300	-0.57895200
C	3.68356200	-0.02738300	0.10688100
H	2.26163000	-1.56226300	0.49612600
C	3.90656000	1.30580800	-0.27513900
H	2.98119400	3.14523600	-0.89336700
H	4.91652700	1.69544300	-0.40160000
H	-0.07015600	-0.45710400	2.11889200
C	4.80926800	-0.93438400	0.43541000
O	4.79869400	-2.13417300	0.31078400
O	5.92826700	-0.32191500	0.91588300
C	-1.35907500	2.74435200	2.59967700
H	-1.68855700	3.26081900	3.51159900
H	-0.27085100	2.60279900	2.67316600
H	-1.57228300	3.38831400	1.73117800
C	-2.02586700	1.36829000	2.48556900
H	-1.62355700	0.94558300	1.48270500
H	-3.11997100	1.50558400	2.24352900
O	-1.77596000	0.54612800	3.49266900
H	-0.53236800	-0.22339900	2.75709500
C	0.23969600	3.67063000	-1.11083900
N	-0.79235200	1.73054000	-0.70847800
H	1.08473300	4.33815800	-1.20552900
Ru	-0.75368300	-0.29529100	-0.07795600
H	5.70552200	0.59777700	1.10835500



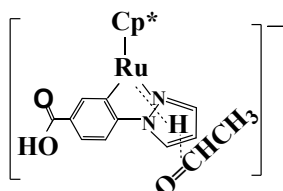
**Ru-18**

57

**E=-1285.4717936(au)**

C	-2.05781900	-1.07620500	-1.64984300
C	-2.93338300	-0.89017000	-0.51021900
C	-2.39307600	-1.64218200	0.57070200
C	-1.00571400	-1.97634900	-1.26414200
C	-1.19565000	-2.31330200	0.12490800
C	-4.19134800	-0.08645800	-0.49341900
H	-5.08023000	-0.68628900	-0.74633600
H	-4.36355200	0.36051500	0.49414600
H	-4.14704600	0.73749800	-1.21874600
C	-2.27915200	-0.49946200	-3.00831500
H	-1.34470000	-0.46980400	-3.58080200
H	-3.01266400	-1.07777900	-3.59211000
H	-2.65014600	0.53261400	-2.94679800
C	0.05584600	-2.53249300	-2.15255300
H	0.98524100	-2.71601700	-1.59979300
H	-0.25223900	-3.48689100	-2.60557500
H	0.30433600	-1.83814000	-2.96445500
C	-0.42906900	-3.31412900	0.92153500
H	-0.39499900	-3.02826100	1.97929000
H	-0.87397000	-4.32052000	0.85865800
H	0.60911000	-3.39675900	0.57589300
C	-2.94141000	-1.73727200	1.95478200
H	-2.28785800	-1.23985400	2.69500000
H	-3.92720500	-1.26197000	2.02327300
H	-3.05907400	-2.78931300	2.25114900
C	-0.98212000	4.09604300	-0.87262600
C	-1.65752400	2.87976300	-0.67654500
H	-1.41301300	5.07933900	-1.00086000
H	-2.71831900	2.67247000	-0.59883700
N	0.44439700	2.42701200	-0.67040300
C	1.15469700	0.20929300	-0.21512700
C	1.53372500	1.54258600	-0.51392300
C	2.25205900	-0.65758500	-0.05464700
C	2.84250000	1.99424400	-0.64815700
C	3.58052800	-0.24530500	-0.16642400
H	2.07811500	-1.70361400	0.20210700
C	3.88226700	1.09353900	-0.46778600
H	3.05861200	3.03195900	-0.90211500
H	4.90945300	1.41895800	-0.63122800
H	1.06847500	-1.31050800	2.71399700
C	4.65407200	-1.24758900	0.03563000
O	4.55571500	-2.43193400	-0.17139200

O	5.83487900	-0.74605500	0.49831400
C	0.05418100	2.10167600	2.77705900
H	-0.10594000	2.74114600	3.65616400
H	1.01461400	1.58648400	2.89967000
H	0.09813100	2.73620700	1.88158100
C	-1.07943100	1.07795500	2.70777500
H	-0.66924900	0.42472700	1.58486700
H	-2.00631400	1.53398600	2.26006300
O	-1.21047000	0.26702700	3.67195800
H	0.62316100	-0.97386600	3.21741600
C	0.35780300	3.77098000	-0.85813000
N	-0.78854200	1.87310200	-0.55705500
H	1.24259100	4.38461400	-0.95498000
Ru	-0.85756300	-0.16386900	-0.07623600
H	5.68360000	0.17075500	0.76172400



**Ru-19**

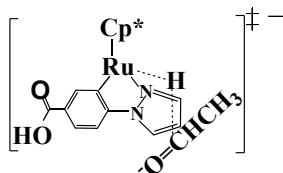
**55**

**E=-1284.2974388(au)**

C	-2.37113000	-0.58524000	-1.59495300
C	-3.08478000	-0.66410400	-0.33648200
C	-2.41702500	-1.62469600	0.47376800
C	-1.29250200	-1.53219400	-1.55650600
C	-1.30075600	-2.17023700	-0.26365000
C	-4.33916700	0.07267900	-0.00395900
H	-5.24270900	-0.46696400	-0.33188500
H	-4.43090300	0.24066400	1.07649000
H	-4.36525200	1.05740100	-0.48958400
C	-2.76535900	0.27692500	-2.74756000
H	-1.92673300	0.41925600	-3.43922100
H	-3.60496700	-0.14666600	-3.32214400
H	-3.07342600	1.27562800	-2.40802100
C	-0.35630500	-1.84898100	-2.67427700
H	0.64733100	-2.08703800	-2.30204800
H	-0.70294900	-2.71011400	-3.26526200
H	-0.24541700	-0.99558400	-3.35440500
C	-0.41628800	-3.26811700	0.22581400
H	-0.05636900	-3.04481500	1.24050700
H	-0.93923600	-4.23771900	0.25094700
H	0.46095600	-3.39161600	-0.42128100



C	-2.79029000	-2.05683300	1.85252400
H	-1.89063600	-2.20678800	2.46721200
H	-3.42367100	-1.31125200	2.34989300
H	-3.34752300	-3.00611000	1.82934100
C	-1.01577900	4.30901100	0.11793000
C	-1.70672400	3.08614100	0.15765900
H	-1.42741200	5.30510800	0.20615000
H	-2.76246300	2.88704900	0.29487100
N	0.37103500	2.61180800	-0.11696600
C	1.03943300	0.34208700	-0.27635800
C	1.43951300	1.70250700	-0.26332600
C	2.11466500	-0.55954500	-0.39308700
C	2.75305200	2.14953500	-0.35567400
C	3.44756900	-0.15331000	-0.47865500
H	1.91926600	-1.63261500	-0.37572400
C	3.77282000	1.21377000	-0.46153300
H	2.98988300	3.21365500	-0.34941100
H	4.79997900	1.55236300	-0.59642700
C	4.50249300	-1.18931500	-0.59061100
O	4.36447200	-2.28160900	-1.08273700
O	5.71780200	-0.83453100	-0.08163700
C	1.11844500	0.56325000	3.14496300
H	1.53426200	0.50089300	4.16122700
H	1.91542500	0.32386900	2.43137100
H	0.76757500	1.58826400	2.96633400
C	-0.01319200	-0.44373300	3.02174900
H	-0.44563000	-0.00051900	1.64404200
H	-0.98199500	-0.05649500	3.43499800
O	0.22241500	-1.66746700	3.07219300
C	0.30899800	3.96982200	-0.05478100
N	-0.86271200	2.06011800	0.01419000
H	1.19888300	4.57886500	-0.13326000
Ru	-0.94840900	-0.03654800	-0.00401200
H	5.60181700	-0.01176500	0.41075800



**Ru-TS<sub>19-20</sub>**

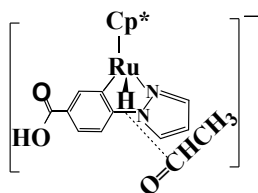
**55 -81.02i cm<sup>-1</sup>**

**E=-1284.2923062(au)**

C	-2.37113000	-0.58524000	-1.59495300
C	-3.08478000	-0.66410400	-0.33648200

C	-2.41702500	-1.62469600	0.47376800
C	-1.29250200	-1.53219400	-1.55650600
C	-1.30075600	-2.17023700	-0.26365000
C	-4.33916700	0.07267900	-0.00395900
H	-5.24270900	-0.46696400	-0.33188500
H	-4.43090300	0.24066400	1.07649000
H	-4.36525200	1.05740100	-0.48958400
C	-2.76535900	0.27692500	-2.74756000
H	-1.92673300	0.41925600	-3.43922100
H	-3.60496700	-0.14666600	-3.32214400
H	-3.07342600	1.27562800	-2.40802100
C	-0.35630500	-1.84898100	-2.67427700
H	0.64733100	-2.08703800	-2.30204800
H	-0.70294900	-2.71011400	-3.26526200
H	-0.24541700	-0.99558400	-3.35440500
C	-0.41628800	-3.26811700	0.22581400
H	-0.05636900	-3.04481500	1.24050700
H	-0.93923600	-4.23771900	0.25094700
H	0.46095600	-3.39161600	-0.42128100
C	-2.79029000	-2.05683300	1.85252400
H	-1.89063600	-2.20678800	2.46721200
H	-3.42367100	-1.31125200	2.34989300
H	-3.34752300	-3.00611000	1.82934100
C	-1.01577900	4.30901100	0.11793000
C	-1.70672400	3.08614100	0.15765900
H	-1.42741200	5.30510800	0.20615000
H	-2.76246300	2.88704900	0.29487100
N	0.37103500	2.61180800	-0.11696600
C	1.03943300	0.34208700	-0.27635800
C	1.43951300	1.70250700	-0.26332600
C	2.11466500	-0.55954500	-0.39308700
C	2.75305200	2.14953500	-0.35567400
C	3.44756900	-0.15331000	-0.47865500
H	1.91926600	-1.63261500	-0.37572400
C	3.77282000	1.21377000	-0.46153300
H	2.98988300	3.21365500	-0.34941100
H	4.79997900	1.55236300	-0.59642700
C	4.50249300	-1.18931500	-0.59061100
O	4.36447200	-2.28160900	-1.08273700
O	5.71780200	-0.83453100	-0.08163700
C	1.11844500	0.56325000	3.14496300
H	1.53426200	0.50089300	4.16122700
H	1.91542500	0.32386900	2.43137100
H	0.76757500	1.58826400	2.96633400

C	-0.01319200	-0.44373300	3.02174900
H	-0.44563000	-0.00051900	1.64404200
H	-0.98199500	-0.05649500	3.43499800
O	0.22241500	-1.66746700	3.07219300
C	0.30899800	3.96982200	-0.05478100
N	-0.86271200	2.06011800	0.01419000
H	1.19888300	4.57886500	-0.13326000
Ru	-0.94840900	-0.03654800	-0.00401200
H	5.60181700	-0.01176500	0.41075800



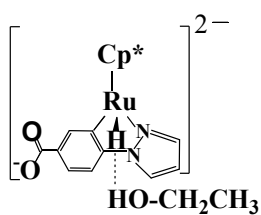
**Ru-20**

**55**

**E=-1284.2965279(au)**

C	-2.62958700	-0.39489700	-1.41560300
C	-3.11518000	-0.77291400	-0.10740600
C	-2.24717200	-1.79883700	0.38051800
C	-1.50688900	-1.21866400	-1.74122600
C	-1.25159900	-2.08562400	-0.61582600
C	-4.35615300	-0.26096300	0.54441400
H	-5.25653500	-0.82760700	0.25134900
H	-4.28013700	-0.30794600	1.63794700
H	-4.54272100	0.78864500	0.27910300
C	-3.25614900	0.64747300	-2.28104500
H	-2.58199000	0.94749900	-3.09193400
H	-4.19726000	0.30246200	-2.73759400
H	-3.48605300	1.55465700	-1.70395600
C	-0.73982700	-1.22588600	-3.02128800
H	0.33331000	-1.36481700	-2.84041100
H	-1.06741100	-2.03159000	-3.69707800
H	-0.85072300	-0.27518200	-3.55695300
C	-0.25958200	-3.19928000	-0.55965200
H	0.19031800	-3.28418100	0.43714600
H	-0.71734500	-4.17102500	-0.80690000
H	0.55819900	-3.04082100	-1.27389100
C	-2.38918300	-2.53682100	1.67087400
H	-1.41026100	-2.84970100	2.05393400
H	-2.86126000	-1.91050900	2.43837400
H	-3.00744900	-3.44006400	1.54906100
C	-1.23941900	4.28269400	0.64496300
C	-1.88610400	3.04100100	0.51811900

H	-1.68996500	5.24522200	0.84606300
H	-2.93399500	2.78645700	0.61754600
N	0.21523200	2.67624600	0.23990100
C	0.95272500	0.46856400	-0.21090800
C	1.30897400	1.83699300	-0.04047700
C	2.05749800	-0.35348500	-0.52608700
C	2.59747200	2.34869100	-0.13821000
C	3.36589000	0.12215000	-0.63684200
H	1.90820500	-1.42699300	-0.65128000
C	3.64518000	1.48662400	-0.43396100
H	2.79077200	3.41359700	-0.00447900
H	4.64571900	1.89048900	-0.58883700
C	4.44814700	-0.83924200	-0.95531300
O	4.31941000	-1.87068100	-1.56758800
O	5.68469900	-0.49088800	-0.49169700
C	1.87512800	-0.35822200	2.99541000
H	2.57371200	-0.53313300	3.82598300
H	2.43262000	-0.41353900	2.05354600
H	1.43368500	0.63747600	3.09731500
C	0.82336100	-1.42931800	3.02350100
H	-0.59147500	0.00982700	1.65789100
H	-0.14135200	-1.14761800	3.50438500
O	1.01116900	-2.56411900	2.63628100
C	0.10063000	4.01573300	0.46617600
N	-0.99974800	2.06977300	0.27264400
H	0.96880400	4.66008500	0.48242100
Ru	-1.00479600	0.00114100	0.05818200
H	5.57203900	0.26684500	0.09664800



### Ru-21

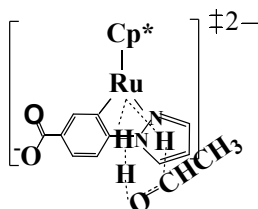
56

E=-1285.0530838(au)

C	1.46871900	-1.62103200	1.63181100
C	2.39742300	-1.64079400	0.52068000
C	1.70375200	-2.21054500	-0.59244600
C	0.23449800	-2.20715000	1.20835200
C	0.36813300	-2.56666800	-0.18613700
C	3.83407900	-1.23823900	0.56579500
H	4.50711600	-2.06344300	0.86556600

H	4.16997400	-0.87066900	-0.41292500
H	3.99309300	-0.42219800	1.28569000
C	1.78622900	-1.10007800	2.99379400
H	0.87342700	-0.98106700	3.59013800
H	2.46883500	-1.76313200	3.55216800
H	2.26303200	-0.10975300	2.94304800
C	-0.98553400	-2.44317000	2.03501300
H	-1.89403200	-2.17458700	1.47961900
H	-1.08170800	-3.49604000	2.34796900
H	-0.97677700	-1.82335700	2.94088200
C	-0.62036500	-3.33880200	-0.99377100
H	-0.61109000	-3.01573900	-2.04225400
H	-0.42389100	-4.42563600	-0.97340700
H	-1.64272600	-3.18209500	-0.62941600
C	2.29294500	-2.51228400	-1.93224900
H	3.08726800	-1.80307400	-2.19173900
H	2.71436800	-3.53121400	-1.96956800
H	1.52845100	-2.44015600	-2.71536500
C	1.37355400	3.60923700	1.47812500
C	1.84124700	2.32517600	1.16253200
H	1.93964800	4.44462400	1.86975700
H	2.84078500	1.91117000	1.22460700
N	-0.26240100	2.34031000	0.70649200
C	-1.33012700	0.37067300	-0.08372900
C	-1.47397500	1.71470900	0.31855900
C	-2.55047800	-0.24875600	-0.42941500
C	-2.69005800	2.40053300	0.38235000
C	-3.79315500	0.38217600	-0.36000200
H	-2.56316000	-1.28219000	-0.77857800
C	-3.85048700	1.72396900	0.04271800
H	-2.72890400	3.44619800	0.70050300
H	-4.83409100	2.18912600	0.07668200
H	0.58268200	0.24233800	-1.55867200
C	-5.10486300	-0.36167800	-0.70739200
O	-4.98598700	-1.56774700	-1.02168800
O	-6.14963300	0.33049000	-0.62874000
C	2.35121300	2.97493400	-2.17542500
H	2.15724400	3.08224500	-3.25008800
H	1.41941300	2.65492300	-1.69199200
H	2.63444400	3.95290500	-1.76196500
C	3.43087300	1.93668500	-1.93071300
H	3.64602400	1.89738800	-0.84541300
H	4.36958400	2.23925800	-2.42504400
O	3.09228500	0.67426400	-2.42854100

H	2.25782900	0.40386800	-1.96893300
C	0.02481300	3.58433100	1.17022400
N	0.84442100	1.56029100	0.68619100
H	-0.74553400	4.33923100	1.24856400
Ru	0.59251400	-0.39587600	-0.01679300



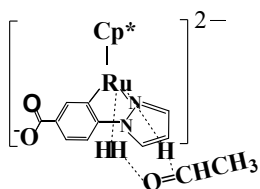
**Ru-TS<sub>21-22</sub>**

**56 -254.86i cm<sup>-1</sup>**

**E=-1285.0108456(au)**

C	-1.39601100	-1.35104000	-1.78834900
C	-2.49941200	-1.36921700	-0.84924500
C	-2.03615200	-2.02269500	0.33016400
C	-0.28461400	-2.08103100	-1.20363100
C	-0.67882800	-2.47876100	0.12386500
C	-3.86231900	-0.79205300	-1.03968100
H	-4.61743000	-1.55588400	-1.29419900
H	-4.20262000	-0.28169300	-0.12808700
H	-3.87033600	-0.05135600	-1.85122700
C	-1.44105100	-0.80318700	-3.17561600
H	-0.44241100	-0.49128300	-3.50430500
H	-1.82304600	-1.53869400	-3.90280700
H	-2.08678400	0.08296200	-3.23141800
C	0.99082400	-2.44304500	-1.88600600
H	1.83009500	-2.47707000	-1.18113200
H	0.92005800	-3.42471000	-2.38112400
H	1.25836800	-1.69891000	-2.64593800
C	0.11418300	-3.29928600	1.08461500
H	-0.06460000	-2.97073000	2.11527700
H	-0.13766300	-4.37148600	1.02393800
H	1.19055500	-3.20017200	0.90026700
C	-2.83785000	-2.21557200	1.57697000
H	-2.84961900	-1.31366600	2.22961300
H	-3.87803400	-2.46977700	1.32559600
H	-2.43070400	-3.04368400	2.17164000
C	-1.18932800	3.86709400	-1.22992300
C	-1.73682800	2.59093200	-1.04937600
H	-1.70331600	4.78006600	-1.49905100
H	-2.76605000	2.25449000	-1.10420500
N	0.36917000	2.41420300	-0.65165400

C	1.29776200	0.34467200	0.07597500
C	1.53640600	1.68152300	-0.28802000
C	2.45872000	-0.37169800	0.41930100
C	2.79818900	2.27789100	-0.33056600
C	3.74585100	0.16534200	0.37018300
H	2.39327300	-1.41365700	0.73741700
C	3.90250800	1.50617500	-0.00061700
H	2.91807600	3.32201000	-0.63055600
H	4.91845400	1.89649300	-0.02432100
H	-0.34822800	-0.28116800	2.25511800
C	4.99502100	-0.69591600	0.67334200
O	4.77638900	-1.90668100	0.90255700
O	6.08758300	-0.08096200	0.63919600
C	-2.18503300	2.64917800	2.47323000
H	-2.70042100	3.09726600	3.33584200
H	-1.11446200	2.58400800	2.71745200
H	-2.30076300	3.31516600	1.60200500
C	-2.71797100	1.23043800	2.21010700
H	-2.10066900	0.86321600	1.31081800
H	-3.75445200	1.33141400	1.74880700
O	-2.64433600	0.41649500	3.25208400
H	-0.95103200	-0.16250300	2.75425300
C	0.16143300	3.71380100	-0.96075800
N	-0.78567600	1.71806100	-0.70253900
H	0.97711400	4.42373000	-0.95696800
Ru	-0.67995200	-0.32232600	-0.09045100



**Ru-22**

**56**

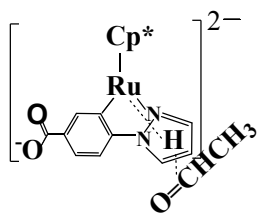
**E=-1285.0193568(au)**

C	-1.88156300	-1.09803900	-1.71603100
C	-2.76550100	-1.16631800	-0.57729000
C	-2.08947800	-1.93209000	0.42870600
C	-0.69745900	-1.87750600	-1.43221400
C	-0.83043500	-2.39452000	-0.08893600
C	-4.12152100	-0.55971500	-0.43227300
H	-4.93901900	-1.27986700	-0.61515900
H	-4.25984700	-0.15512000	0.57971300
H	-4.26436100	0.27125100	-1.13749700
C	-2.17852400	-0.40642400	-3.00506500

H	-1.25377600	-0.06751800	-3.48790600
H	-2.71340000	-1.05709200	-3.71600400
H	-2.79848000	0.48561400	-2.84283000
C	0.42639700	-2.17303900	-2.36777600
H	1.38630800	-2.17821600	-1.83638600
H	0.30907800	-3.14934500	-2.86643200
H	0.50390000	-1.40376300	-3.14651200
C	0.09853800	-3.34747400	0.58640700
H	0.21642000	-3.10704600	1.65012200
H	-0.25824600	-4.38877100	0.51572200
H	1.10094800	-3.31130000	0.14490000
C	-2.62959800	-2.19924900	1.79367200
H	-2.60531000	-1.28843300	2.43101300
H	-3.67212700	-2.54711800	1.73125800
H	-2.04572500	-2.97711100	2.30073500
C	-1.04192700	4.04070900	-0.97031900
C	-1.67901400	2.80207400	-0.81541800
H	-1.49725000	5.00620000	-1.14679500
H	-2.73251100	2.54849800	-0.81820300
N	0.43195200	2.43377500	-0.61936300
C	1.22261800	0.27729500	0.00403900
C	1.55283700	1.59757900	-0.35627100
C	2.34381600	-0.53723000	0.26055100
C	2.85418100	2.08956400	-0.47613800
C	3.66541500	-0.10336300	0.13775700
H	2.21637300	-1.57505500	0.57129300
C	3.90993100	1.22599200	-0.22788000
H	3.03917300	3.12585800	-0.77101800
H	4.95113300	1.53253800	-0.31009700
H	0.19578400	-1.17720000	2.98066800
C	4.85936700	-1.06167600	0.36528400
O	4.56302000	-2.25004600	0.62223200
O	5.99347200	-0.53645600	0.25342000
C	-0.61808700	2.17982100	2.86759200
H	-1.05484300	2.87696100	3.59803500
H	0.20945700	1.64733200	3.35319900
H	-0.21462500	2.75493700	2.02095700
C	-1.69276900	1.17736700	2.41984500
H	-1.02315900	0.50112700	1.62473400
H	-2.39323700	1.70211200	1.70694100
O	-2.23228000	0.45030000	3.34231100
H	-0.31012400	-0.88185100	3.45161100
C	0.30858500	3.76445900	-0.83236100
N	-0.77856800	1.83382200	-0.60865800



H	1.17864200	4.40636400	-0.85402500
Ru	-0.80757800	-0.21106500	-0.08306600



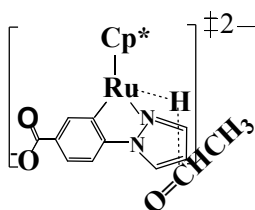
### Ru-23

54

**E=-1283.8435246(au)**

C	-2.17639900	-1.10095800	-1.49428700
C	-2.75039300	-1.24206000	-0.19224300
C	-1.81088400	-2.01181400	0.59776100
C	-0.91684400	-1.82032900	-1.53670400
C	-0.71236400	-2.40688200	-0.23206900
C	-4.01917200	-0.66490300	0.34520600
H	-4.82155200	-1.41896600	0.42185800
H	-3.83920200	-0.24376000	1.35084300
H	-4.39496100	0.14331500	-0.29878900
C	-2.76923200	-0.36450400	-2.64963000
H	-1.99623100	0.19472800	-3.19285600
H	-3.26070800	-1.04231200	-3.36589400
H	-3.51931000	0.36267000	-2.31270900
C	-0.06226400	-2.04003700	-2.73914100
H	0.99638100	-2.09666900	-2.45910300
H	-0.31877000	-2.96916200	-3.27754500
H	-0.15973400	-1.20752600	-3.44774000
C	0.38434800	-3.34584900	0.13782600
H	0.63896900	-3.26611700	1.20105600
H	0.10355500	-4.39278800	-0.06316400
H	1.30587600	-3.13510600	-0.41603400
C	-2.01511900	-2.32946200	2.03958100
H	-2.26609800	-1.40865400	2.60165700
H	-2.84342800	-3.04538800	2.17145500
H	-1.11315400	-2.77285200	2.47802100
C	-0.99863500	3.99641100	-1.07730700
C	-1.62641800	2.74883700	-0.96213000
H	-1.45707900	4.95717100	-1.27045600
H	-2.67451000	2.48056100	-1.02160100
N	0.47535100	2.40564800	-0.66180300
C	1.27123800	0.26009500	0.00940100
C	1.59488300	1.58114900	-0.35762400
C	2.40130700	-0.53265800	0.29601300

C	2.89105400	2.09110500	-0.45586200
C	3.71953400	-0.08159700	0.19656800
H	2.28818700	-1.56878700	0.61311200
C	3.95412800	1.24679500	-0.17746400
H	3.06667600	3.12596800	-0.76098900
H	4.99228400	1.56740500	-0.24443700
C	4.91958400	-1.02229900	0.45931000
O	4.63218700	-2.21031900	0.72837700
O	6.05008800	-0.48620800	0.36094600
C	-0.74663100	2.07230700	3.02765000
H	-1.21555700	2.79346700	3.71388900
H	-0.10817500	1.40212400	3.61658800
H	-0.11430400	2.61631500	2.30928500
C	-1.83323100	1.26011800	2.30835600
H	-1.11576000	0.58755300	1.56132500
H	-2.32960200	1.93645500	1.55124000
O	-2.62499900	0.54375700	3.04056500
C	0.34638600	3.73561300	-0.87265100
N	-0.72516900	1.79117100	-0.71630500
H	1.20807800	4.38857700	-0.84353900
Ru	-0.77342300	-0.23450600	-0.09161800



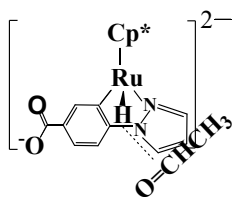
**Ru-TS<sub>23-24</sub>**

**54 -495.41i cm<sup>-1</sup>**

**E=-1283.8339995(au)**

C	-2.16087100	-1.16438300	-1.47648500
C	-2.74747500	-1.23737500	-0.16575000
C	-1.82830700	-1.98896400	0.65418400
C	-0.93644000	-1.92333100	-1.49106600
C	-0.73002200	-2.43021000	-0.15541400
C	-4.03881900	-0.65582200	0.30834300
H	-4.86315500	-1.39129500	0.32424900
H	-3.92546700	-0.25375100	1.32670700
H	-4.36328900	0.17387600	-0.33653300
C	-2.75352600	-0.47897300	-2.66390300
H	-1.97157300	-0.01829900	-3.28168500
H	-3.32322500	-1.17135100	-3.30504200
H	-3.43827600	0.32405000	-2.36073600
C	-0.07112200	-2.20692900	-2.67267100

H	0.98767100	-2.22606300	-2.38548900
H	-0.30392800	-3.17453600	-3.15187400
H	-0.17737600	-1.42640800	-3.43723400
C	0.35275600	-3.36774300	0.25846200
H	0.61517900	-3.23601900	1.31485400
H	0.05991800	-4.42124000	0.11237300
H	1.27460200	-3.19664900	-0.30899800
C	-2.05421700	-2.31235500	2.09387700
H	-2.40813200	-1.42931400	2.64336500
H	-2.80125100	-3.11569000	2.21140000
H	-1.12462300	-2.64672300	2.56961900
C	-1.00374700	3.94648200	-1.20069000
C	-1.62996200	2.70636200	-1.01019700
H	-1.46562200	4.89296800	-1.45038100
H	-2.67830400	2.43496800	-1.05765700
N	0.47669400	2.38287200	-0.70619200
C	1.27653100	0.25115400	-0.01631700
C	1.59788800	1.57360400	-0.38807600
C	2.41116000	-0.53484400	0.28321800
C	2.89404800	2.08943900	-0.47565200
C	3.72642400	-0.07726500	0.19293600
H	2.29750800	-1.56905100	0.60792300
C	3.95851100	1.25279200	-0.18502300
H	3.06651000	3.12599100	-0.77821900
H	4.99547400	1.57933300	-0.24064500
C	4.93040600	-1.00490900	0.48281800
O	4.65148700	-2.18871100	0.77936700
O	6.05938600	-0.46495100	0.37962000
C	-0.79020000	2.30919900	2.80885100
H	-1.21555800	3.15106800	3.37959600
H	-0.12949900	1.74359700	3.47355700
H	-0.20192200	2.70335700	1.97229700
C	-1.92665600	1.42736000	2.32732600
H	-0.79939800	0.43355700	1.49540200
H	-2.38438000	1.77463600	1.37419900
O	-2.59295100	0.74388500	3.12156700
C	0.34329500	3.70218100	-0.99407100
N	-0.72418800	1.76111600	-0.71333900
H	1.20473500	4.35580500	-1.01462000
Ru	-0.75126100	-0.23634800	-0.07028100



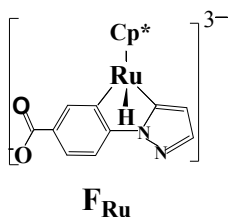
**Ru-24**

**54**

**E=-1283.8374356(au)**

C	1.51762800	-1.63266100	1.60847900
C	2.46383300	-1.51918400	0.51707200
C	1.83649100	-2.05777800	-0.64549100
C	0.33332100	-2.26733400	1.11773200
C	0.51696500	-2.52866300	-0.29330100
C	3.86836600	-1.02388800	0.63004000
H	4.57979700	-1.81893200	0.91750200
H	4.22786700	-0.59166600	-0.31396400
H	3.95175100	-0.23921600	1.39730100
C	1.77404700	-1.15957400	3.00038800
H	0.84378600	-1.12974900	3.58093600
H	2.49077100	-1.79781300	3.54624200
H	2.18075500	-0.13656500	2.99958200
C	-0.87839000	-2.64232500	1.90476300
H	-1.79751100	-2.39896900	1.35599500
H	-0.90471600	-3.71822400	2.14473400
H	-0.92181100	-2.08602700	2.84981700
C	-0.40665900	-3.30936000	-1.16680200
H	-0.35539700	-2.96137700	-2.20609700
H	-0.18273600	-4.39123200	-1.16268900
H	-1.44948200	-3.18716600	-0.84930500
C	2.46945400	-2.19243100	-1.99326800
H	3.19632700	-1.39143200	-2.17893900
H	2.99243800	-3.15706400	-2.10787300
H	1.71196400	-2.12769900	-2.78339300
C	1.29639600	3.66621800	1.41750300
C	1.77807600	2.37433600	1.15656800
H	1.85060400	4.51872700	1.78942400
H	2.77959600	1.96875000	1.24735200
N	-0.32589800	2.35544000	0.68363200
C	-1.36225000	0.34240000	-0.03535900
C	-1.52583300	1.70113800	0.31242200
C	-2.57086200	-0.30402400	-0.37464200
C	-2.75078200	2.37449500	0.33098400
C	-3.82011800	0.31614800	-0.35179900
H	-2.56674300	-1.35021400	-0.68657700

C	-3.89762500	1.67217800	-0.00111500
H	-2.80589900	3.43159800	0.60646400
H	-4.88667300	2.12677000	-0.00280800
C	-5.11870000	-0.44907600	-0.70159800
O	-4.98492300	-1.66304300	-0.97701600
O	-6.17010200	0.23676800	-0.66595300
C	2.19750700	2.71447900	-2.28948600
H	2.10792300	3.44317200	-1.47181400
H	2.58676600	3.19152600	-3.19479500
H	1.18624400	2.31633600	-2.44411100
C	3.07886500	1.58591500	-1.84785900
H	0.49424900	0.24768000	-1.52151100
H	2.67297700	1.00762500	-0.98528800
O	4.12069500	1.27862300	-2.40099000
C	-0.05036500	3.61995400	1.10073800
N	0.78793600	1.58370300	0.70022400
H	-0.82685800	4.37104500	1.14881800
Ru	0.57700400	-0.36860100	0.01395100

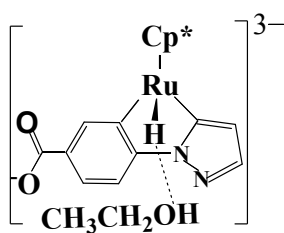


**46**

**E=-1129.5478198(au)**

C	2.19564500	-0.57559800	1.34963500
C	3.00842300	-0.66884600	0.15568500
C	2.41821900	-1.67651800	-0.67850900
C	1.12707300	-1.52525600	1.23778100
C	1.27914900	-2.24627400	-0.00600700
C	4.30635600	0.03498600	-0.05237700
H	5.16163000	-0.44821400	0.47541400
H	4.56747600	0.08486100	-1.11852900
H	4.25395300	1.07233100	0.30738500
C	2.46042400	0.36163600	2.48092500
H	1.57175600	0.46472900	3.11830500
H	3.30199900	0.04396400	3.12785700
H	2.69249100	1.37072600	2.10601800
C	0.05800000	-1.79676000	2.24391100
H	-0.92548900	-1.86468700	1.75698800
H	0.22725800	-2.73417400	2.80611100
H	-0.01364800	-0.97664700	2.97054800
C	0.48814500	-3.43858000	-0.42576900

H	0.44267300	-3.51993100	-1.52049300
H	0.89479500	-4.39935300	-0.04154700
H	-0.55127700	-3.36644000	-0.07875300
C	2.97698500	-2.16361000	-1.97659900
H	3.51423200	-1.35907900	-2.49735100
H	3.67499700	-3.01655300	-1.85481500
H	2.16918800	-2.48469600	-2.64679600
C	0.82934500	4.23208700	-0.13064300
C	1.67990700	3.11661700	-0.26687200
H	1.09747300	5.28971200	-0.06022700
H	2.76327800	3.10977400	-0.36451300
N	-0.41265200	2.53665200	-0.20429600
C	-1.14229500	0.29983100	-0.28344800
C	-1.51719100	1.66329500	-0.17333600
C	-2.23043600	-0.59715400	-0.23804600
C	-2.83134000	2.09936900	-0.03452900
C	-3.57561200	-0.21005700	-0.08439200
H	-2.05223000	-1.67173500	-0.33719100
C	-3.85845400	1.15579100	0.01210900
H	-3.02923800	3.17128600	0.04141700
H	-4.90385900	1.44508600	0.12354300
H	0.57878900	0.17021600	-2.03844300
C	-4.73095800	-1.23086200	-0.02614500
O	-4.42442000	-2.44788300	-0.10240000
O	-5.89265400	-0.75174900	0.09582000
C	0.84380500	1.98079600	-0.32301500
N	-0.46233200	3.89673200	-0.08726300
Ru	0.92077500	-0.06152700	-0.42871700



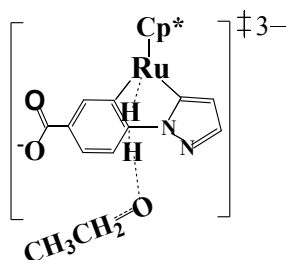
**55**

**E=-1284.5536511(au)**

C	1.55922500	-1.50177600	1.62168000
C	2.43650900	-1.58452400	0.47519700
C	1.69627900	-2.24569900	-0.56475900
C	0.31512000	-2.13883000	1.29107400
C	0.40491200	-2.62671400	-0.06794100
C	3.87461700	-1.18801600	0.42404500
H	4.57645800	-2.02972900	0.61687900

H	4.12829900	-0.75871400	-0.55561200
H	4.09014100	-0.41589600	1.17716500
C	1.92380300	-0.88390500	2.93121100
H	1.02598500	-0.70624000	3.53785000
H	2.61778700	-1.50693000	3.52704800
H	2.39239300	0.10101400	2.78299500
C	-0.87058000	-2.32431800	2.17924300
H	-1.79898000	-2.08393700	1.64194400
H	-0.96162100	-3.35597300	2.56852500
H	-0.82514500	-1.64310700	3.03980700
C	-0.60547100	-3.48208900	-0.75389900
H	-0.54499800	-3.36826100	-1.84455200
H	-0.49032800	-4.56295800	-0.52697400
H	-1.62709100	-3.19668200	-0.47020800
C	2.24982400	-2.60661800	-1.90642200
H	2.97662700	-1.85694200	-2.24403600
H	2.75212400	-3.59331900	-1.90371700
H	1.45217600	-2.64077300	-2.66016500
C	1.16686600	3.62634300	1.44060600
C	1.82098000	2.40575300	1.17708500
H	1.58616700	4.55061700	1.84473500
H	2.87588200	2.17941100	1.31712300
N	-0.28640600	2.32216800	0.65683900
C	-1.36576000	0.36796200	-0.09212200
C	-1.50962700	1.72481000	0.29126000
C	-2.58154400	-0.26556600	-0.42181100
C	-2.72761900	2.39635900	0.33754400
C	-3.84099600	0.36102100	-0.37152600
H	-2.58377100	-1.30779400	-0.75230600
C	-3.89354800	1.70592500	0.00619700
H	-2.74437500	3.44447700	0.64479000
H	-4.87495200	2.18004300	0.03401900
H	0.57839600	0.30548600	-1.56778200
C	-5.14718400	-0.38493800	-0.71581300
O	-5.04577100	-1.59862700	-1.02673800
O	-6.20905700	0.29356800	-0.65101200
C	0.84616300	1.53412400	0.64101900
N	-0.13029000	3.59284400	1.13143800
C	2.50028300	3.00645700	-2.13061200
H	2.34344000	3.14143500	-3.21033600
H	1.54075900	2.76132100	-1.65714900
H	2.85445300	3.95278300	-1.69575900
C	3.48466700	1.88054100	-1.86958900
H	3.62569800	1.79386500	-0.77669100

H	4.47078000	2.12513700	-2.30908900
O	3.07648100	0.66215100	-2.42486800
H	2.23578400	0.41205700	-1.94780800
Ru	0.59659200	-0.38272800	-0.04176600



**Ru-TS<sub>25-26</sub>**

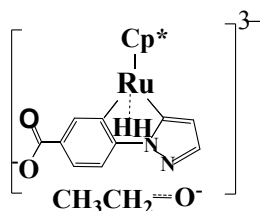
**55 -949.95i cm<sup>-1</sup>**

**E=-1284.5238377(au)**

C	1.48741000	-1.29234300	1.73625300
C	2.38876100	-1.55652500	0.64457200
C	1.64483900	-2.30420400	-0.33574300
C	0.21944800	-1.90875200	1.44373000
C	0.32803300	-2.56907600	0.15903500
C	3.82704400	-1.17820600	0.53162700
H	4.52264300	-2.00441500	0.79001200
H	4.03864500	-0.85288700	-0.49658600
H	4.06312000	-0.33355600	1.19448000
C	1.84116700	-0.55035500	2.98277100
H	0.93903800	-0.16532000	3.47502500
H	2.38884500	-1.17702500	3.71004200
H	2.45893500	0.32769500	2.74895000
C	-0.98845000	-1.95180700	2.31983200
H	-1.89980900	-1.77400400	1.73236000
H	-1.10203800	-2.92013100	2.84128800
H	-0.95044200	-1.16151300	3.08141000
C	-0.70808300	-3.44811500	-0.45593100
H	-0.64376800	-3.43153000	-1.55180800
H	-0.62333600	-4.50512700	-0.13359100
H	-1.72062100	-3.10935000	-0.20255500
C	2.21913300	-2.76903300	-1.63643400
H	2.76430900	-1.94214100	-2.11475200
H	2.90800200	-3.62316700	-1.49835900
H	1.42488700	-3.08874700	-2.32386400
C	1.12082500	3.72034900	1.30798900
C	1.80057600	2.51459900	1.04258400
H	1.52774600	4.66430100	1.67563200
H	2.86799600	2.32192900	1.11476600
N	-0.32270600	2.36030300	0.61290000



C	-1.35519900	0.40079900	-0.18420300
C	-1.53162000	1.73960900	0.23632800
C	-2.54916800	-0.25453400	-0.53913500
C	-2.76600700	2.37850500	0.30105300
C	-3.82477600	0.33702700	-0.47088100
H	-2.52387800	-1.28628000	-0.89702300
C	-3.91226800	1.66700000	-0.05306400
H	-2.80847500	3.41694900	0.63569500
H	-4.90587900	2.11390200	-0.01439300
H	0.73356400	0.30353000	-1.65561600
C	-5.10892100	-0.43890100	-0.83065300
O	-4.97067100	-1.64787300	-1.14378700
O	-6.18654300	0.21330000	-0.77065300
C	0.82965800	1.60984700	0.57672900
N	-0.18730600	3.64134400	1.05454700
C	2.99599100	2.67119600	-2.41148400
H	2.75123900	2.72258400	-3.48341400
H	2.06328100	2.75420200	-1.83874800
H	3.63387100	3.53462400	-2.15094300
C	3.67562000	1.33468000	-2.08853900
H	3.93118600	1.37798100	-0.99229100
H	4.68360900	1.35188700	-2.59806400
O	2.94382900	0.25034500	-2.43399400
H	1.66443600	0.24248900	-1.72608300
Ru	0.62013600	-0.34557200	-0.04238300



**Ru-26**

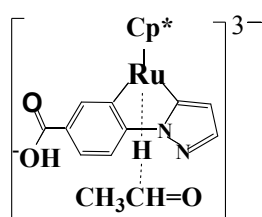
55

**E=-1284.5302805(au)**

C	0.99739100	-0.17736800	1.82217300
C	2.17307000	-0.32718400	0.99267200
C	1.97555800	-1.49547300	0.19727800
C	0.12208300	-1.28741200	1.57479400
C	0.71473600	-2.09773300	0.55568400
C	3.41812400	0.50697600	1.07411800
H	3.61513000	0.79030000	2.12056200
H	4.30735200	-0.03802100	0.70478200
H	3.33044300	1.44253900	0.50441600
C	0.79962100	0.90186100	2.83545000

H	-0.26840700	1.08486700	3.01182800
H	1.27345600	0.66271700	3.80330600
H	1.22303000	1.84609700	2.47027600
C	-1.15378300	-1.58828300	2.28727600
H	-1.92625800	-1.95149900	1.59761800
H	-1.00614500	-2.34777200	3.07318700
H	-1.56341900	-0.68714800	2.75964700
C	0.17920800	-3.39723800	0.05128500
H	0.51089200	-3.58472400	-0.97784500
H	0.50626200	-4.25759400	0.66415900
H	-0.91825900	-3.39540000	0.04079800
C	2.97098700	-2.08204300	-0.76164700
H	3.99441900	-1.69744900	-0.59787600
H	3.00922900	-3.17633700	-0.64318400
H	2.69878000	-1.88400300	-1.80788800
C	-0.10090800	4.25574600	-0.00663100
C	0.82688300	3.19670600	-0.08735300
H	0.09504500	5.32291200	0.10298600
H	1.91092800	3.25353500	-0.05787800
N	-1.22452300	2.49354500	-0.21024700
C	-1.80546500	0.22699100	-0.41964800
C	-2.26966600	1.55557600	-0.32039200
C	-2.81026300	-0.74440900	-0.54963100
C	-3.61702000	1.90283600	-0.33007400
C	-4.18448500	-0.44692300	-0.55623600
H	-2.54888200	-1.80130000	-0.65086100
C	-4.56942400	0.89137000	-0.44614100
H	-3.89445000	2.95483400	-0.24566400
H	-5.63826300	1.10385700	-0.45782500
H	0.00402200	-0.29511500	-1.92862600
C	-5.25624300	-1.55137700	-0.67704500
O	-4.83754400	-2.73406000	-0.71871000
O	-6.45098900	-1.15646600	-0.71841300
C	0.06720900	2.02676700	-0.22134700
N	-1.36654000	3.83934600	-0.08217700
C	5.91384900	0.11730100	-2.22316200
H	5.90282800	-0.82608600	-2.79190300
H	4.86489700	0.39792000	-2.04377000
H	6.38809300	0.90236900	-2.84366500
C	6.62613700	-0.11086500	-0.86683100
H	6.64266700	0.93611900	-0.39172000
H	7.73829400	-0.24173000	-1.15211100
O	6.10701000	-1.07232800	-0.13381100
H	0.67026600	0.31891600	-1.89433000

Ru                    0.28550200    -0.02534400    -0.25685300



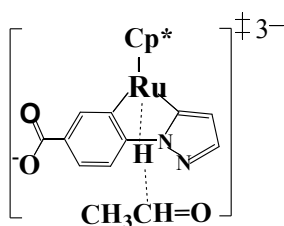
**Ru-27**

**53**

**E=-1283.3451705(au)**

C	-2.13618000	-0.73850700	-1.64164600
C	-2.76102000	-1.13106800	-0.41582700
C	-1.86712800	-2.07477000	0.23213000
C	-0.87365200	-1.45189600	-1.76708500
C	-0.74773300	-2.32395300	-0.61360300
C	-4.04729300	-0.64905300	0.17309500
H	-4.87990500	-1.36629800	0.03163000
H	-3.91796500	-0.47120700	1.25757500
H	-4.35588200	0.30309900	-0.28404400
C	-2.70820500	0.17636400	-2.67306100
H	-1.91647900	0.76063900	-3.15876400
H	-3.26261500	-0.37010700	-3.45843700
H	-3.39475300	0.90305000	-2.21900600
C	0.03065300	-1.44587400	-2.95419900
H	1.07274100	-1.59410800	-2.64467100
H	-0.21843900	-2.23101900	-3.69521600
H	-0.00893300	-0.47550900	-3.46691300
C	0.32664500	-3.33692500	-0.40891400
H	0.46061800	-3.56476400	0.65621300
H	0.10900600	-4.28920200	-0.92930300
H	1.29894900	-2.97760700	-0.76738700
C	-2.13883800	-2.66620300	1.57510900
H	-2.40997700	-1.86569000	2.29373500
H	-2.97572200	-3.38871500	1.53505000
H	-1.25693800	-3.19682400	1.95815700
C	-0.71748800	4.08741800	-0.85079300
C	-1.55656600	2.96314900	-0.72076100
H	-0.99187800	5.12409400	-1.05536300
H	-2.64198900	2.93156800	-0.77438400
N	0.53434800	2.44521100	-0.45991400
C	1.29990900	0.27747100	0.07738800
C	1.65200500	1.61914600	-0.20275800
C	2.40189000	-0.56523300	0.31717900
C	2.96013000	2.09029300	-0.24648500

C	3.74493500	-0.14690700	0.26379700
H	2.24701200	-1.61770500	0.56211900
C	4.00519100	1.19589300	-0.01601500
H	3.13890700	3.14423800	-0.46772200
H	5.05027600	1.50448900	-0.04919400
C	4.91962700	-1.12375400	0.48015100
O	4.62490700	-2.33178500	0.65854600
O	6.07403200	-0.61766700	0.44831300
C	-0.71400500	1.86953500	-0.46294400
N	0.57367100	3.78278500	-0.69759700
C	-0.98139600	1.48031800	3.49921900
H	-1.48917400	2.04406500	4.30031900
H	-0.36034200	0.70531000	3.96943600
H	-0.32533000	2.15802400	2.93178500
C	-2.01622100	0.81795700	2.57423900
H	-1.29291100	0.36139000	1.73452200
H	-2.51461100	1.64399400	1.98598700
O	-2.82449300	-0.05410000	3.12751900
Ru	-0.78106600	-0.16552700	-0.07563400



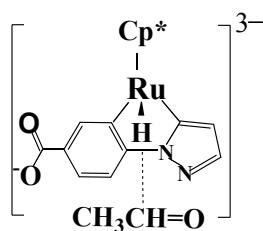
**Ru-TS<sub>27-28</sub>**

**53 -493.50i cm<sup>-1</sup>**

**E=-1283.3342732(au)**

C	-2.02952000	-1.08021100	-1.58251000
C	-2.74708400	-1.20153600	-0.33818500
C	-1.93514100	-2.02228300	0.52778800
C	-0.82737100	-1.87445300	-1.50387100
C	-0.78297700	-2.47471600	-0.18747200
C	-4.05891400	-0.58878500	0.02644700
H	-4.92538000	-1.27006800	-0.10103700
H	-4.04843300	-0.25736100	1.07724000
H	-4.25911300	0.30100900	-0.59051600
C	-2.51252300	-0.33243400	-2.78155600
H	-1.67936400	-0.10558700	-3.45964300
H	-3.27730500	-0.88930500	-3.35554400
H	-2.94229100	0.63626000	-2.49065100
C	0.17129900	-2.11990200	-2.58532100
H	1.19206800	-2.08603000	-2.18014000
H	0.04244800	-3.09818300	-3.08908800

H	0.11603700	-1.33856900	-3.35555700
C	0.22938900	-3.46609400	0.27614000
H	0.34096500	-3.43925600	1.36792900
H	-0.02339000	-4.50752600	-0.00942900
H	1.22250200	-3.24528800	-0.13465700
C	-2.31141400	-2.39226300	1.92595500
H	-2.66572100	-1.51088000	2.47908400
H	-3.10702300	-3.16162000	1.95040100
H	-1.44463400	-2.79227600	2.46840200
C	-0.84389200	3.91363800	-1.20339100
C	-1.63477200	2.76478400	-0.99988000
H	-1.16084200	4.91518800	-1.50298700
H	-2.71608000	2.67876400	-1.08958300
N	0.47152100	2.37099200	-0.64236100
C	1.30429100	0.26986400	0.01718800
C	1.61575000	1.60971000	-0.32430000
C	2.43658200	-0.52312200	0.29933000
C	2.90760500	2.12565800	-0.37054800
C	3.76357500	-0.05820400	0.24605200
H	2.31322700	-1.56914800	0.59015900
C	3.98089800	1.28250000	-0.08493700
H	3.05159100	3.17457100	-0.63909300
H	5.01407200	1.62907500	-0.11335100
C	4.97157400	-0.97434200	0.53363800
O	4.72410200	-2.17843900	0.79506400
O	6.10805600	-0.42955000	0.47491000
C	-0.74970800	1.73367600	-0.62238800
N	0.45484000	3.68917100	-0.99022000
C	-1.07391300	2.32517800	2.80016900
H	-1.58699700	3.16660700	3.30106600
H	-0.41811500	1.84204500	3.53311100
H	-0.47053600	2.70915900	1.97020200
C	-2.12181500	1.34486000	2.31014200
H	-0.79122000	0.39172100	1.55939000
H	-2.53302400	1.59462500	1.31247700
O	-2.77557000	0.64846200	3.10963900
Ru	-0.74300400	-0.22913600	-0.03131700

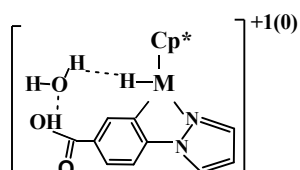


**Ru-28**

**E=-1283.3382727(au)**

C	1.74508700	-1.23392000	1.67596900
C	2.59710800	-1.33407500	0.51449400
C	1.86683100	-2.08360700	-0.47222400
C	0.53471900	-1.96238400	1.42007500
C	0.61697200	-2.51348500	0.08539000
C	4.00123600	-0.84108700	0.39859500
H	4.75897100	-1.57653900	0.73985600
H	4.24629900	-0.57553400	-0.64069000
H	4.15090900	0.06602400	1.00567100
C	2.11274700	-0.52613500	2.93865000
H	1.22965000	-0.38251700	3.57509900
H	2.87286100	-1.06979700	3.53273000
H	2.50434900	0.47992600	2.72564100
C	-0.61163800	-2.17362300	2.35262400
H	-1.56676700	-2.01941800	1.83064500
H	-0.62834900	-3.18693400	2.79695200
H	-0.58616500	-1.44654100	3.17560200
C	-0.35575600	-3.46526200	-0.52391700
H	-0.37296600	-3.37055200	-1.61770500
H	-0.13475500	-4.52670600	-0.28515700
H	-1.37945500	-3.26164500	-0.18482500
C	2.38996800	-2.45232200	-1.82341900
H	2.98712800	-1.63482700	-2.24638100
H	3.01837700	-3.36356600	-1.80013900
H	1.56131900	-2.63655200	-2.51947600
C	0.92960800	3.84370600	1.24521500
C	1.67492700	2.66772200	1.02496300
H	1.28075400	4.81641600	1.59788700
H	2.74548200	2.52946700	1.16658600
N	-0.43030800	2.39161900	0.56081400
C	-1.34785900	0.32596500	-0.09251600
C	-1.60272500	1.68239800	0.23218100
C	-2.50877900	-0.41863100	-0.38869800
C	-2.87170600	2.25343000	0.25612400
C	-3.81463800	0.10511100	-0.36032900
H	-2.42509500	-1.46992500	-0.67535800
C	-3.97739000	1.45635800	-0.03983100
H	-2.97404800	3.30901700	0.51794500
H	-4.99414700	1.84951700	-0.02803000
C	-5.05630100	-0.75770500	-0.66936900
O	-4.85783900	-1.97213600	-0.92530400
O	-6.16874600	-0.16337100	-0.63421500

C	0.76043400	1.69381600	0.56299900
N	-0.36712700	3.69236600	0.96924100
C	1.90986800	2.40855000	-2.57876400
H	2.49699800	3.31042700	-2.82602900
H	1.45324400	2.03661600	-3.50289500
H	1.13260200	2.66573100	-1.85285500
C	2.84689500	1.37255300	-2.01380500
H	0.59429300	0.27675900	-1.59073500
H	2.89444000	1.32937600	-0.91032900
O	3.59774700	0.70830000	-2.72631500
Ru	0.66157200	-0.26369800	-0.01986800



H<sub>2</sub>O-1

M=Ir, Ru

51

E<sub>Ir</sub> = -1216.3248575 (au)

C	2.43154700	-0.56360100	1.31167100
C	2.89981700	-0.90359300	-0.02227200
C	2.02178800	-1.89617400	-0.54375200
C	1.28704100	-1.34597400	1.60549600
C	0.98374200	-2.14516900	0.43017900
Ir	0.79312400	-0.06322500	-0.22948600
C	4.15329500	-0.39733700	-0.65319700
H	5.02264500	-1.00921600	-0.37404700
H	4.08228800	-0.40129300	-1.74625300
H	4.37300100	0.63023400	-0.34018800
C	3.08743900	0.44339500	2.19363900
H	2.47770100	0.66612900	3.07452200
H	4.06604200	0.08860600	2.54310500
H	3.25313300	1.38987100	1.66254200
C	0.49404200	-1.35469100	2.86679300
H	-0.58183400	-1.39033700	2.65931200
H	0.74038600	-2.22744400	3.48602000
H	0.67713000	-0.45612700	3.46460300
C	-0.02872700	-3.23949500	0.36162800
H	-0.47017700	-3.32985900	-0.63702700
H	0.42017500	-4.20773300	0.62330900
H	-0.84964700	-3.06583900	1.06669800
C	2.15519300	-2.60760000	-1.84725500
H	2.63278300	-1.97657200	-2.60385400

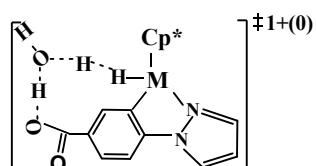
H	2.76128700	-3.51640200	-1.73298600
H	1.17497000	-2.90730000	-2.23344800
C	-0.08953200	4.02763200	-0.30811000
C	1.24748600	4.23365300	-0.57590600
C	1.81673900	2.95294900	-0.60831200
N	0.88610400	2.02966400	-0.36924600
H	-0.91007600	4.72270300	-0.19905200
H	1.74345100	5.18072500	-0.73004800
H	2.83750400	2.64996200	-0.80576100
N	-0.27907700	2.69190800	-0.18589600
C	-1.14068700	0.51201200	0.11204500
C	-1.41805700	1.88863900	0.05829300
C	-2.25378000	-0.30968800	0.28426400
C	-2.69281400	2.43255900	0.18927800
C	-3.55438700	0.19207000	0.31800800
H	-2.11111900	-1.38820600	0.33971500
C	-3.77336500	1.57064800	0.31475300
H	-2.84997400	3.50938900	0.15888600
H	-4.79214800	1.94347800	0.37901100
C	-4.72590600	-0.72913100	0.27612000
O	-5.79727900	-0.46613900	0.76648600
O	-4.52430100	-1.88479300	-0.38016600
H	0.29250900	0.01640900	-1.76311300
H	-3.69294900	-1.87875300	-0.89749000
O	-2.09406800	-1.98010900	-2.08257400
H	-2.25665200	-1.83593300	-3.01912600
H	-1.44023800	-1.30744900	-1.82909400

**E<sub>Ru</sub> = -1206.9469004(au)**

C	2.57587800	-0.49888000	1.16264000
C	2.99006200	-0.87896800	-0.17196100
C	2.09003700	-1.89421200	-0.61783000
C	1.46110800	-1.30677800	1.54103500
C	1.13849200	-2.17146700	0.42851900
C	4.19790700	-0.36931900	-0.88488600
H	5.10816300	-0.94427600	-0.64393300
H	4.06363000	-0.40480200	-1.97296600
H	4.40619500	0.67655800	-0.61933300
C	3.25406000	0.54072000	1.99054400
H	2.64045800	0.82335500	2.85390200
H	4.23060800	0.20060700	2.36890500
H	3.43017600	1.45795900	1.40966600
C	0.74385800	-1.30164000	2.84923800
H	-0.33869600	-1.40559100	2.70158700
H	1.06994000	-2.12159600	3.50833600



H	0.89981700	-0.35726300	3.38427200
C	0.16745600	-3.30470800	0.46869800
H	-0.22929400	-3.54380800	-0.52500400
H	0.62437400	-4.22305200	0.87270600
H	-0.69289200	-3.06885000	1.10899000
C	2.15931600	-2.62239500	-1.92017200
H	2.58907200	-1.98947100	-2.70546900
H	2.77331900	-3.53332800	-1.84379600
H	1.15898100	-2.91788100	-2.25778700
C	-0.02536500	4.00983800	-0.31482000
C	1.31293600	4.21809500	-0.57488200
C	1.88655800	2.93555500	-0.60227800
N	0.96081000	1.99954600	-0.36957400
H	-0.85221900	4.69801800	-0.20468400
H	1.80722800	5.16793600	-0.72671800
H	2.90778000	2.63175300	-0.79811700
N	-0.20621300	2.66731900	-0.19273400
C	-1.03013600	0.48679700	0.17815000
C	-1.33594300	1.86376700	0.06692500
C	-2.16362200	-0.31661700	0.37586600
C	-2.62007500	2.40413700	0.12621500
C	-3.46868100	0.16744600	0.31996500
H	-2.02066600	-1.39113900	0.49643600
C	-3.70551700	1.54587800	0.23909700
H	-2.77979600	3.47877300	0.02955800
H	-4.72944700	1.91139700	0.22127800
C	-4.60626100	-0.77669800	0.19446000
O	-5.73687600	-0.55294300	0.57037600
O	-4.31482700	-1.93448100	-0.43310900
H	0.31918700	-0.05220500	-1.79586100
Ru	0.88536200	-0.08957200	-0.22726700
H	-3.42515200	-1.90578100	-0.84831800
O	-1.74799700	-1.94702200	-2.00379200
H	-1.93293600	-1.33218700	-2.72095900
H	-1.00073200	-1.48975300	-1.55173400



**H<sub>2</sub>O-TS<sub>1-2</sub>**

**M=Ir, Ru**

**51 -1210.96i cm<sup>-1</sup>**

**E<sub>Ir</sub> =-1216.282663(au)**

C	2.27581100	-0.42960600	1.29041500
C	2.87957200	-0.77788400	0.00507200
C	2.12694900	-1.83844300	-0.54575700
C	1.21430600	-1.36308500	1.55311200
C	1.06020000	-2.18840700	0.38618200
Ir	0.70818200	-0.10462800	-0.19912700
C	4.08816700	-0.13124300	-0.58034200
H	5.00407000	-0.64865400	-0.26554400
H	4.06227800	-0.13930600	-1.67540800
H	4.18350600	0.91104200	-0.25447100
C	2.79905100	0.60902900	2.22210800
H	2.06275600	0.85799100	2.99223900
H	3.71184800	0.26485300	2.72546300
H	3.04083900	1.53686100	1.69068200
C	0.39383300	-1.44316900	2.79183400
H	-0.64933600	-1.69007200	2.57009500
H	0.78898800	-2.21797600	3.46088700
H	0.39211100	-0.49271200	3.33343500
C	0.12357200	-3.33785900	0.21547600
H	-0.43824100	-3.26464900	-0.72296000
H	0.67298600	-4.28847500	0.22528700
H	-0.61209600	-3.37441500	1.02491400
C	2.34336100	-2.52733100	-1.84824800
H	2.92212600	-1.91355900	-2.54547100
H	2.88634000	-3.46964100	-1.69712500
H	1.38741400	-2.77413000	-2.32321000
C	-0.08284500	4.01517000	-0.25104100
C	1.20796500	4.18397700	-0.72125300
C	1.72449700	2.89033900	-0.83900200
N	0.80691500	1.99538900	-0.46297000
H	-0.85655300	4.73141900	-0.01171100
H	1.70386900	5.11625700	-0.94803600
H	2.69489000	2.55302100	-1.18245800
N	-0.29486900	2.69194900	-0.10337100
C	-1.12834000	0.55506800	0.43388300
C	-1.41818400	1.91221100	0.27869300
C	-2.19589300	-0.31006000	0.59168600
C	-2.72072700	2.40943400	0.31600900
C	-3.50680900	0.12571800	0.43718400
H	-2.02571000	-1.38450900	0.63113500
C	-3.76884100	1.49655100	0.38487500
H	-2.91968100	3.47414300	0.19966500
H	-4.80438800	1.82147200	0.30981500
C	-4.54770100	-0.90874000	0.02953500

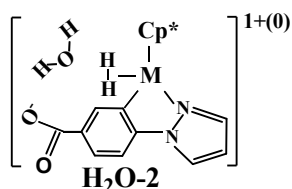
O	-5.72206500	-0.73234300	0.33502500
O	-4.03808500	-1.85388800	-0.67485800
H	-0.02862800	-0.10193900	-1.79186200
H	-2.78904000	-1.70640900	-1.32227300
O	-1.85589700	-1.65173200	-1.86936400
H	-2.10769900	-1.61213700	-2.79656900
H	-0.67625000	-0.68981400	-1.55830700

**-736.41i cm<sup>-1</sup>**

**E<sub>Ru</sub> = -1206.918334(au)**

C	2.63802300	-0.43904900	0.97374200
C	2.89947000	-1.00107800	-0.33670400
C	1.91260800	-2.00908500	-0.55461600
C	1.55106200	-1.15859600	1.57591600
C	1.08209700	-2.13179300	0.62044100
C	4.03791600	-0.64246200	-1.23099800
H	4.95403800	-1.20787800	-0.99291100
H	3.79653600	-0.83515500	-2.28327000
H	4.29165700	0.42249200	-1.14940700
C	3.43340700	0.65294100	1.60617100
H	2.85768600	1.15629500	2.39175500
H	4.36712000	0.28064300	2.05423100
H	3.70469200	1.42096800	0.86927000
C	1.01141700	-0.96869000	2.95359000
H	-0.07809200	-1.09039000	2.96969000
H	1.44283500	-1.68944000	3.66453300
H	1.22346500	0.04006800	3.32710800
C	0.02975900	-3.17025200	0.82645000
H	-0.61623900	-3.25560800	-0.05661900
H	0.46585500	-4.15992900	1.03484900
H	-0.61961700	-2.91495300	1.67265500
C	1.75204600	-2.85583400	-1.77418400
H	2.20108900	-2.38015600	-2.65425100
H	2.22328500	-3.84155600	-1.64359600
H	0.68882900	-3.01475600	-1.99013600
C	0.02721400	4.01149300	-0.25560900
C	1.31534200	4.18927500	-0.72437500
C	1.83651100	2.89230700	-0.84501700
N	0.93174500	1.98234100	-0.47274300
H	-0.75419600	4.71769600	-0.00966200
H	1.80771800	5.12610900	-0.94548400
H	2.80999200	2.56552400	-1.19136500
N	-0.17025900	2.68015300	-0.11435100
C	-0.99912500	0.54521200	0.45134800
C	-1.29568500	1.90224700	0.26780200

C	-2.10918500	-0.28468500	0.60650400
C	-2.59045000	2.42557400	0.25430600
C	-3.40852100	0.16385200	0.40452500
H	-1.95264800	-1.35832900	0.69179100
C	-3.65852200	1.53753700	0.30781200
H	-2.76457700	3.49210600	0.10318000
H	-4.68574700	1.87837200	0.19472400
C	-4.46238900	-0.84069000	0.02470500
O	-5.64133900	-0.67410300	0.31596900
O	-4.00024700	-1.83882000	-0.67612600
H	-0.05800200	-0.23489200	-1.74442600
Ru	0.83170000	-0.14012100	-0.20433200
H	-2.92053800	-1.74950600	-1.15014700
O	-1.80870700	-1.75803800	-1.73298300
H	-1.99352600	-1.72339900	-2.67599600
H	-0.73244700	-0.85815100	-1.55199600



**M=Ir, Ru**

**51**

**E<sub>Ir</sub> = -1216.3011679(au)**

C	2.22307000	-0.41961600	1.34101200
C	2.87644500	-0.86652800	0.11303900
C	2.09333800	-1.92072200	-0.41489300
C	1.11075400	-1.29036000	1.60715800
C	0.97224400	-2.17291200	0.48242600
Ir	0.75235000	-0.10805600	-0.25425300
C	4.15731800	-0.33733100	-0.43592100
H	5.01222200	-0.92574100	-0.07744400
H	4.17203600	-0.36551200	-1.53076700
H	4.33066100	0.69820500	-0.12460900
C	2.73111000	0.66022500	2.23291700
H	1.93858500	1.04537400	2.88194600
H	3.54444600	0.29342900	2.87186600
H	3.11701800	1.50624000	1.65296700
C	0.22922000	-1.26346100	2.80502600
H	-0.82050900	-1.42202700	2.53740200
H	0.52365100	-2.05384700	3.50701500
H	0.29062500	-0.30482200	3.32826100
C	-0.01448400	-3.28413400	0.33264300
H	-0.61400100	-3.17858800	-0.58152900

H	0.50087500	-4.25297500	0.30934400
H	-0.71352800	-3.30556700	1.17417300
C	2.33184000	-2.68724400	-1.66905500
H	2.95959800	-2.13263400	-2.37342100
H	2.83279100	-3.63815100	-1.44558200
H	1.38419200	-2.92491300	-2.16523000
C	-0.00262300	4.01855700	-0.29620600
C	1.30744600	4.18360400	-0.71303600
C	1.82204100	2.88979400	-0.81802100
N	0.88490200	1.99623700	-0.48338600
H	-0.78361300	4.73648300	-0.08740400
H	1.81623700	5.11467600	-0.91458600
H	2.80422600	2.55432500	-1.12695800
N	-0.22792200	2.69670500	-0.16483300
C	-1.12126900	0.55966100	0.27418400
C	-1.37282100	1.92810500	0.17092200
C	-2.20314100	-0.28644900	0.42535900
C	-2.65995400	2.45724300	0.26157300
C	-3.50800600	0.19178400	0.37495300
H	-2.07273000	-1.36616200	0.43036900
C	-3.72757100	1.57093200	0.36208000
H	-2.83117700	3.53087200	0.18916700
H	-4.75840100	1.91885600	0.36523600
C	-4.63419200	-0.81640100	0.10750300
O	-5.77600700	-0.47524900	0.42444500
O	-4.22176400	-1.86931000	-0.46691700
H	0.23475000	-0.05721900	-1.93790100
H	-2.78804000	-1.87676100	-1.42113800
O	-1.95572100	-1.91571600	-1.97971500
H	-2.27343300	-2.16148700	-2.85172900
H	-0.37291700	-0.56861300	-1.57897000

**E<sub>Ru</sub> = -1206.9713186(au)**

C	2.75941000	-0.80551700	0.71140600
C	2.51927200	-1.83235100	-0.23690200
C	1.18288000	-2.34875200	-0.01831100
C	1.56419700	-0.66696100	1.52932700
C	0.62546900	-1.67039500	1.10746800
C	3.47304900	-2.35260400	-1.26069800
H	3.98077800	-3.26466800	-0.91278500
H	2.95339100	-2.60580700	-2.19227100
H	4.24389300	-1.61326300	-1.50791900
C	4.02418100	-0.03915900	0.90548700
H	3.82143000	1.01065100	1.15122600
H	4.62633900	-0.45493800	1.72685500

H	4.64286900	-0.05305900	-0.00063700
C	1.39834200	0.25783800	2.68882900
H	0.34044600	0.50606600	2.83399800
H	1.77564400	-0.17456000	3.62782500
H	1.93085700	1.20272900	2.51930200
C	-0.66769900	-1.98877700	1.77661800
H	-1.35782500	-2.52339600	1.11315700
H	-0.48150200	-2.62344200	2.65539100
H	-1.18059100	-1.08371200	2.11960400
C	0.56935500	-3.49854000	-0.74665200
H	0.82726700	-3.47292000	-1.81308100
H	0.92765300	-4.45956300	-0.34739200
H	-0.52438900	-3.48664300	-0.66015600
C	0.65399000	3.98264700	-0.18018700
C	2.01876100	4.04550400	-0.40204000
C	2.41070500	2.71723300	-0.60861100
N	1.35771100	1.89976900	-0.51494400
H	-0.07601900	4.75572100	0.01500600
H	2.63828000	4.93118100	-0.41666500
H	3.38716000	2.30053800	-0.82269500
N	0.28994000	2.68349300	-0.25412300
C	-0.90133800	0.63322500	-0.34170300
C	-0.96408200	2.02144100	-0.15897400
C	-2.13368900	-0.03021900	-0.30312800
C	-2.14601000	2.72457500	0.07800800
C	-3.33976800	0.62510100	-0.05307500
H	-2.16990500	-1.10734200	-0.45572400
C	-3.33316600	2.01169600	0.13568800
H	-2.13973900	3.80717100	0.21590100
H	-4.29181400	2.49133800	0.31972200
C	-4.67418700	-0.13837200	0.02875600
O	-5.68733900	0.56476800	0.18270300
O	-4.60705500	-1.39489500	-0.06246300
H	1.19581800	-0.07992500	-2.24449000
Ru	1.00800200	-0.18793500	-0.50878500
H	-3.50008500	-2.66064800	-0.22337600
O	-2.86440800	-3.36360700	-0.52708600
H	-2.79052000	-3.14683900	-1.46011700
H	0.36731200	-0.34415500	-2.12372300