

Electronic Supplementary Information

Synthesis and configuration of the nonadecenetriol isolated from seeds of *Persea Americana*

Xin Yan,^{a,b} Shao-Min Zhang,^a Yikang Wu*^a and Po Gao*^b

^aState Key Laboratory of Bioorganic and Natural Products Chemistry, Shanghai Institute of Organic Chemistry, Chinese Academy of Sciences, 345 Lingling Road, Shanghai 200032, China

^bSchool of Chemistry and Materials, Heilongjiang University, Harbin 150080, China.

e-mail: yikangwu@sioc.ac.cn

Table of Contents

¹ H NMR, ¹³ C NMR and FT-IR for 2	S 2
¹ H NMR, ¹³ C NMR and FT-IR for 3	S 5
¹ H NMR, ¹³ C NMR and FT-IR for 7a	S 8
¹ H NMR, ¹³ C NMR and FT-IR for 7a'	S 11
¹ H NMR, ¹³ C NMR and FT-IR for 8	S 14
¹ H NMR, ¹³ C NMR and FT-IR for 9	S 17
¹ H NMR, ¹³ C NMR and FT-IR for 11	S 20
¹ H NMR, ¹³ C NMR and FT-IR for 12	S 23
¹ H NMR, ¹³ C NMR and FT-IR for 13	S 26
¹ H NMR, ¹³ C NMR and FT-IR for 13'	S 29
¹ H NMR, ¹³ C NMR and FT-IR for 14	S 32
¹ H NMR, ¹³ C NMR and FT-IR for 14'	S 35
¹ H NMR, ¹³ C NMR and FT-IR for 15	S 38
¹ H NMR, ¹³ C NMR and FT-IR for 16	S 41
¹ H NMR, ¹³ C NMR and FT-IR for 17	S 44
¹ H NMR and FT-IR for 17'	S 47
¹ H NMR, ¹³ C NMR and FT-IR for 18	S 49
¹ H NMR, ¹³ C NMR and FT-IR for 19	S 52
¹ H NMR, ¹³ C NMR and FT-IR for 20	S 55
¹ H NMR, ¹³ C NMR and FT-IR for 21	S 58
¹ H NMR, ¹³ C NMR and FT-IR for 22	S 61
¹ H NMR, ¹³ C NMR and FT-IR for 23	S 64
¹ H NMR, ¹³ C NMR and FT-IR for 24	S 67
¹ H NMR, ¹³ C NMR and FT-IR for (2 <i>S</i> ,4 <i>R</i>)- 1	S 70
¹ H NMR, ¹³ C NMR and FT-IR for (2 <i>S</i> ,4 <i>S</i>)- 1	S 73
¹ H NMR, ¹³ C NMR and FT-IR for (2 <i>R</i> ,4 <i>R</i>)- 1	S 76
Tabular NMR data comparison between nat- 1 and (2 <i>R</i> ,4 <i>R</i>)- 1	S 80

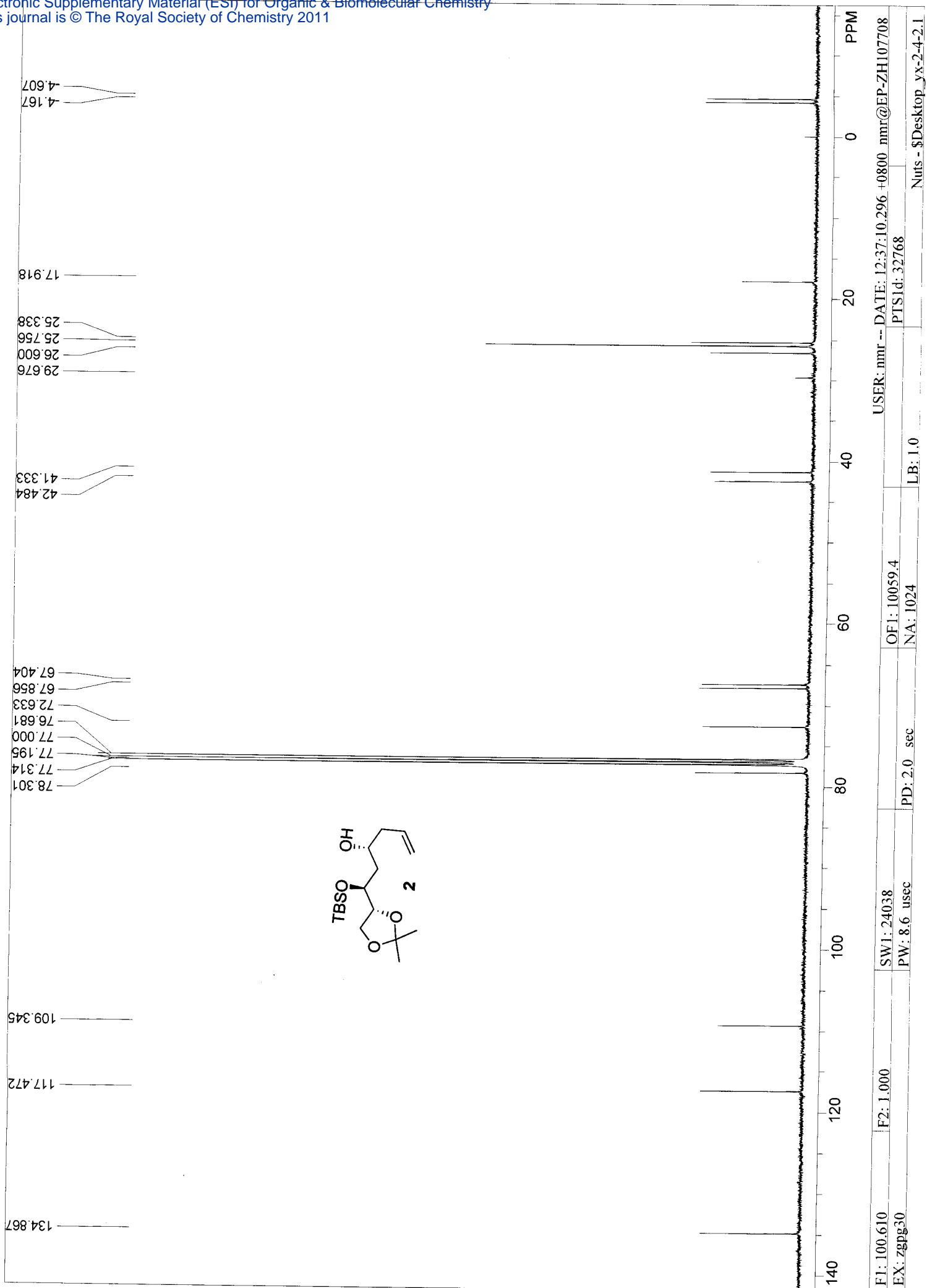

S 2

100 MHz, CDCl₃

F1: 100.610	F2: 1.000	SW1: 24038	OF1: 10059.4	USER: nmr -- DATE: 12:37:10,296 +0800 nmr@EP-ZH107708
EX: zgpg30		PW: 8.6 usec	NA: 1024	PTSId: 32768
		PD: 2.0 sec	LB: 1.0	Nuts - \$Desktop_yx-2-4-2.1

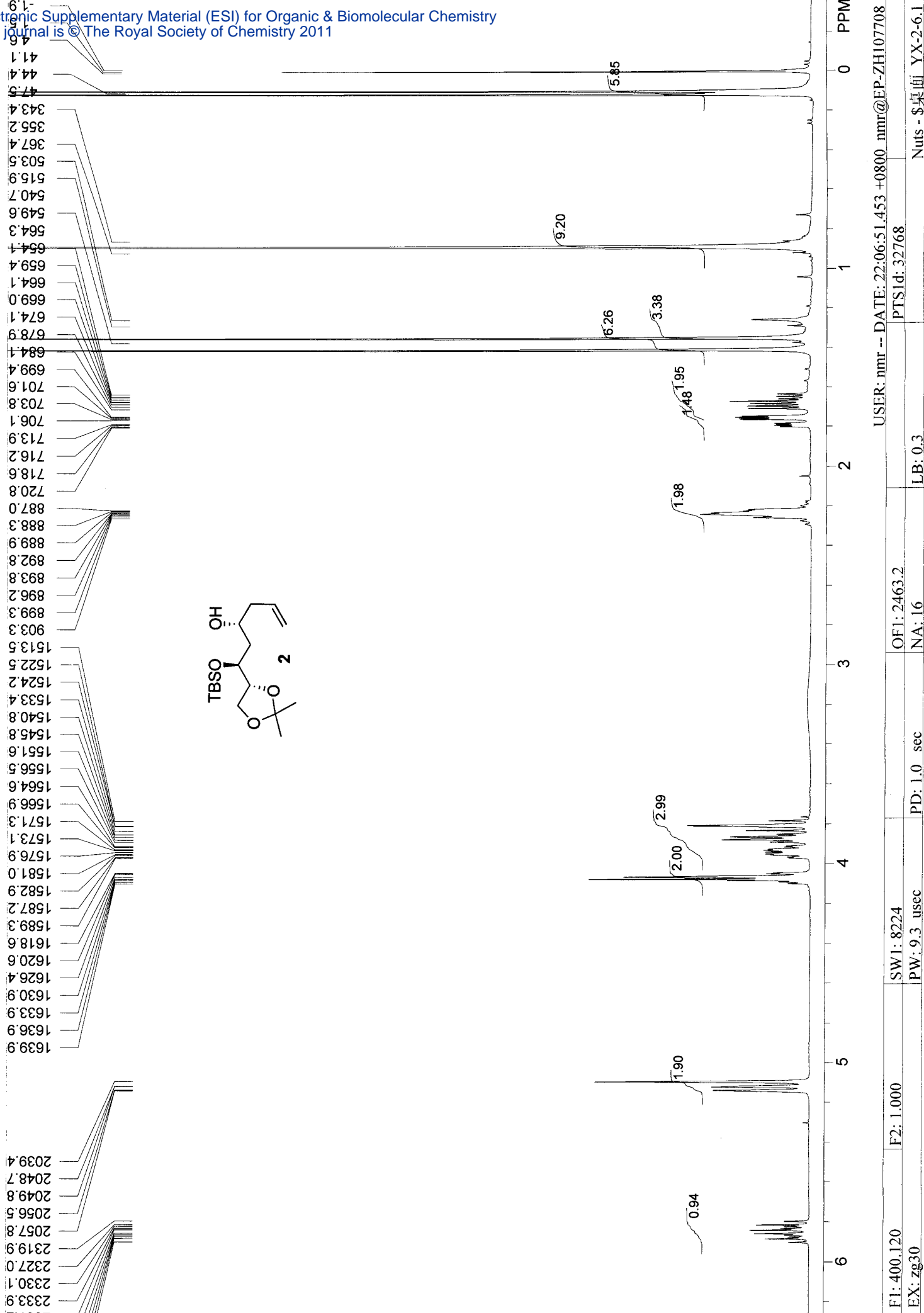

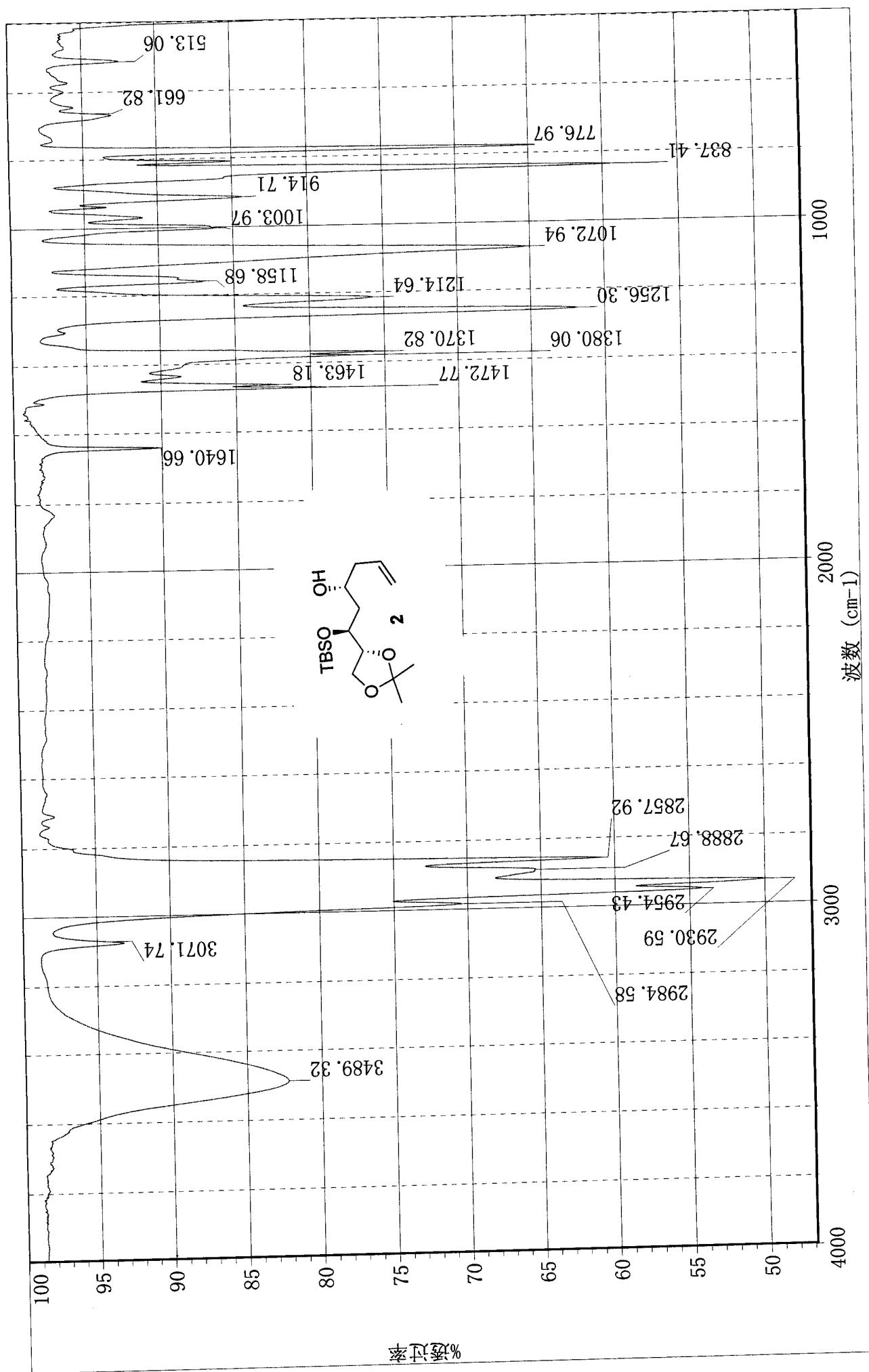

**yx-2-13

采集时间: 星期一 2月 21 10:16:39 2011 (GMT+08:00)

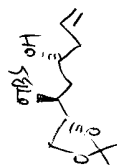

上海有机所生命有机化学国家重点实验室

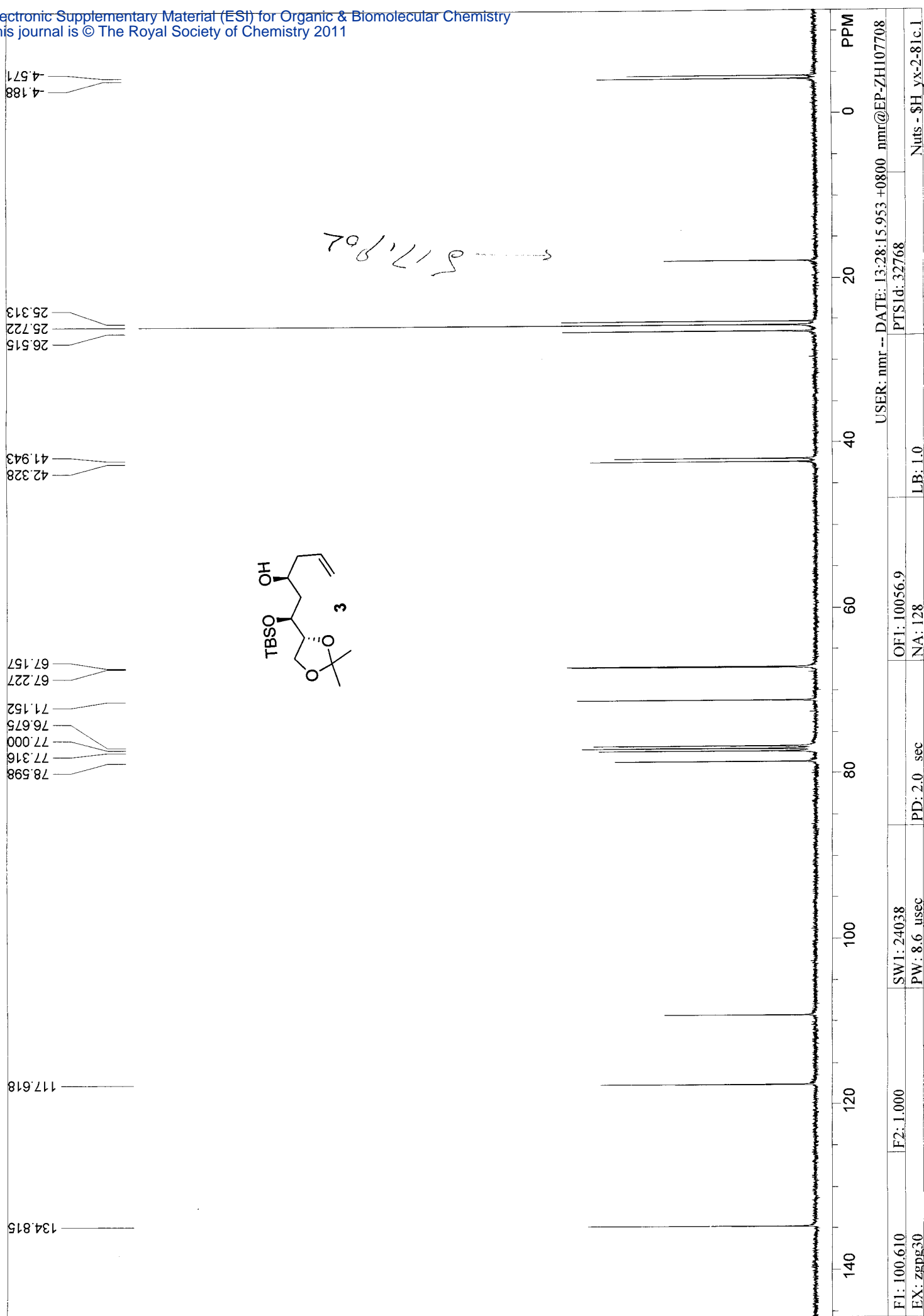

S 5

100 MHz, CDCl₃

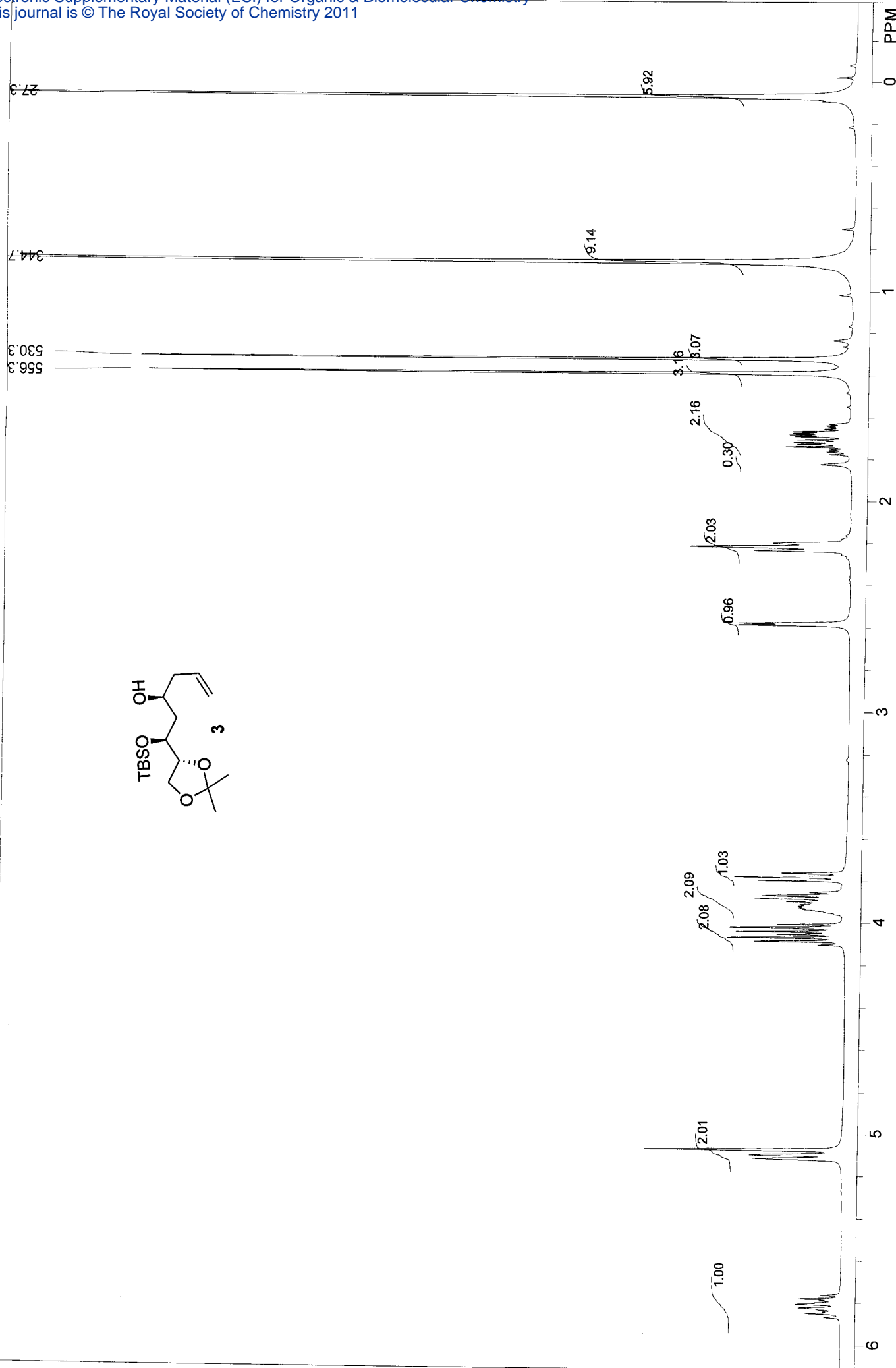
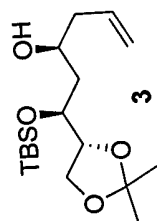

USER: nmr -- DATE: 13:18:49.781 +0800 nmr@EP-ZH107708
PTSID: 32768
OFI: 2460.6
NA: 16
LB: 0.3
PD: 1.0 sec
SW1: 8224
PW: 9.3 usec
F1: 400.120
F2: 1.000
EX: zg30
Nuts - \$H_yx-2-81.1

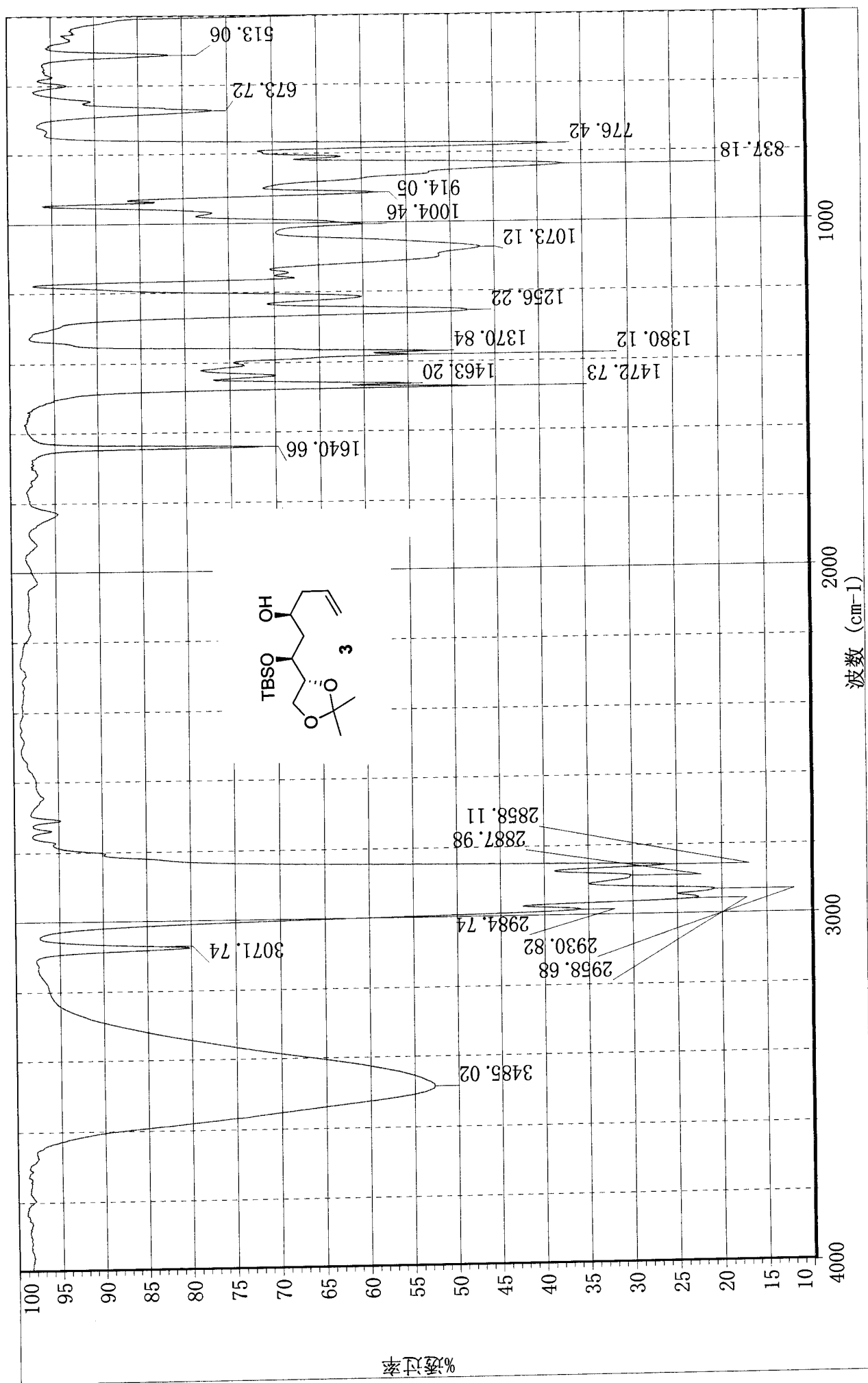

**yx-2-81-2

采集时间: 星期一 2月 21 10:29:53 2011 (GMT+08:00)

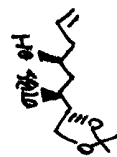

上海有机所生命有机化学国家重点实验室

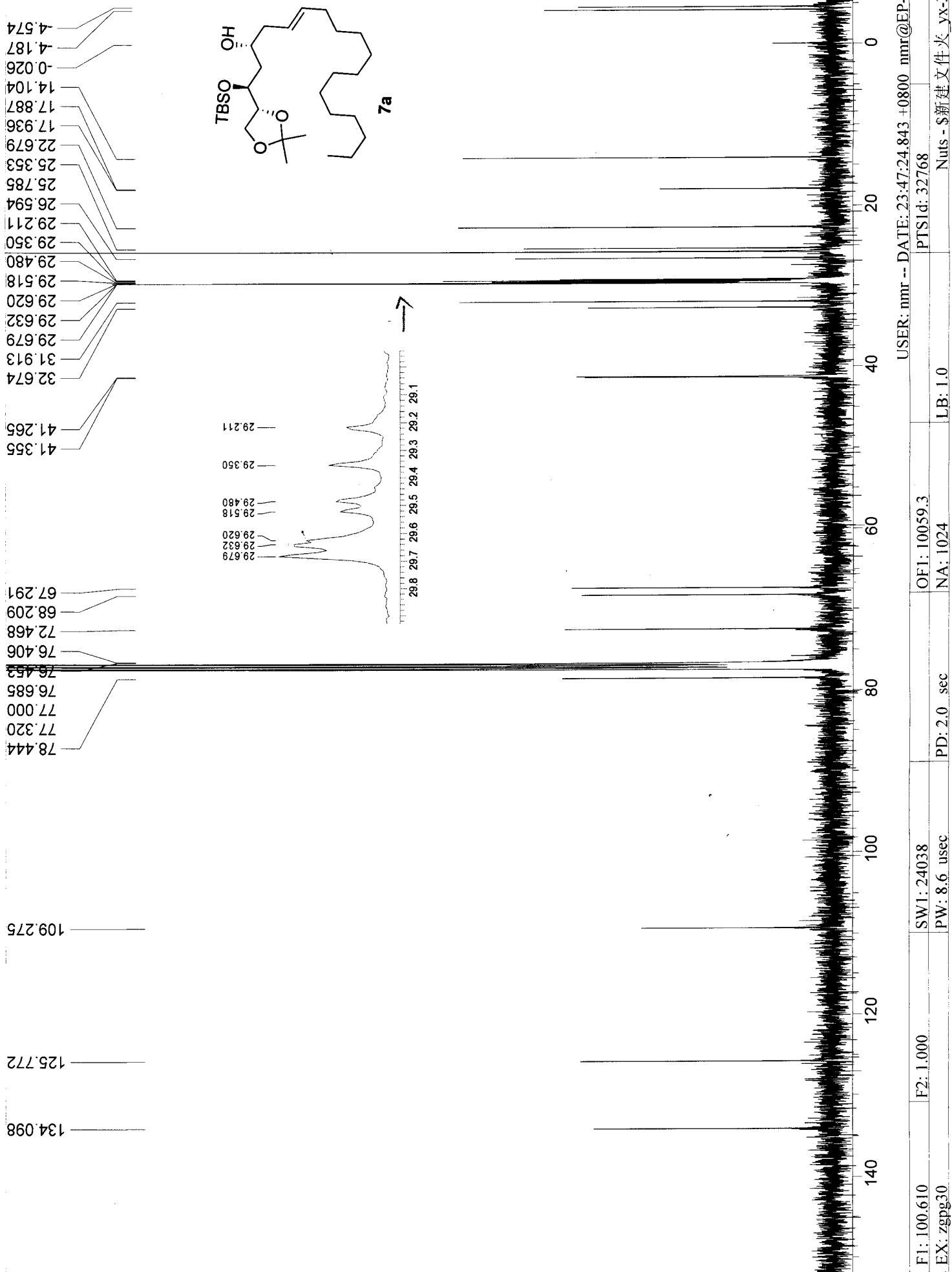

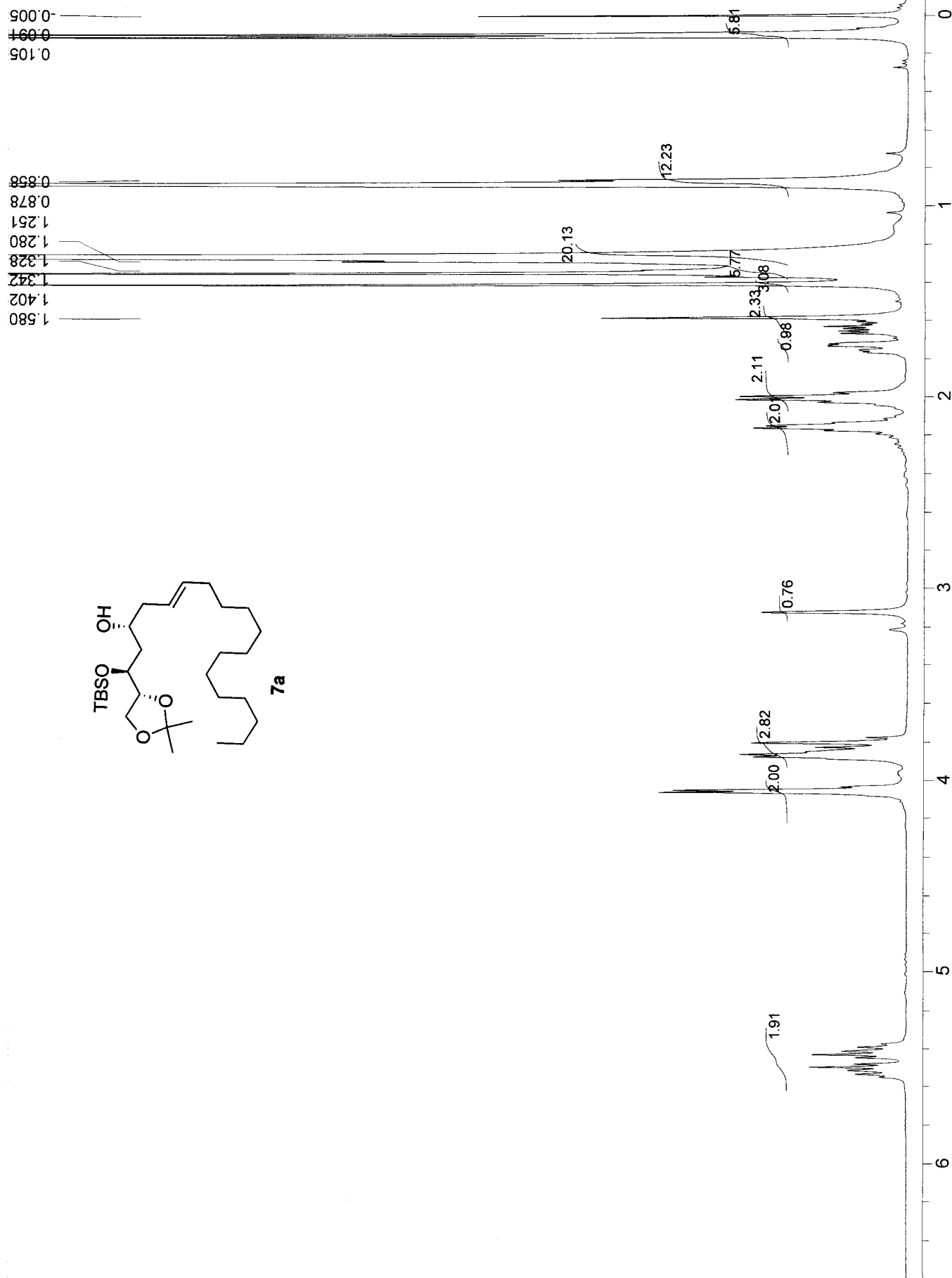

USER: nmr -- DATE: 18:19:42.375 +0800 nmr@EP-ZH107708
PTSId: 32768
OF1: 2460.6
NA: 16
PD: 1.0 sec
SW1: 8224
F2: 1.000
EX: zg30
PW: 9.3 usec
LB: 0.3
Nuts - \$新建文件火_yx-3-28-up.1

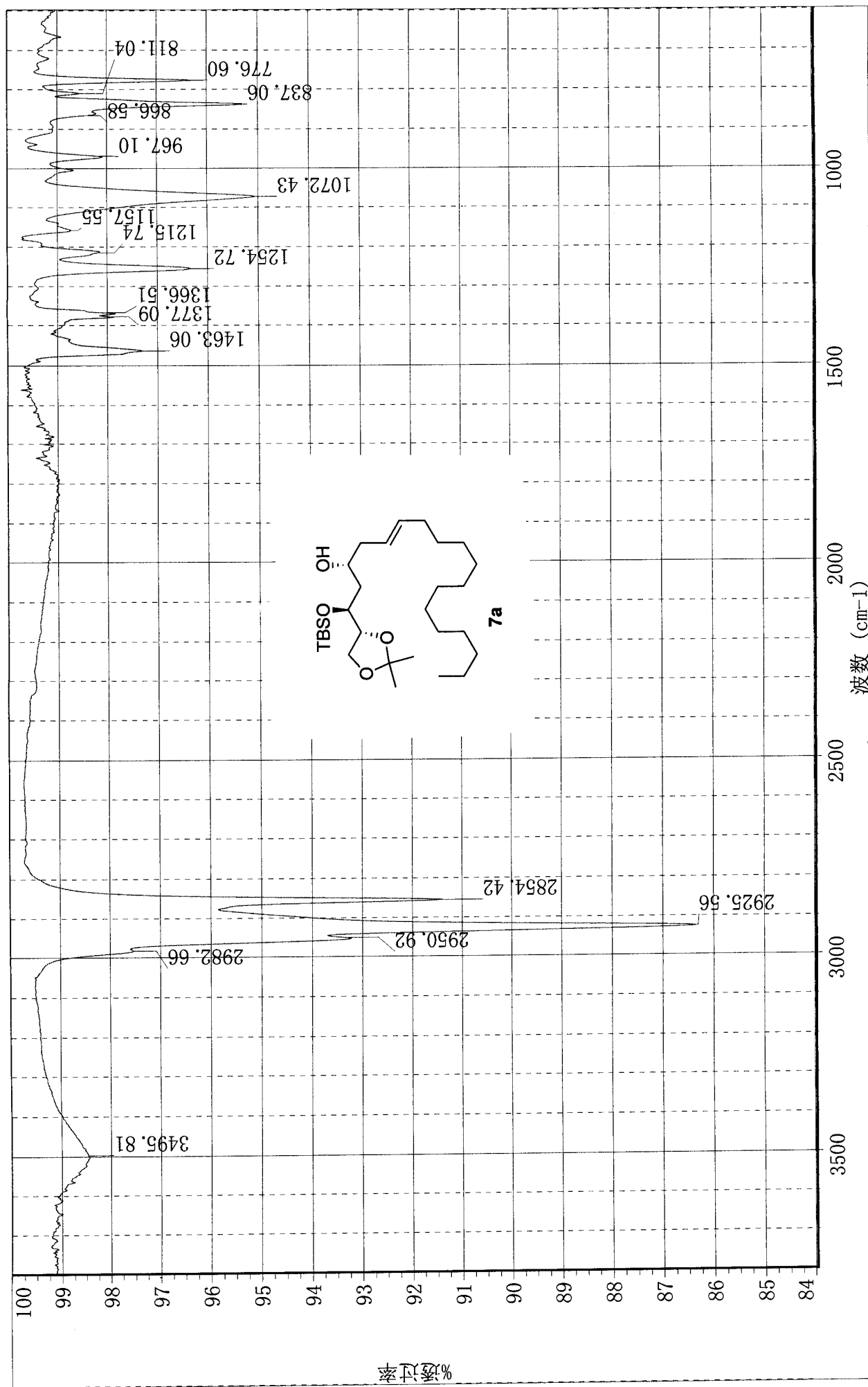

***yx-3-28-up

采集时间: 星期六 12月 18 13:47:00 2010 (GMT+08:00)

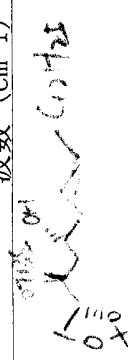

上海有机所生命有机化学国家重点实验室

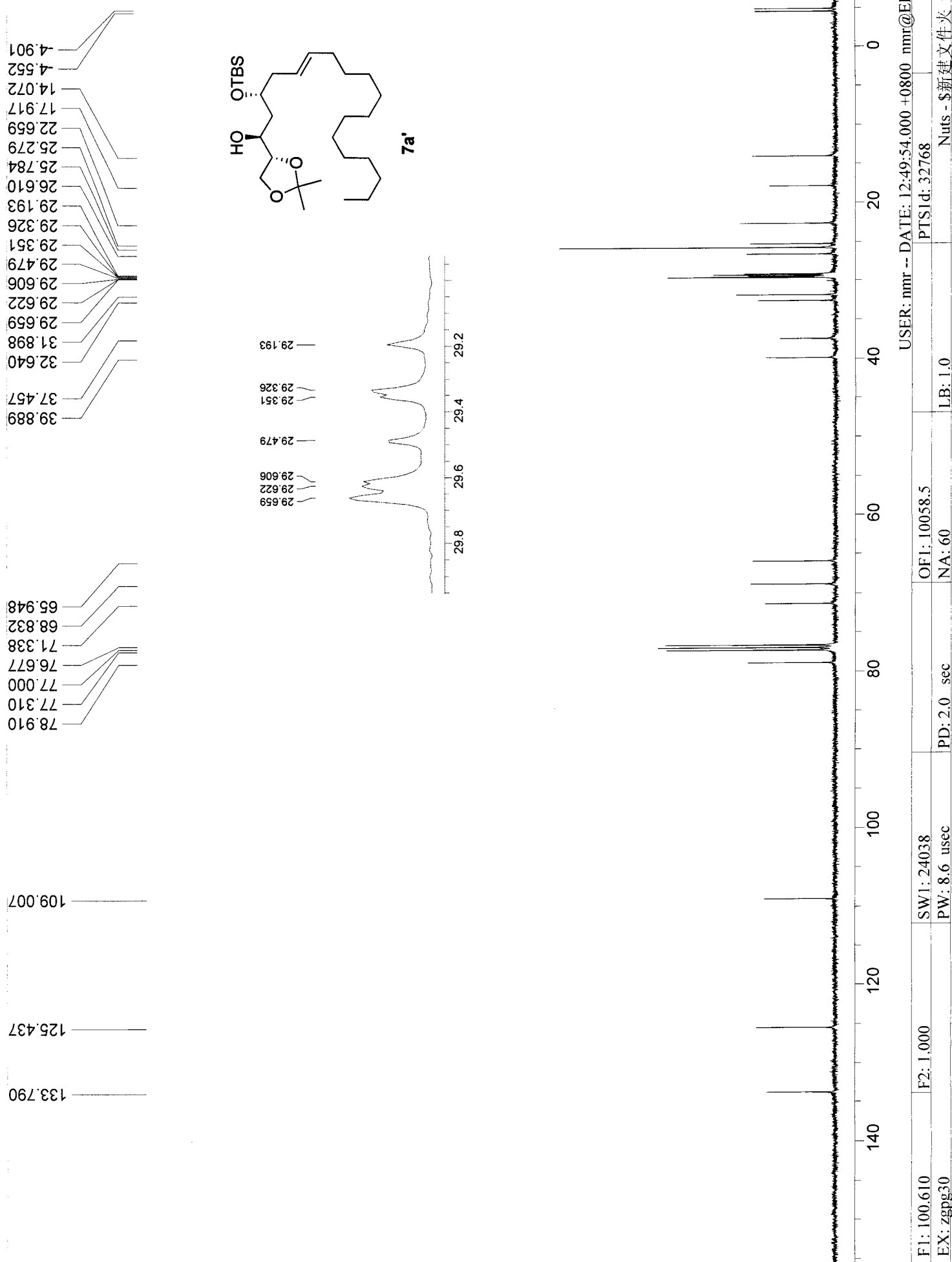

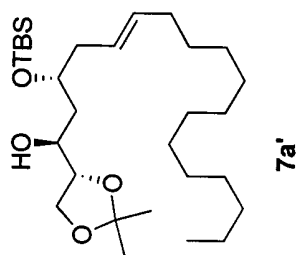

7a'

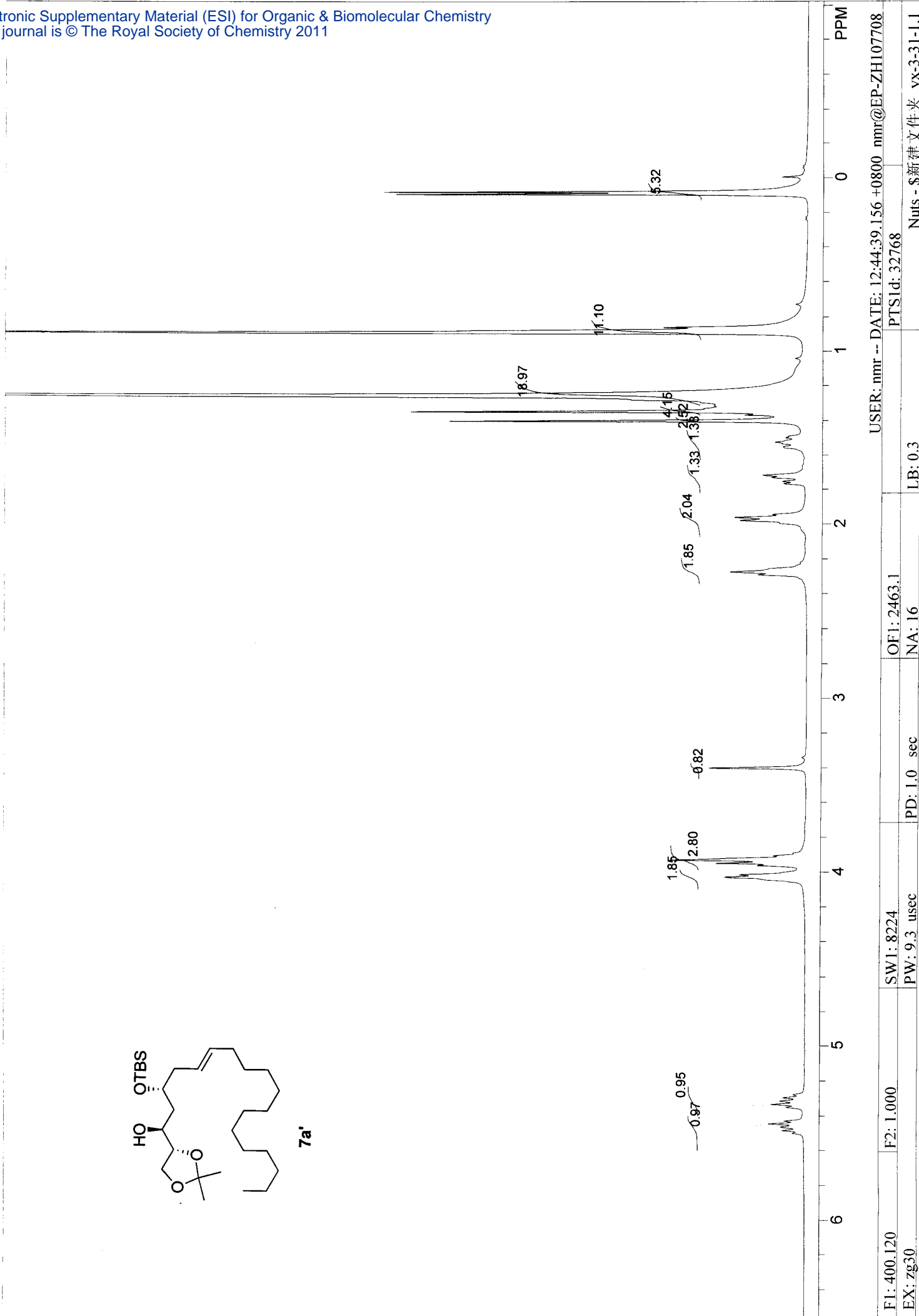

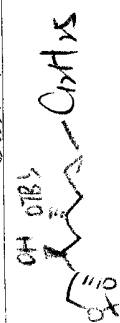
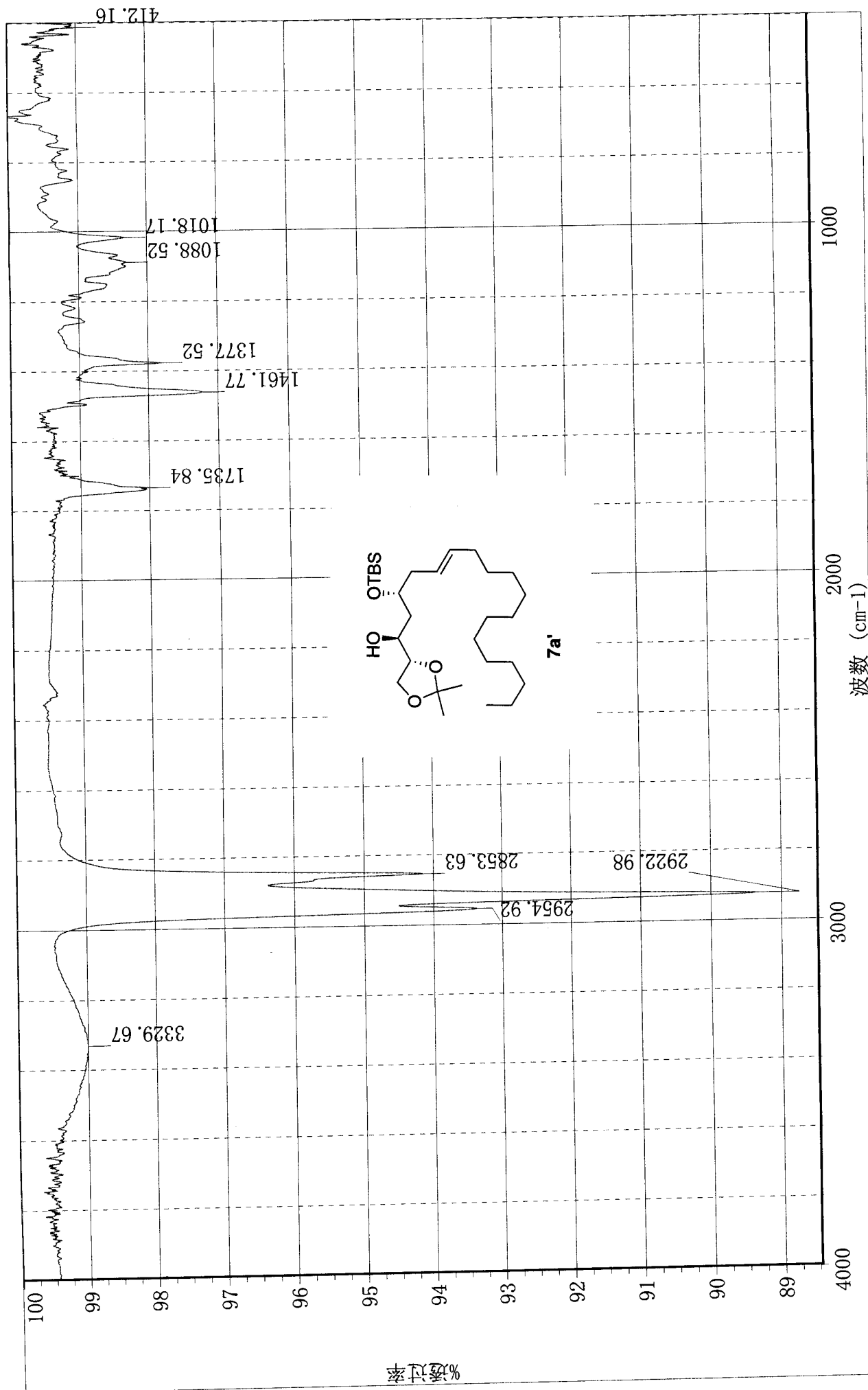

*yx-3-29-1

采集时间: 星期三 1月 12 20:48:18 2011 (GMT+08:00)

Conflys

上海有机所生命有机化学国家重点实验室

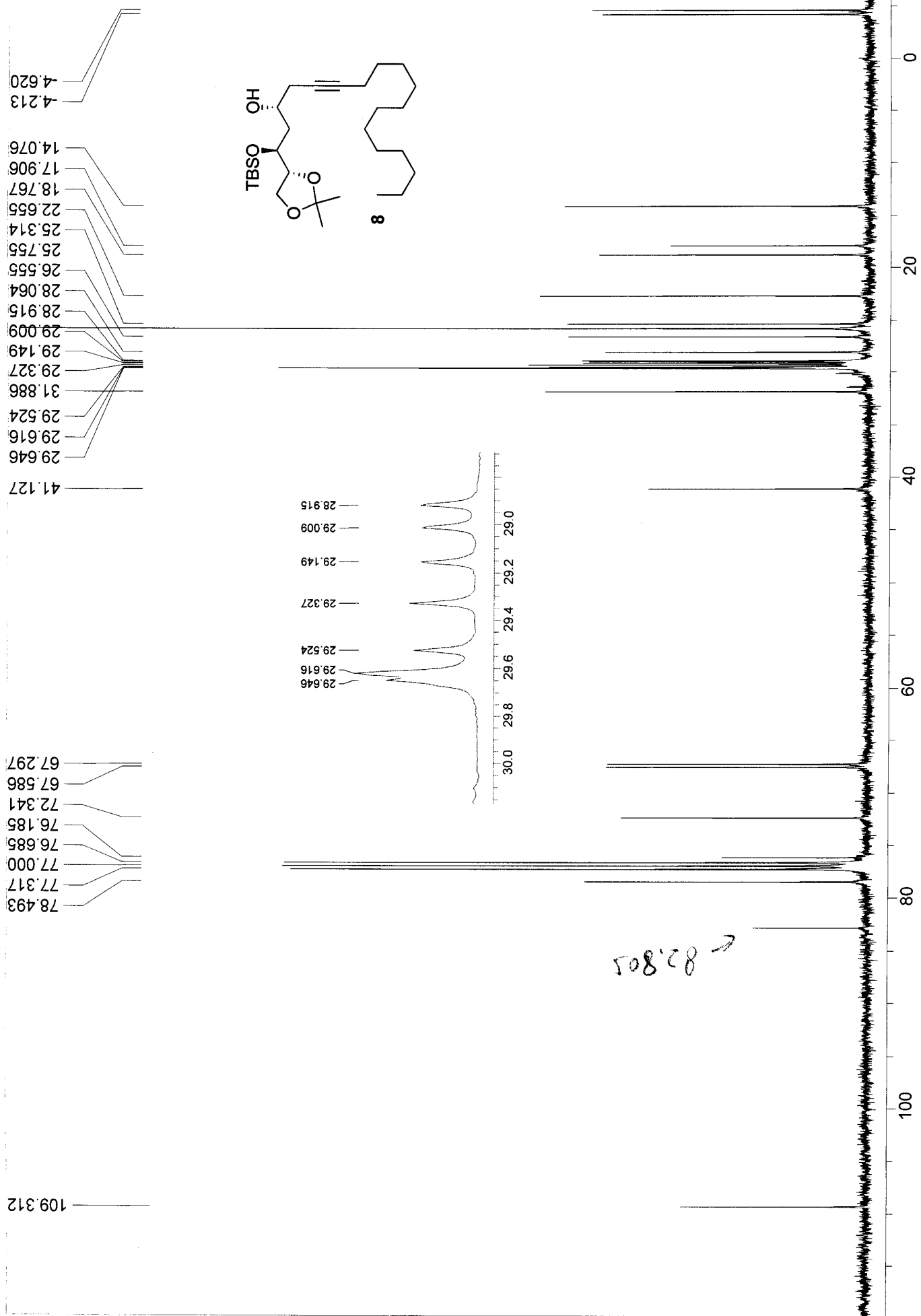

USER: nmr -- DATE: 15:07:55.765 +0800 nmr@EP-ZH107708
PTSID: 32768
OF1: 10058.1
NA: 256
PD: 2.0 sec
SW1: 24038
PW: 8.6 usec
F1: 100.610
F2: 1.000
EX: zgpg30
LB: 1.0
Nuts - \$ yx-3-4-2-2c.1

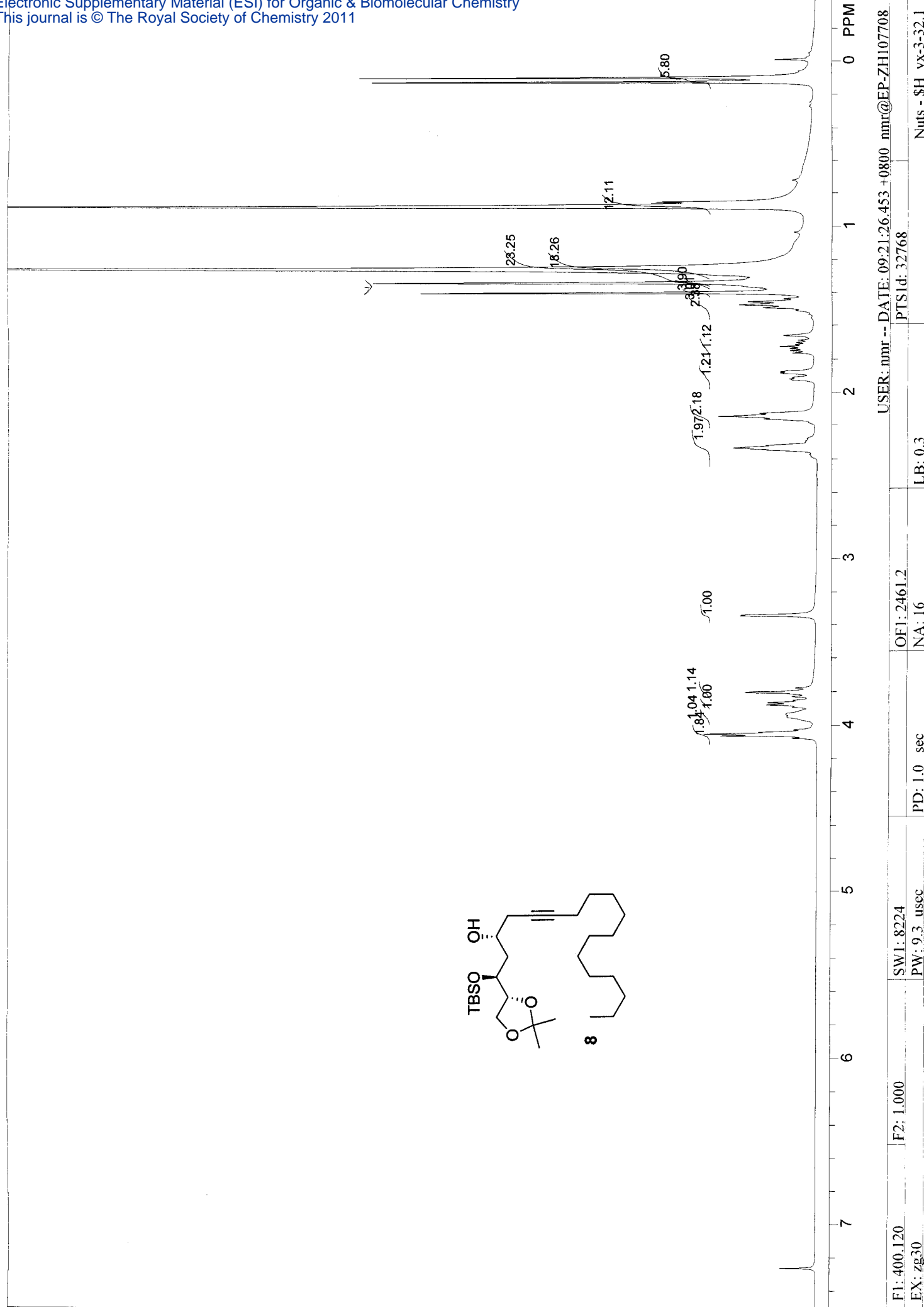

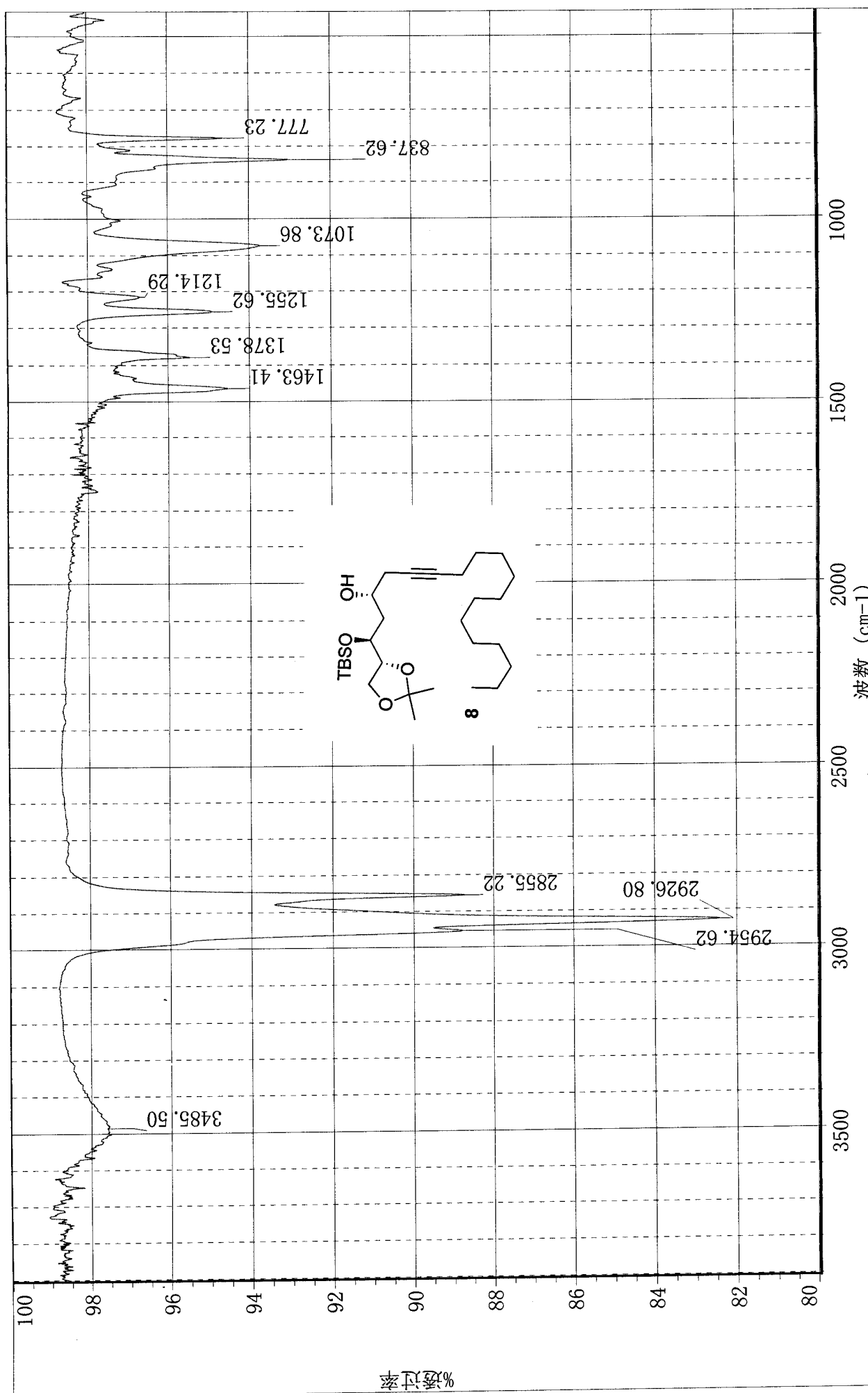

yx-3-25

采集时间: 星期二 12月 14 15:11:41 2010 (GMT+08:00)

2010.12.14 15:11:41

上海有机所生命有机化学国家重点实验室

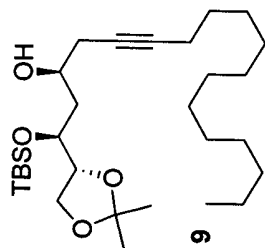

100 MHz, CDCl₃

S 17

F1: 100.610	F2: 1.000	SWH: 24038	PD: 2.0 sec	OF1: 10053.0	LB: 1.0	USER: mmr -- DATE: 10:47:21.625 +0800_nmr@EP-ZH107708
EX: zgpg30		PW: 8.6 usec	NA: 128	PTSId: 32768		Nuts - \$新建文件火_yx-3-44c.1

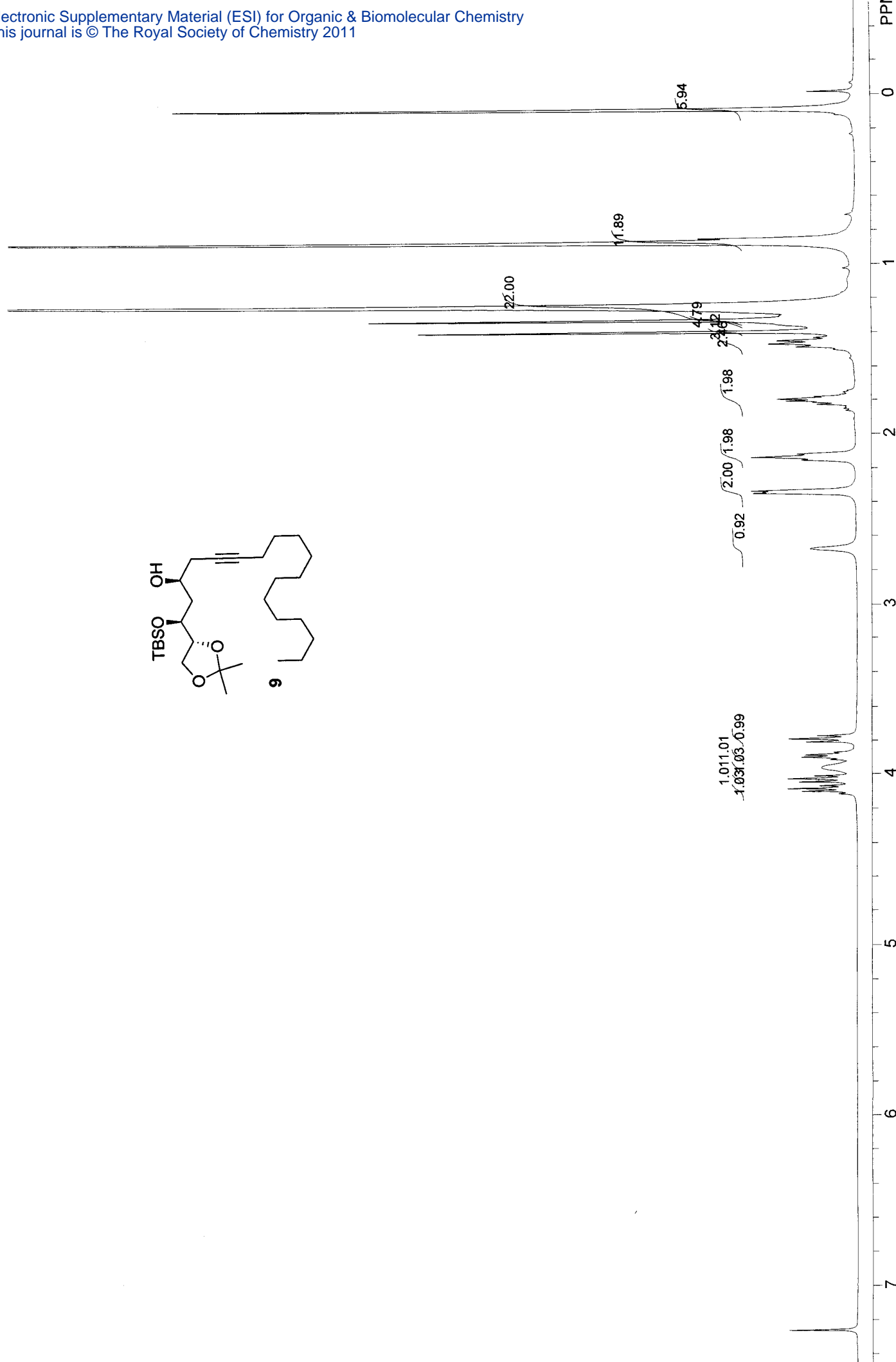
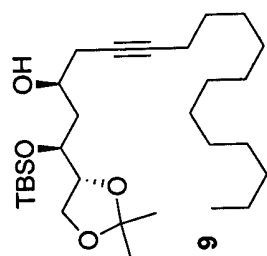

USER: nmr -- DATE: 16:53:53.468 +0800 nmr@EP-ZHI07708
PTSD: 32768

OF1: 2461.1

SW1: 8224

F2: 1.000

I: 400.120

YX-3-644

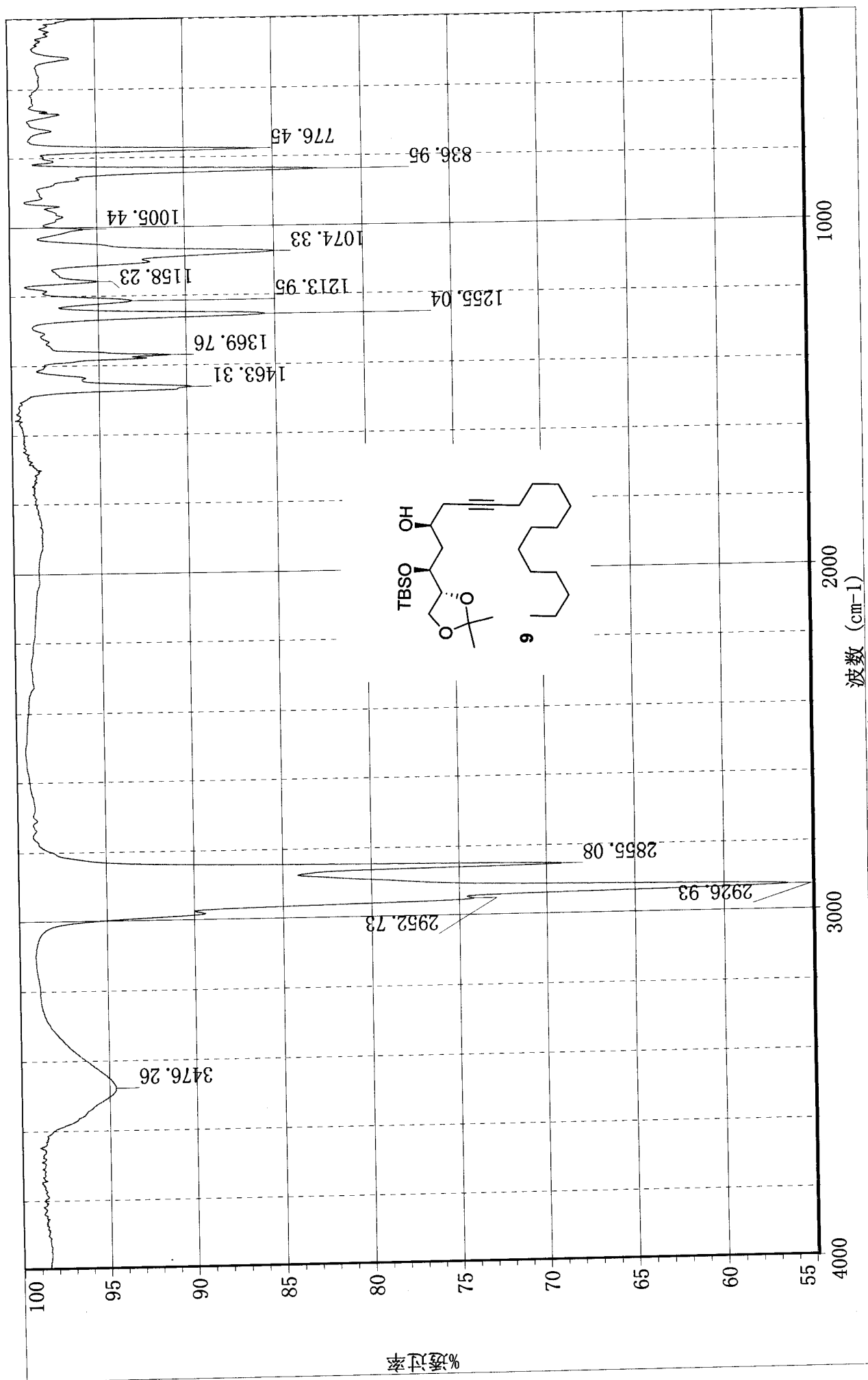

***yx-3-44

采集时间: 星期四 4月 07 21:42:31 2011 (GMT+08:00)

上海有机所生命有机化学国家重点实验室



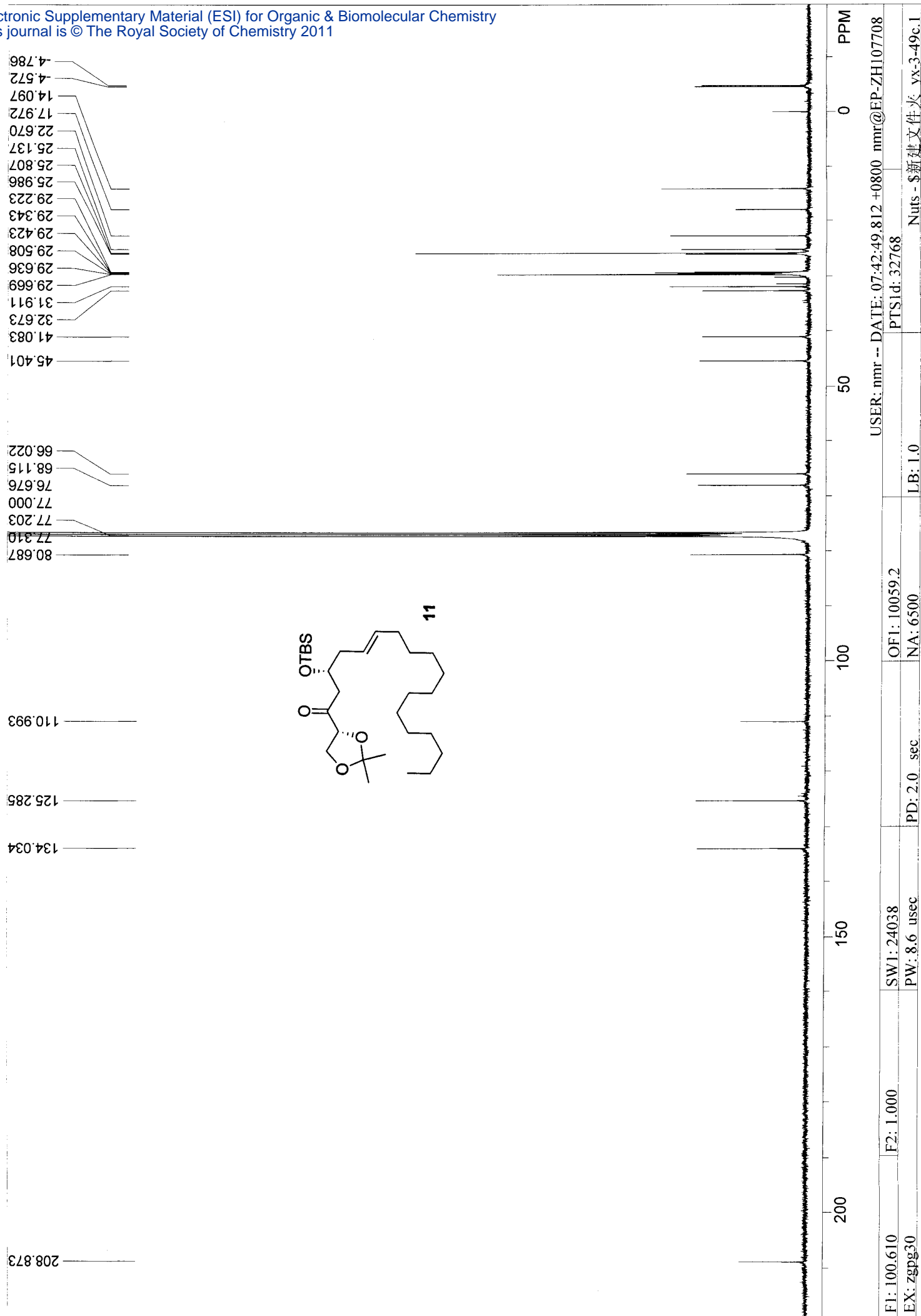

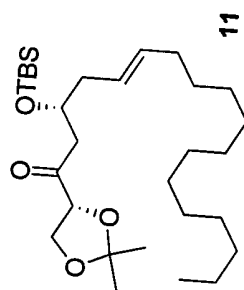

11

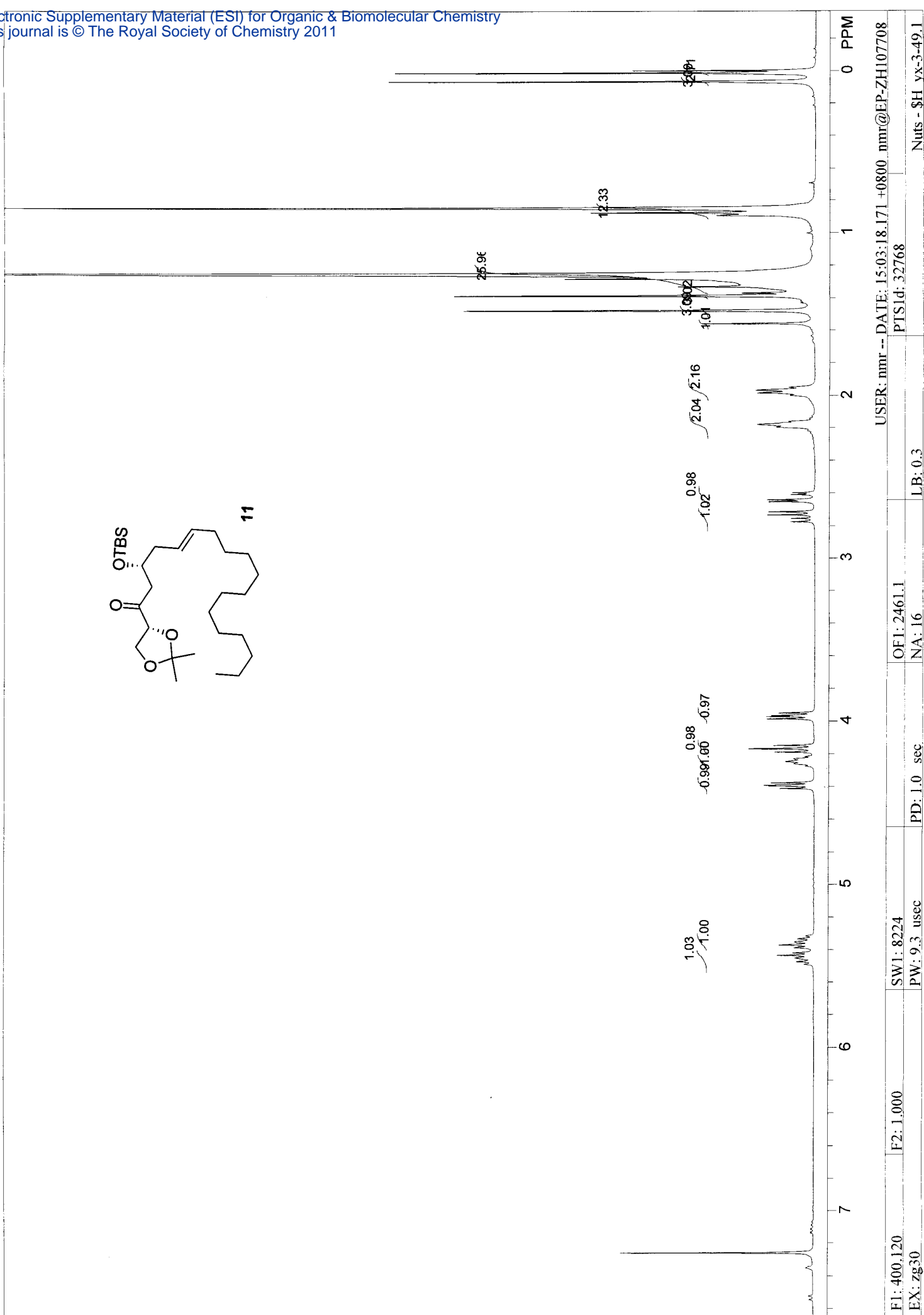

USER: nmr -- DATE: 15:03:18.171 +0800 nmr@EP-ZH107708

PTSID: 32768

OF1: 2461.1

NA: 16

PD: 1.0 sec

SW1: 8224

PW: 9.3 usec

F2: 1,000

F1: 400,120

EX: zg30

LB: 0.3

Nuts - \$H_yx-3-49.1

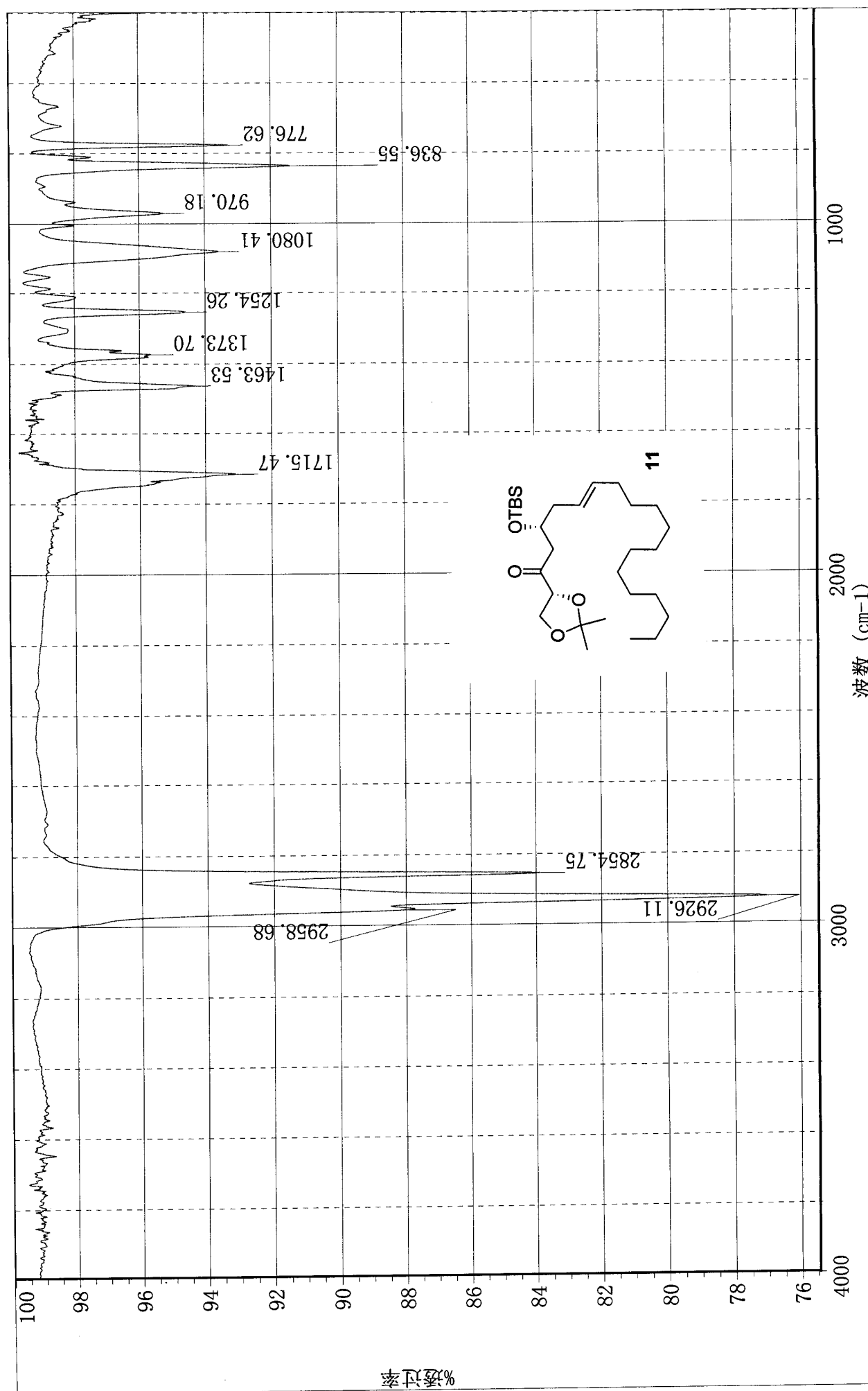

**yx-3-49

采集时间: 星期五 4月 01 18:52:59 2011 (GMT+08:00)



上海有机所生命有机化学国家重点实验室

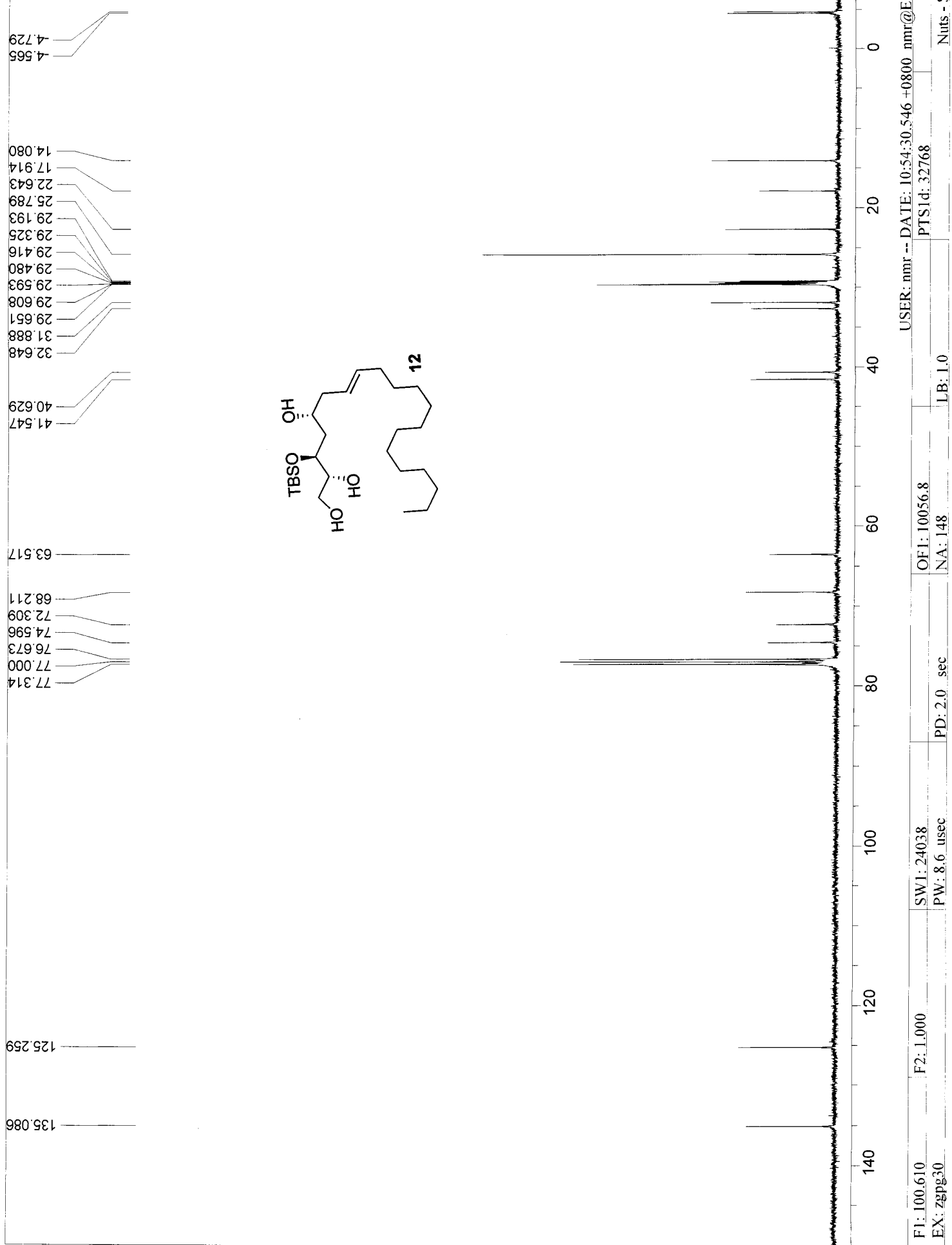

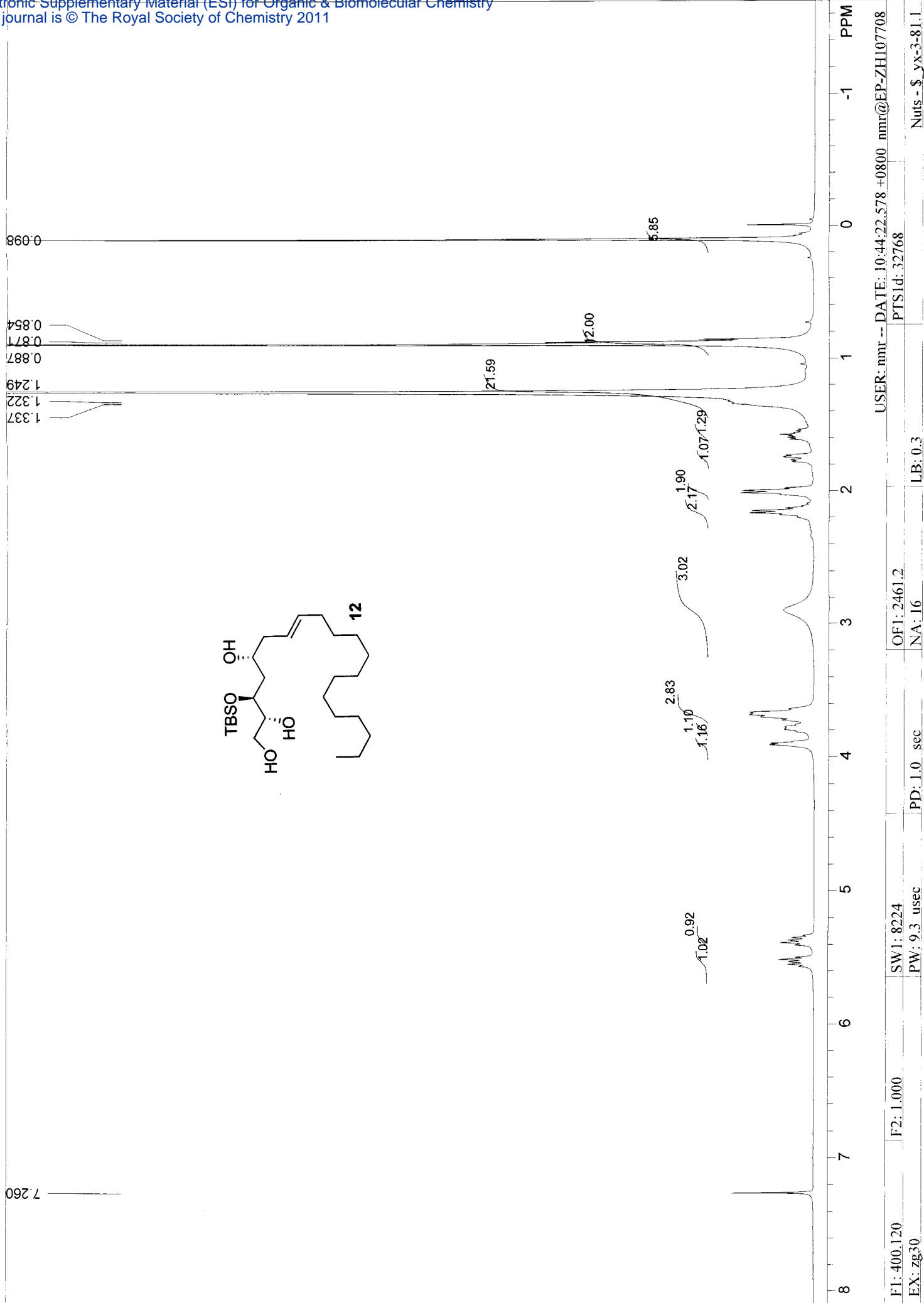

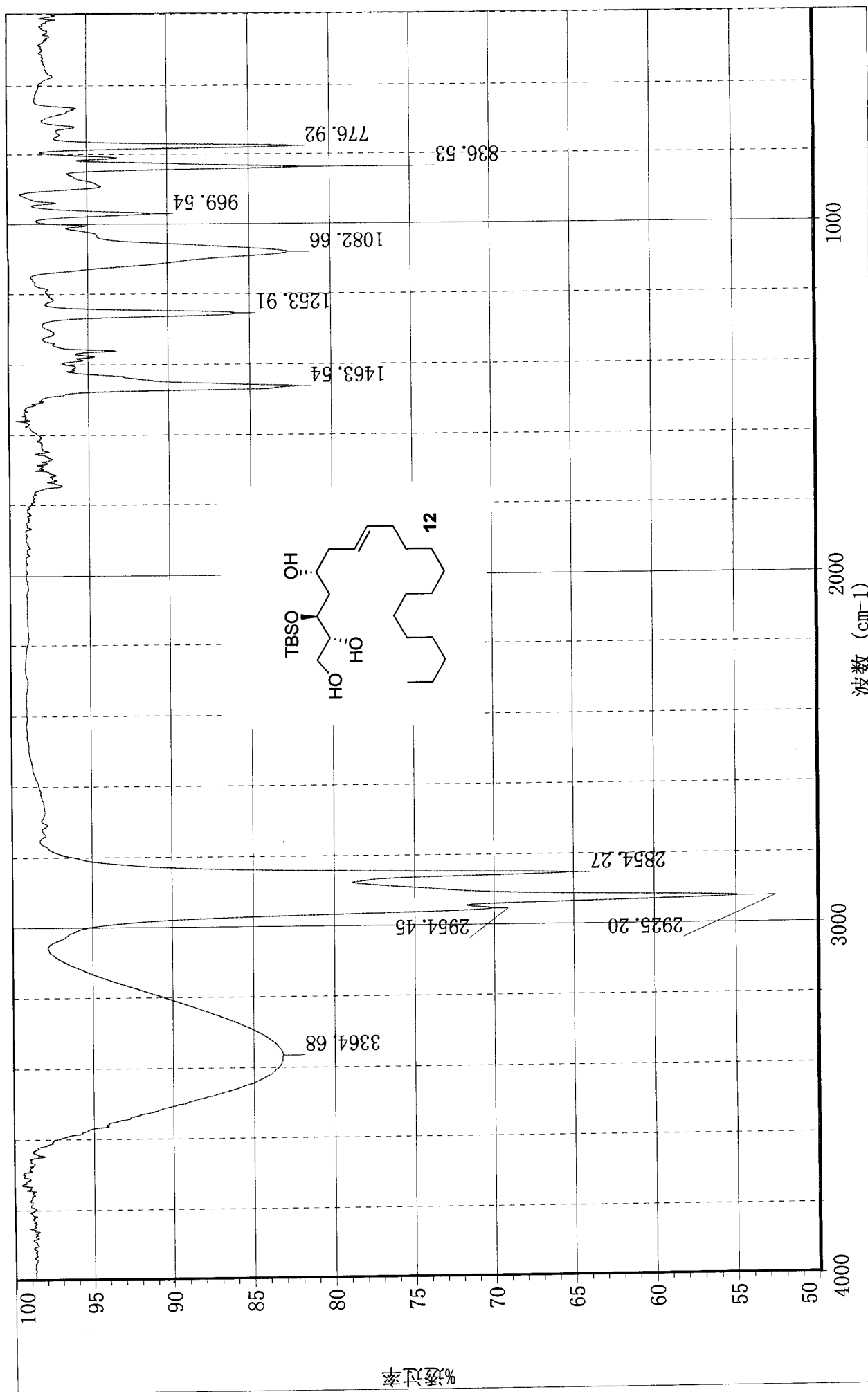

*yx-3-81

采集时间: 星期五 4月 01 19:04:51 2011 (GMT+08:00)



上海有机所生命有机化学国家重点实验室

5.431
5.385

14.083
18.249
22.665
25.847
29.190
29.334
29.444
29.476
29.621
29.658
31.895
32.647
38.379
40.990

67.196
68.221
69.405
76.673
77.000
77.314

125.609

134.651

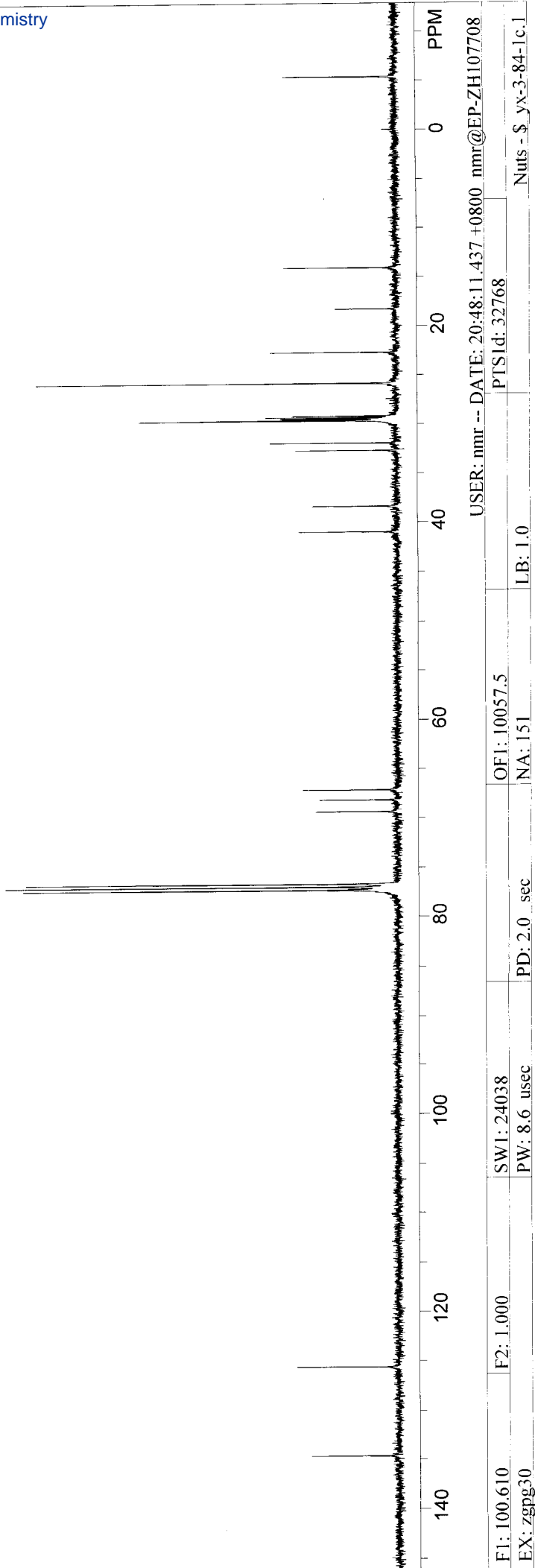
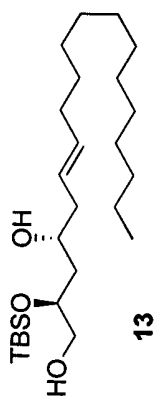

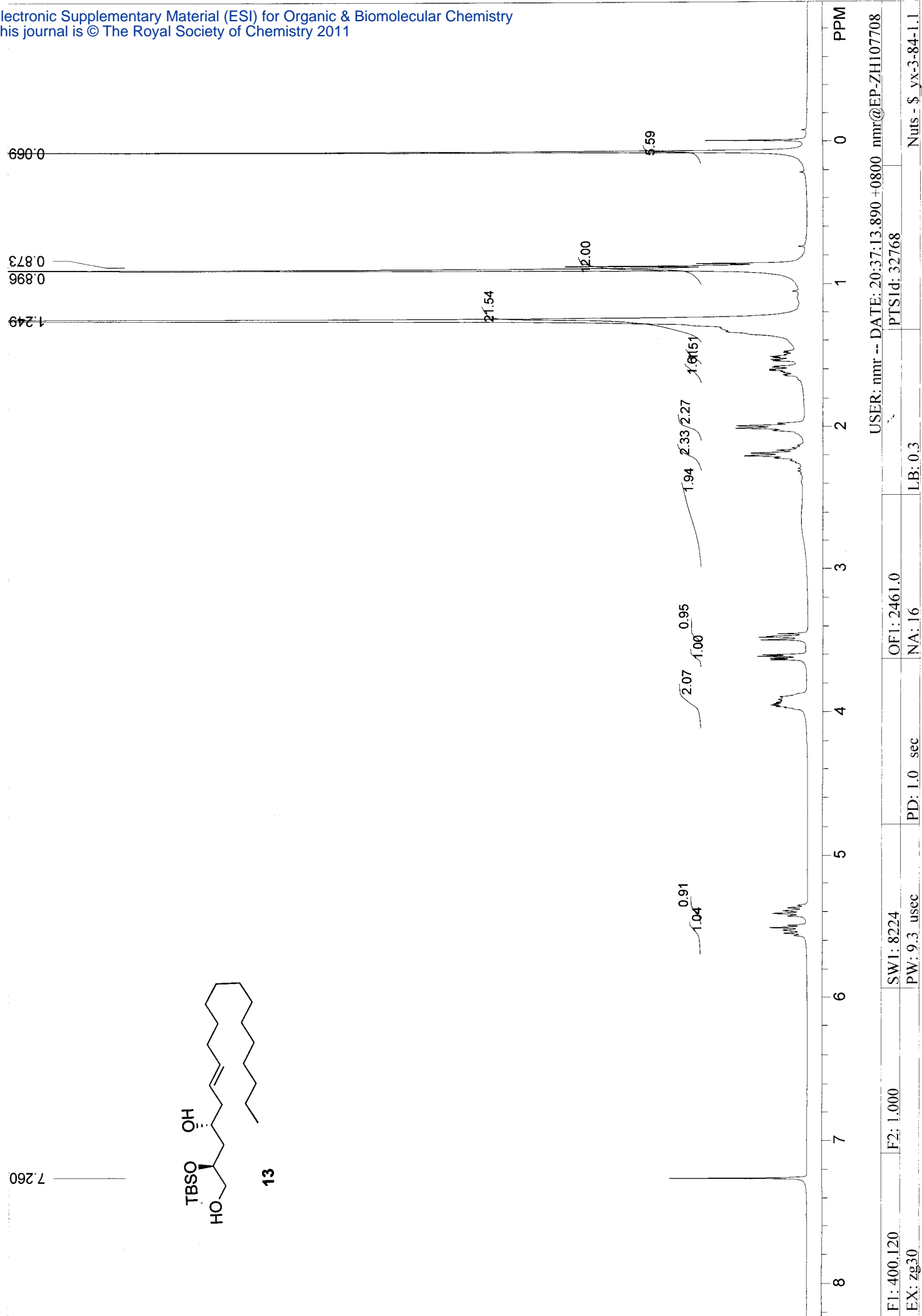

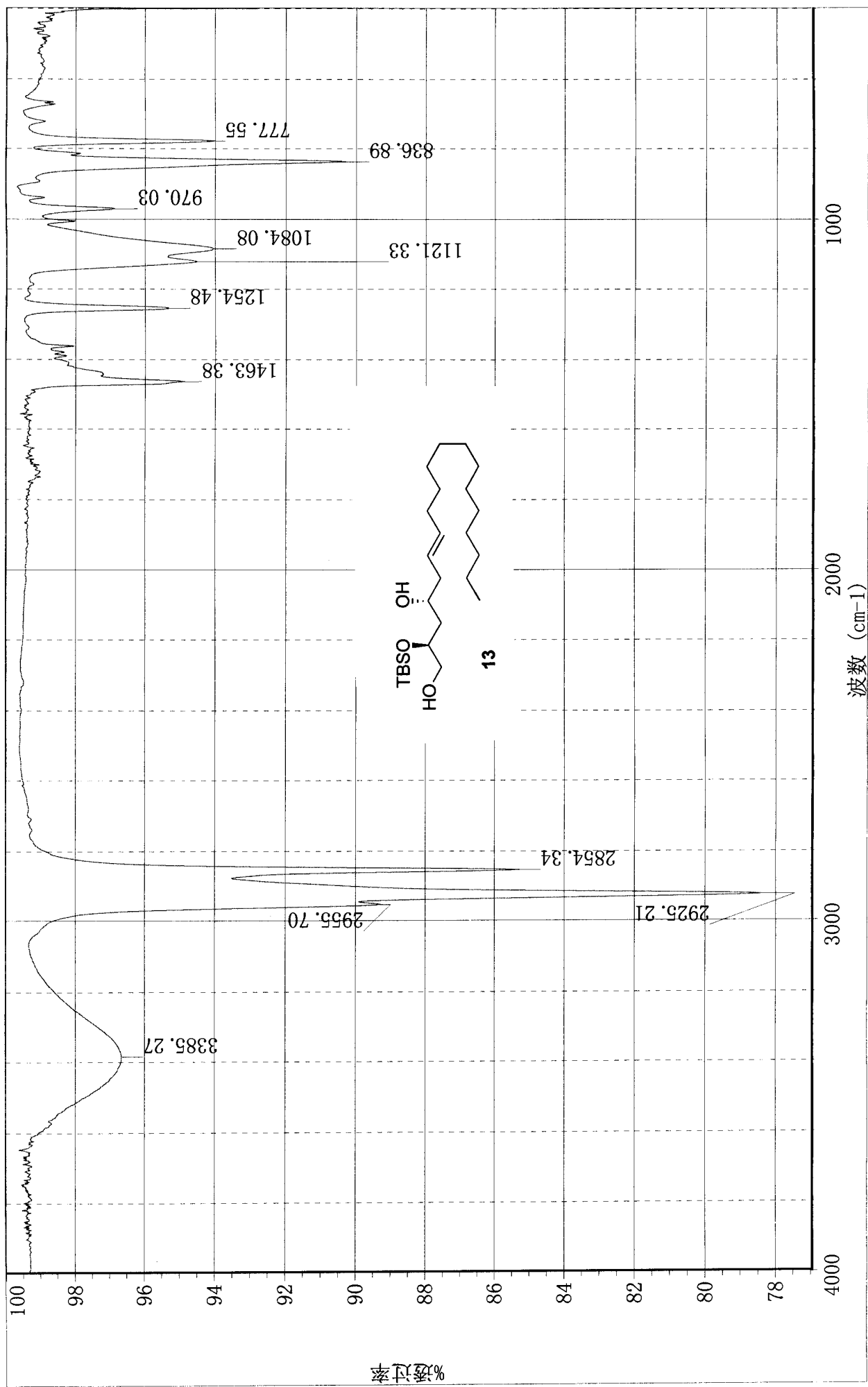

82 S

**yx-3-84-1

采集时间: 星期四 4月 07 21:27:29 2011 (GMT+08:00)

上海有机所生命有机化学国家重点实验室

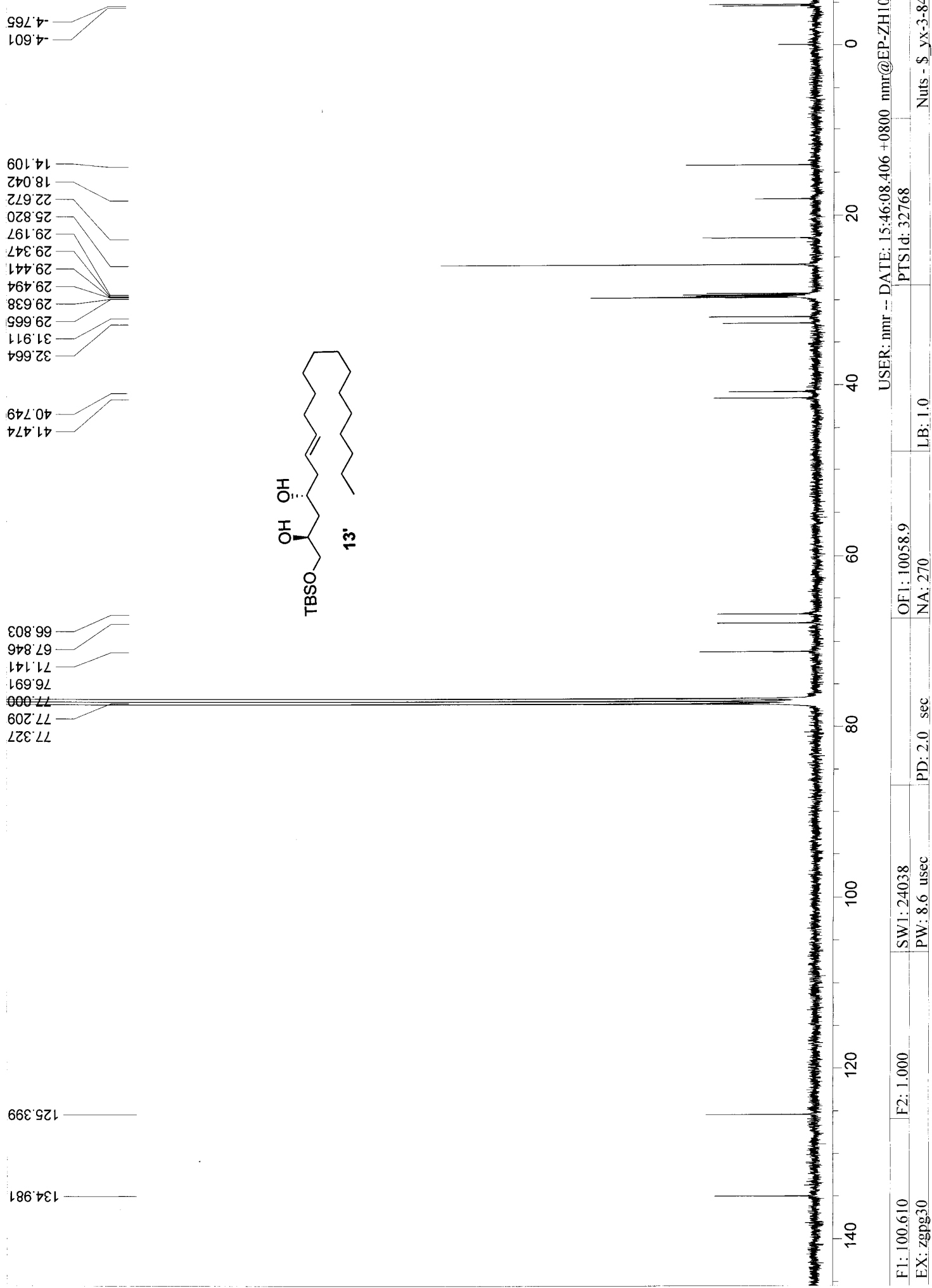

F1: 100.610 F2: 1.000 SW1: 24038 PD: 2.0 sec OF1: 10058.9
 EX: zgpg30 PW: 8.6 usec NA: 270 L.B: 1.0
 USER: nmr -- DATE: 15:46:08.406 +0800 nmr@EP-ZH107708
 PTSId: 32768 Nuts - \$ _yx-3-84-2c.1

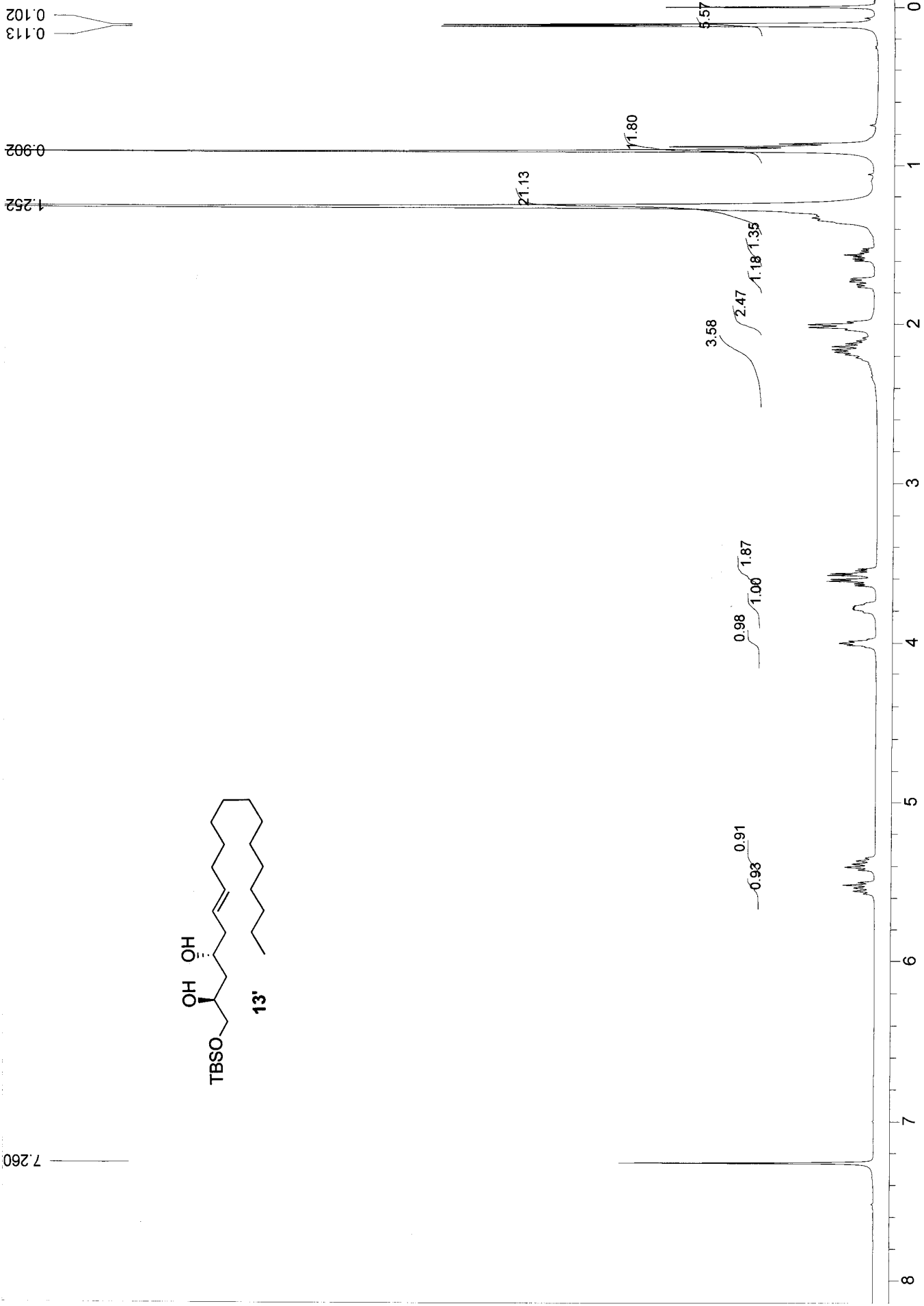
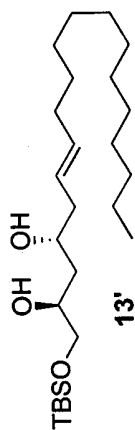

EX: zg30
F1: 400.120
F2: 1.000
SW1: 8224
PW: 9.3 usec
PD: 1.0 sec
OF1: 2461.1
NA: 16
LB: 0.3
PTSD: 32768
USER: nmr -- DATE: 20:30:38.859 +0800 nmr@EP-ZH107708
Nuts - \$ _yx-3-84-2.1

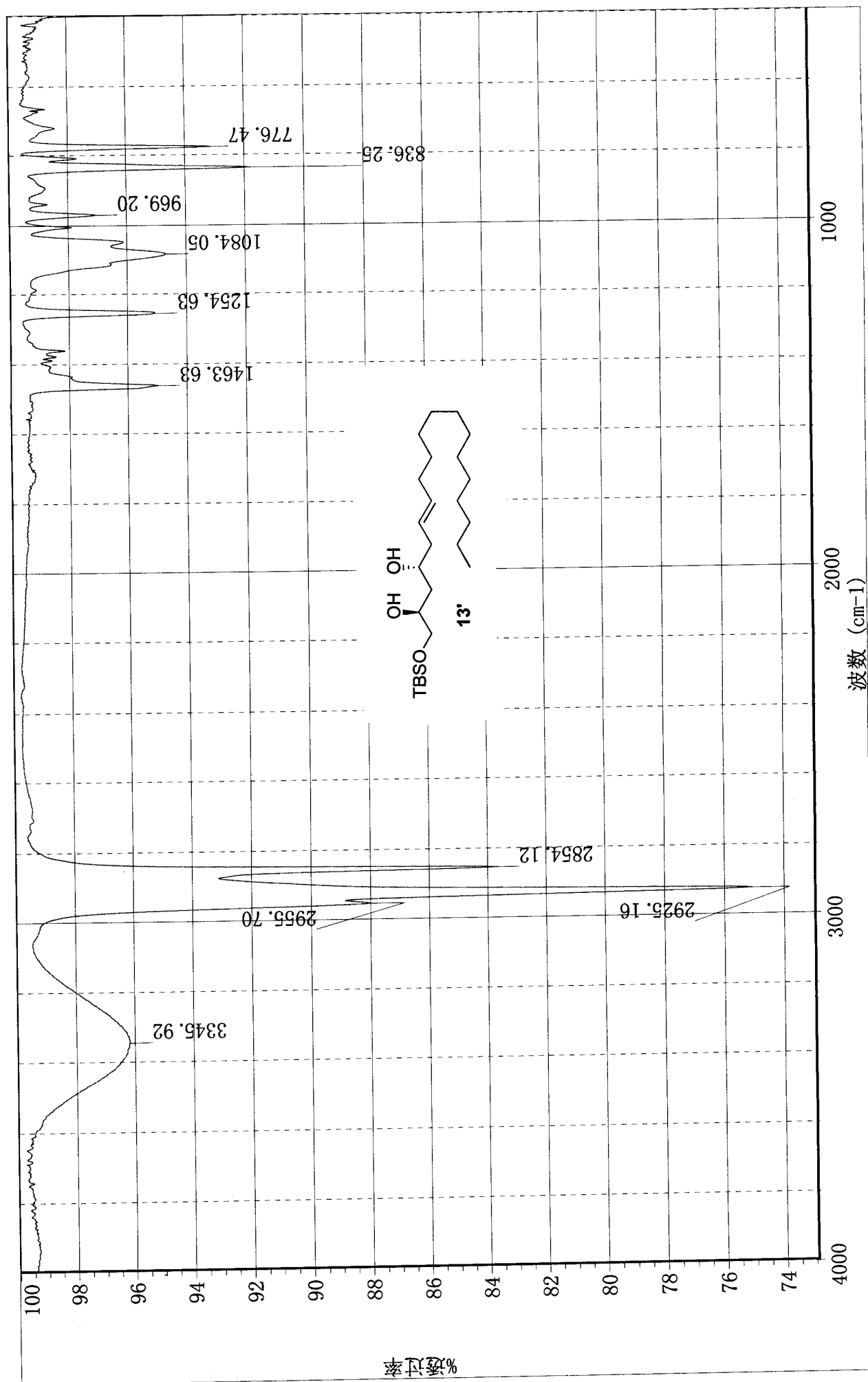

13 S

**yx-3-84-2

采集时间: 星期四 4月 07 21:35:09 2011 (GMT+08:00)

上海有机所生命有机化学国家重点实验室

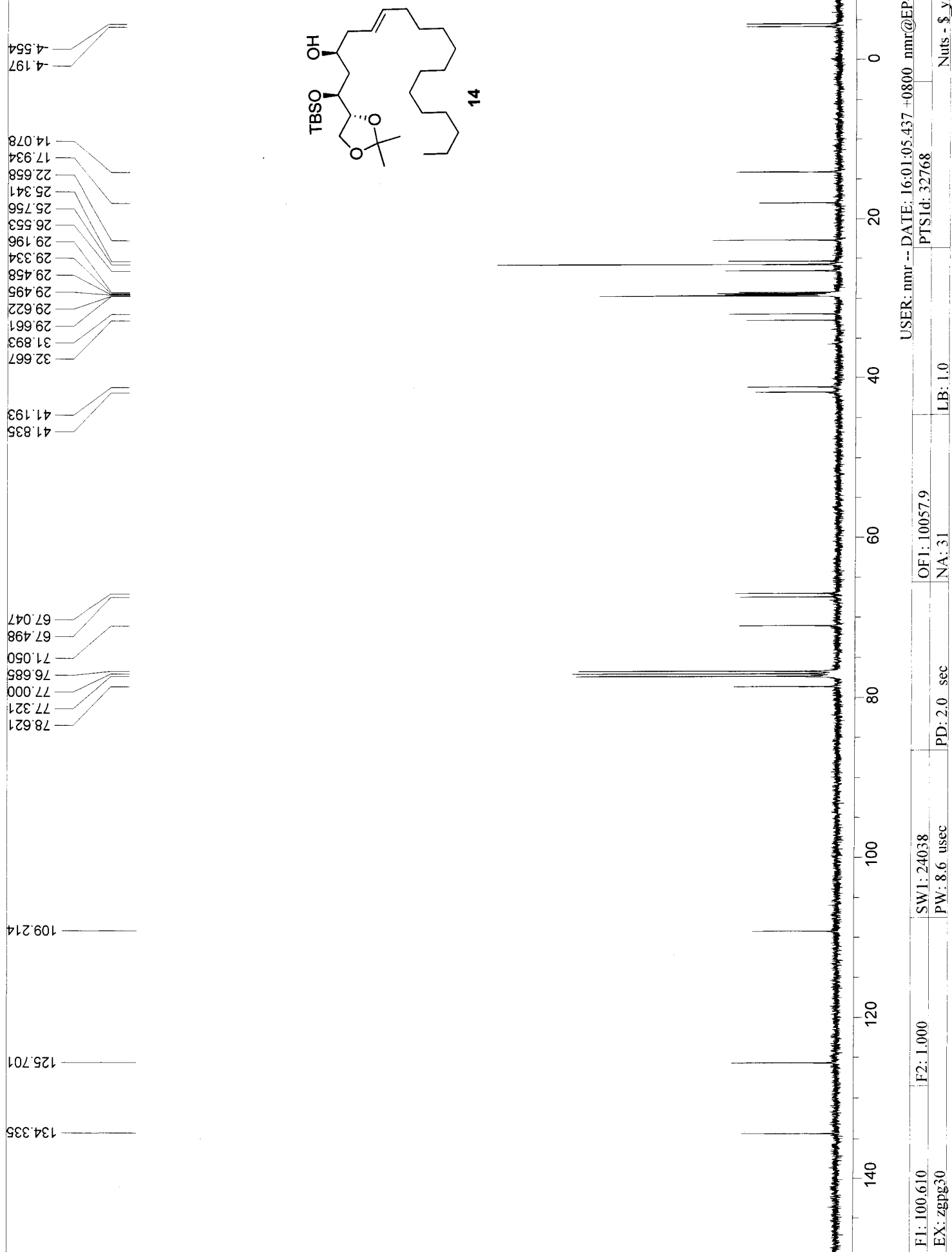

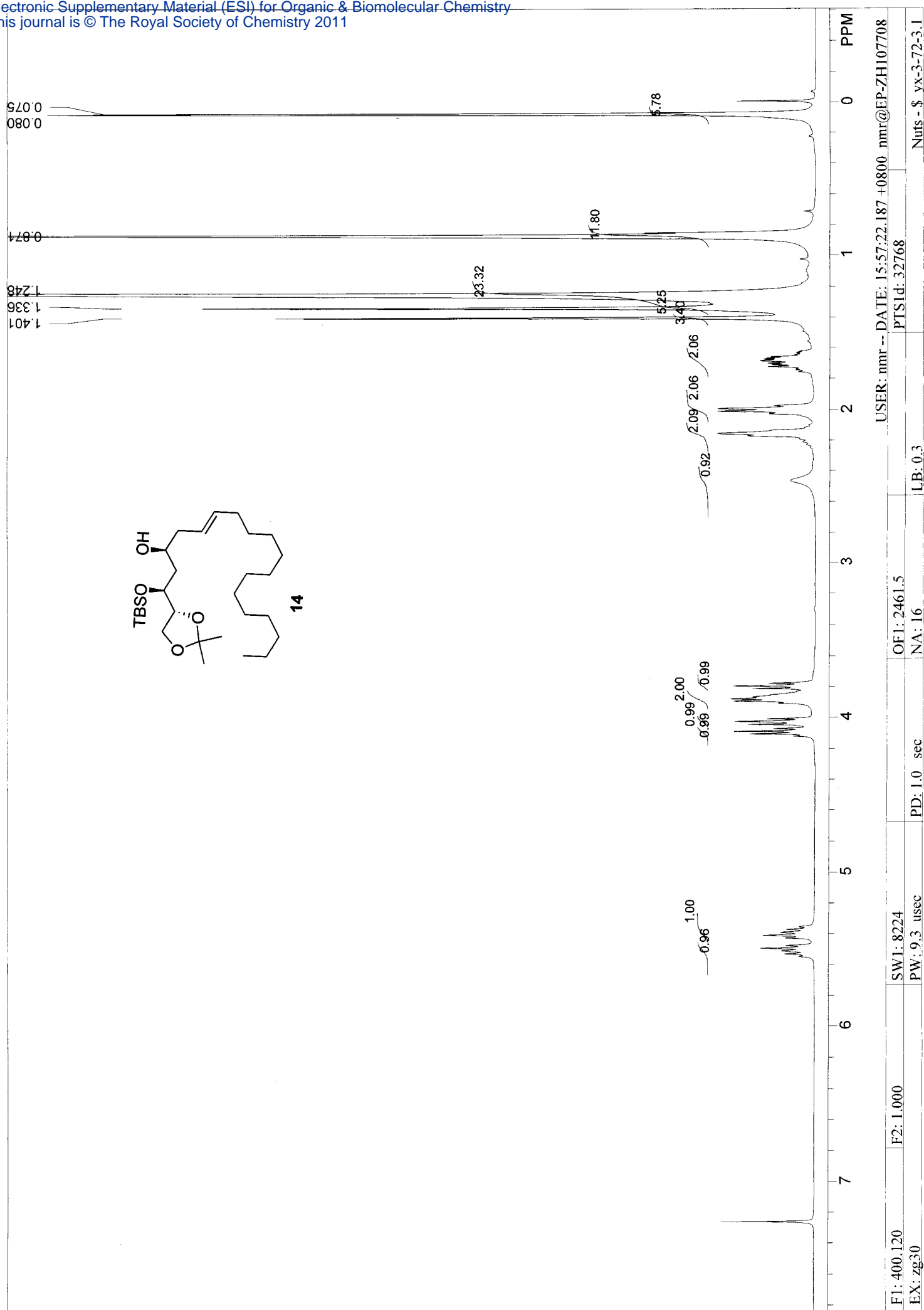
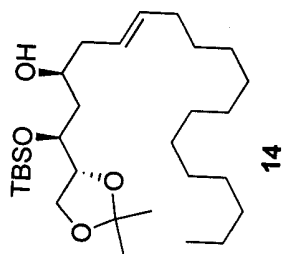

USER: mmr -- DATE: 15:57:22.187 +0800 .nmr@EP-ZHI07708
 PTSId: 32768

OF1: 2461.5
 NA: 16
 LB: 0.3

PD: 1.0 sec

SW1: 8224
 PW: 9.3 usec

F1: 400.120
 F2: 1.000

EX: zg30

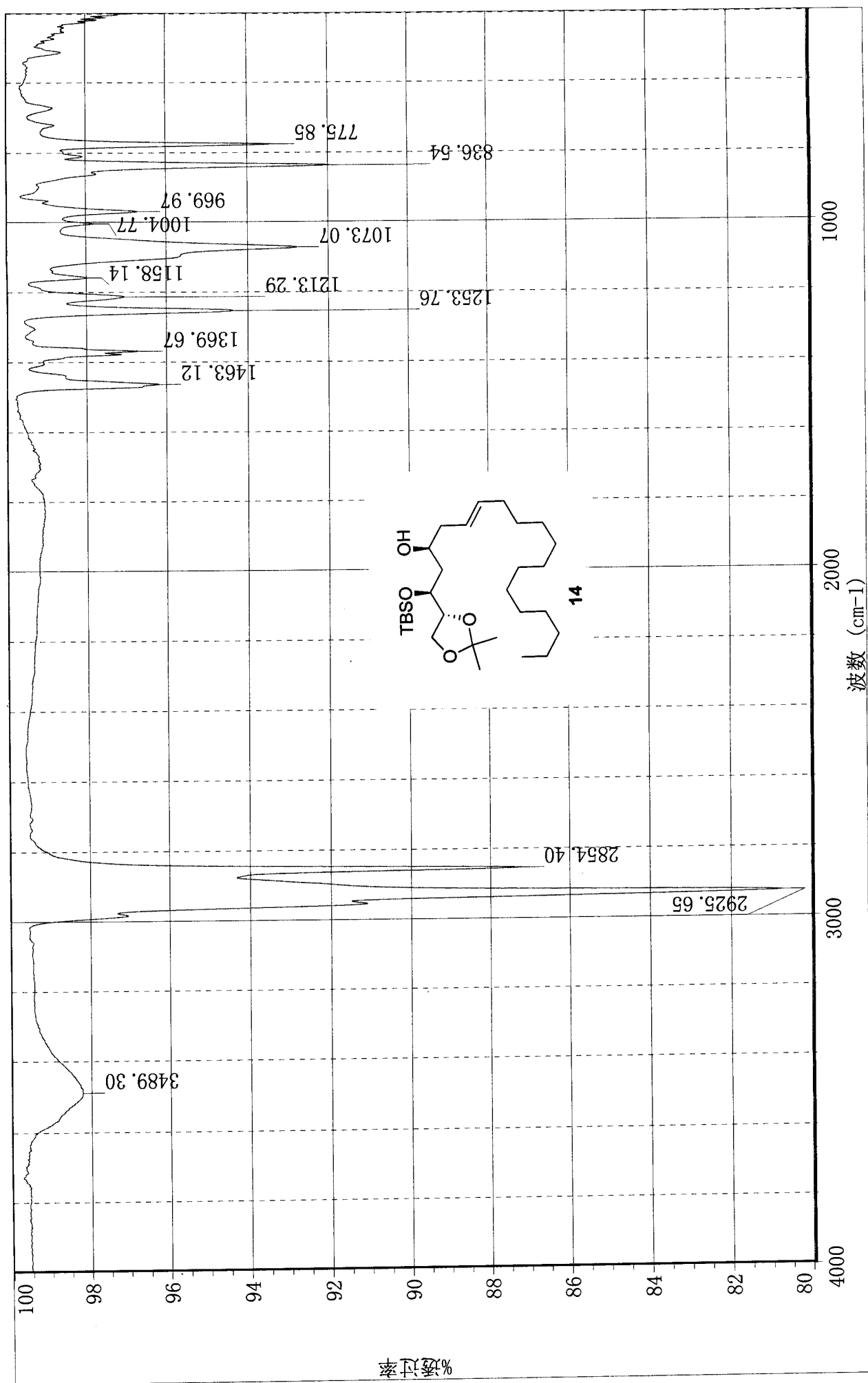

*星期一 3月 28 20:18:29 2011 X-3-12-3
采集时间: 星期一 3月 28 20:19:10 2011 (GMT+08:00)

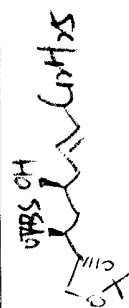

上海有机所生命有机化学国家重点实验室

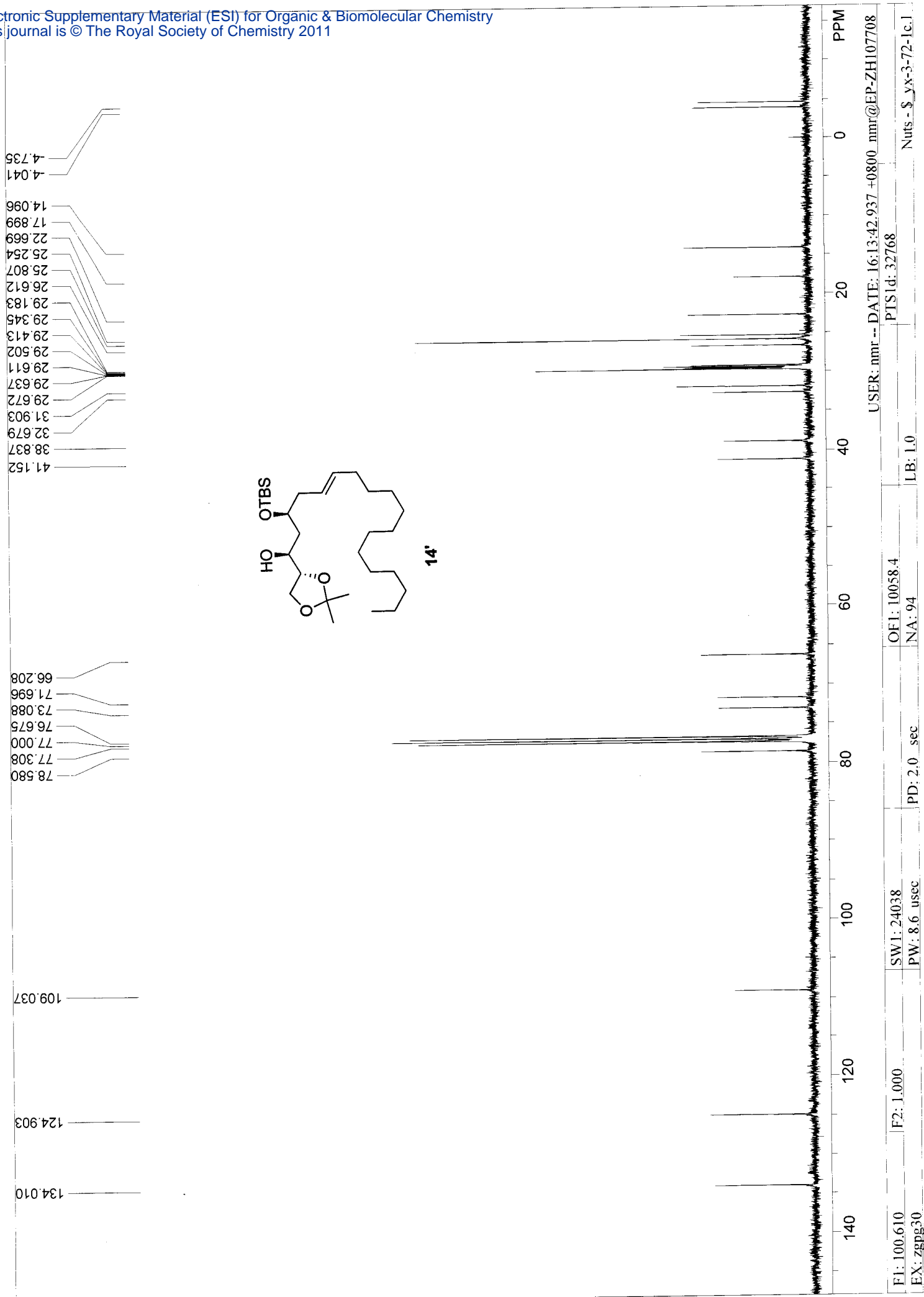

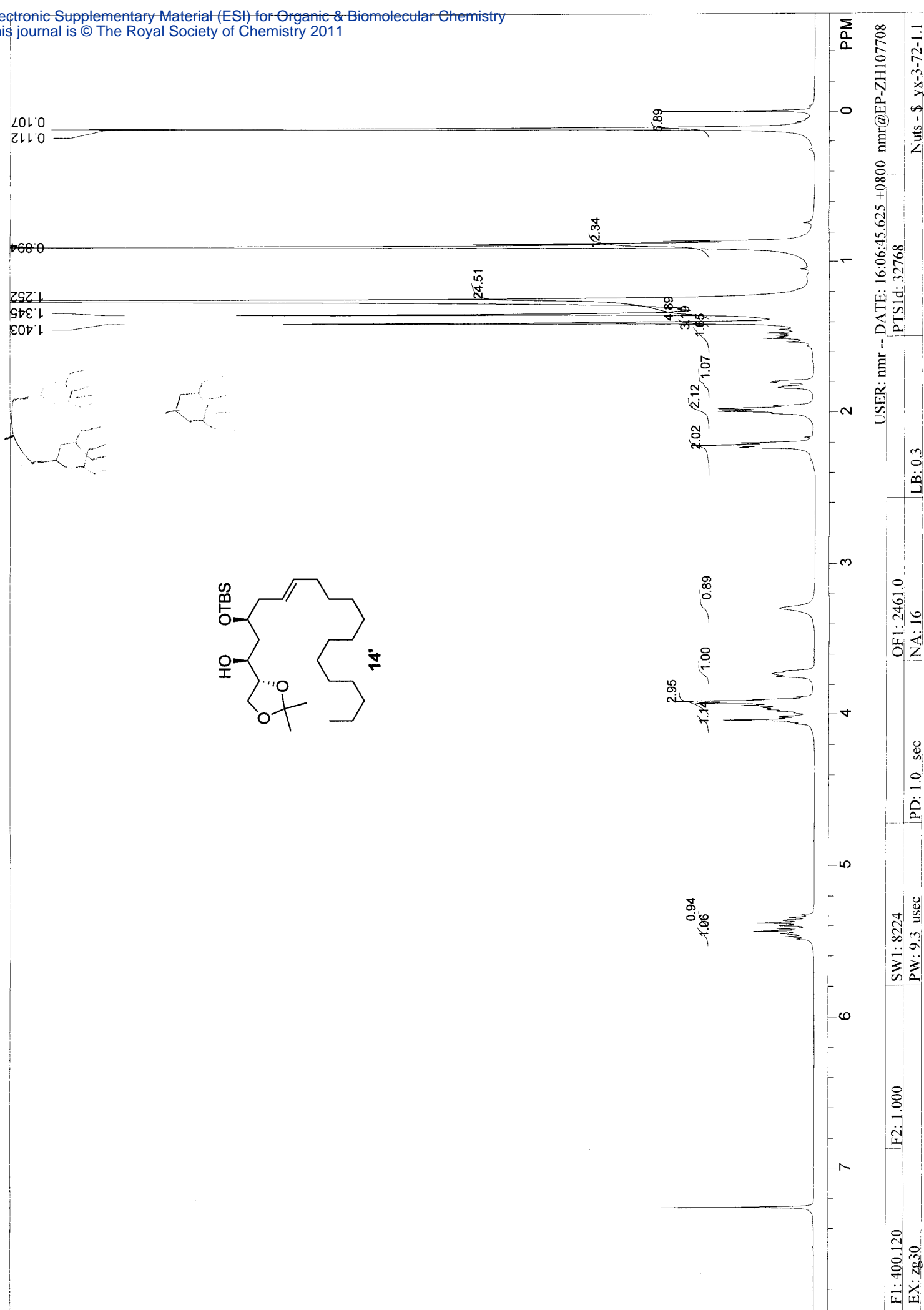

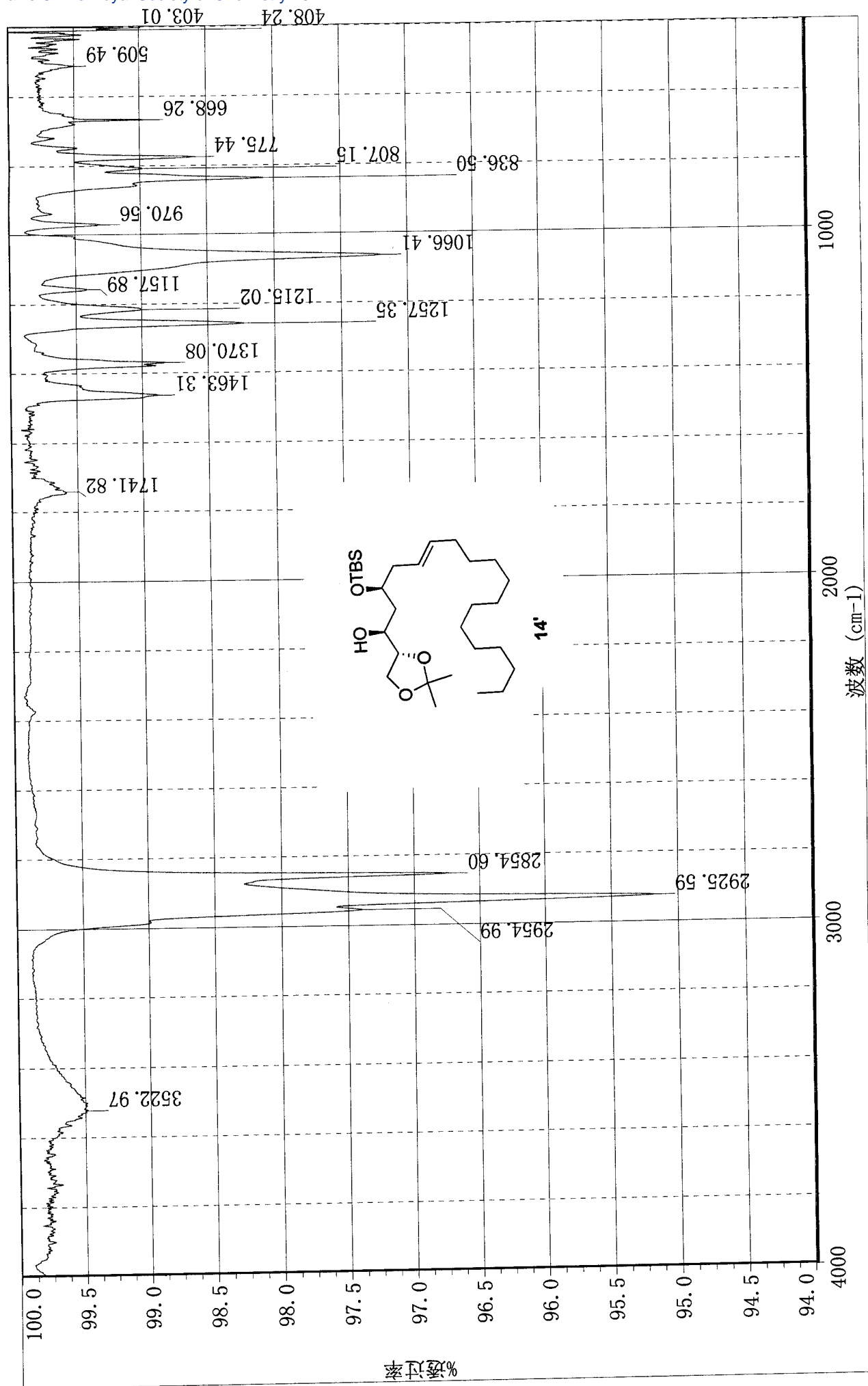

**yx-3-72-1-a

采集时间: 星期二 3月 29 10:06:24 2011 (GMT+08:00)

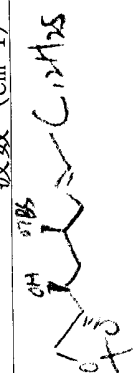

上海有机所生命有机化学国家重点实验室

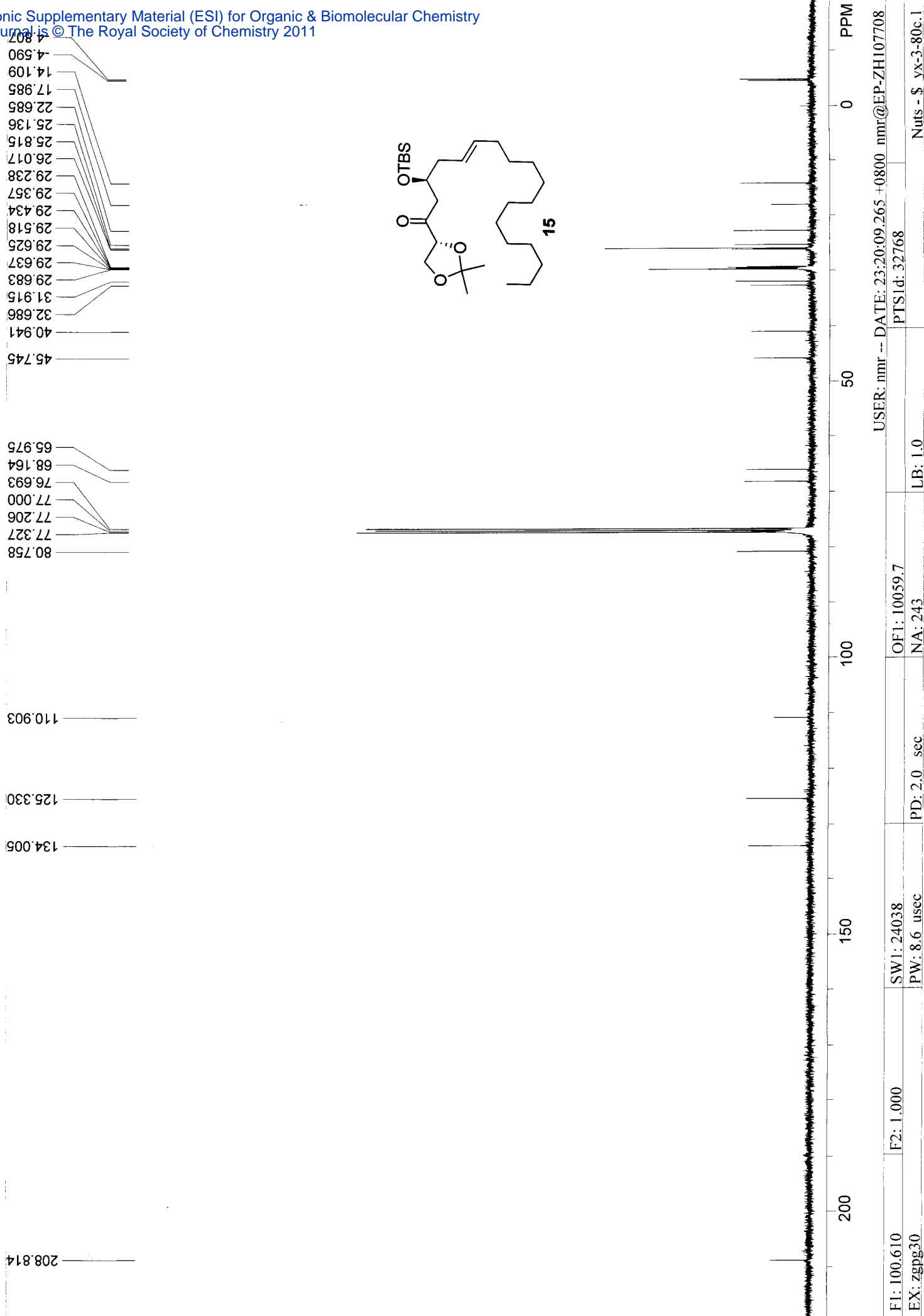

0.063
0.014
0.952
1.253
1.386
1.455

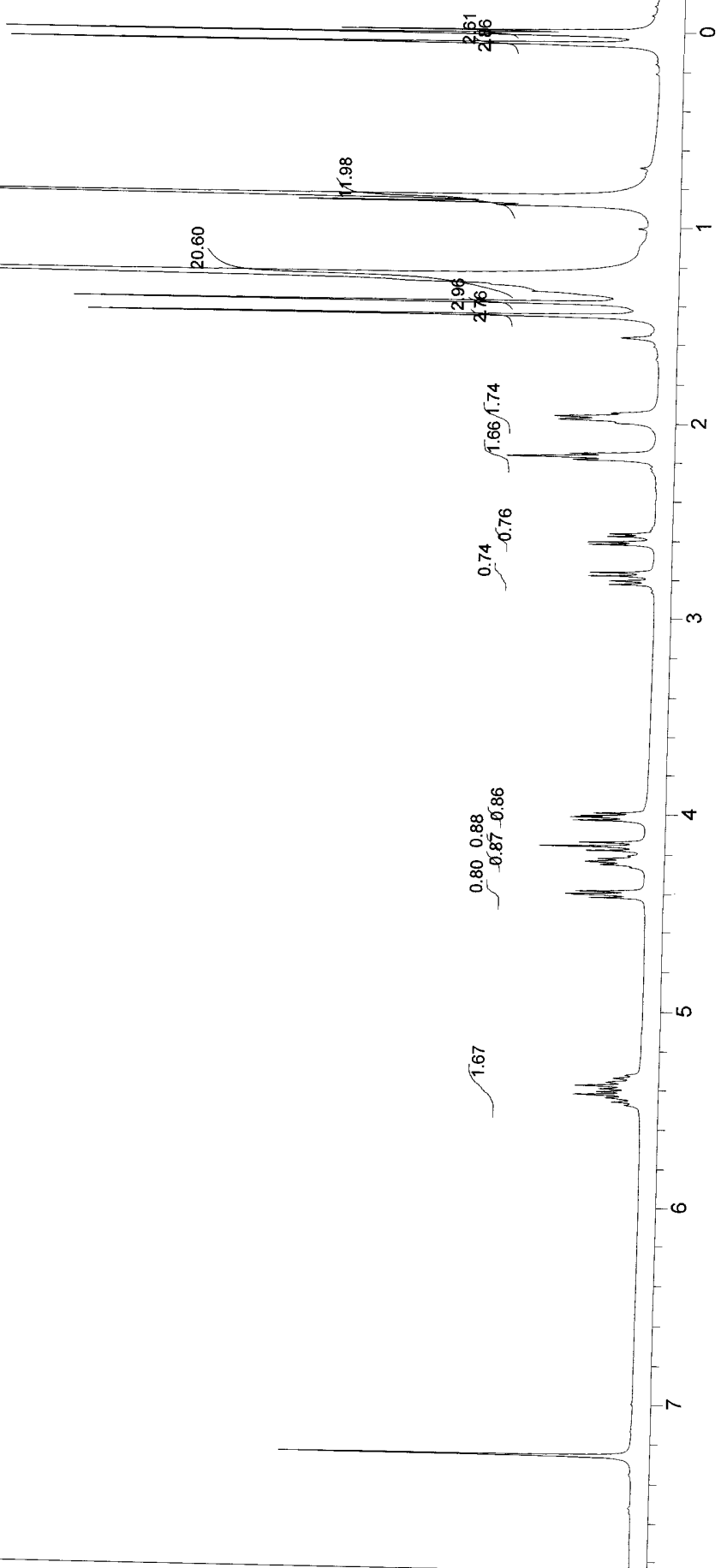
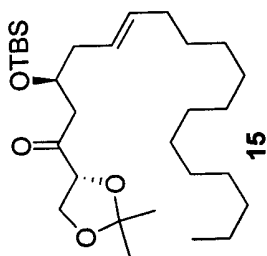

F1: 400.120 F2: 1.000 SW1: 8224
EX: zg30 PD: 1.0 sec PD: 1.0 sec
OF1: 2461.0 NA: 16
USER: nmr -- DATE: 20:54:30.875 +0800 nmr@EP-ZH1107708
PTSI: 32768 LB: 0.3
Nuts - \$ _yx-3-80c.1

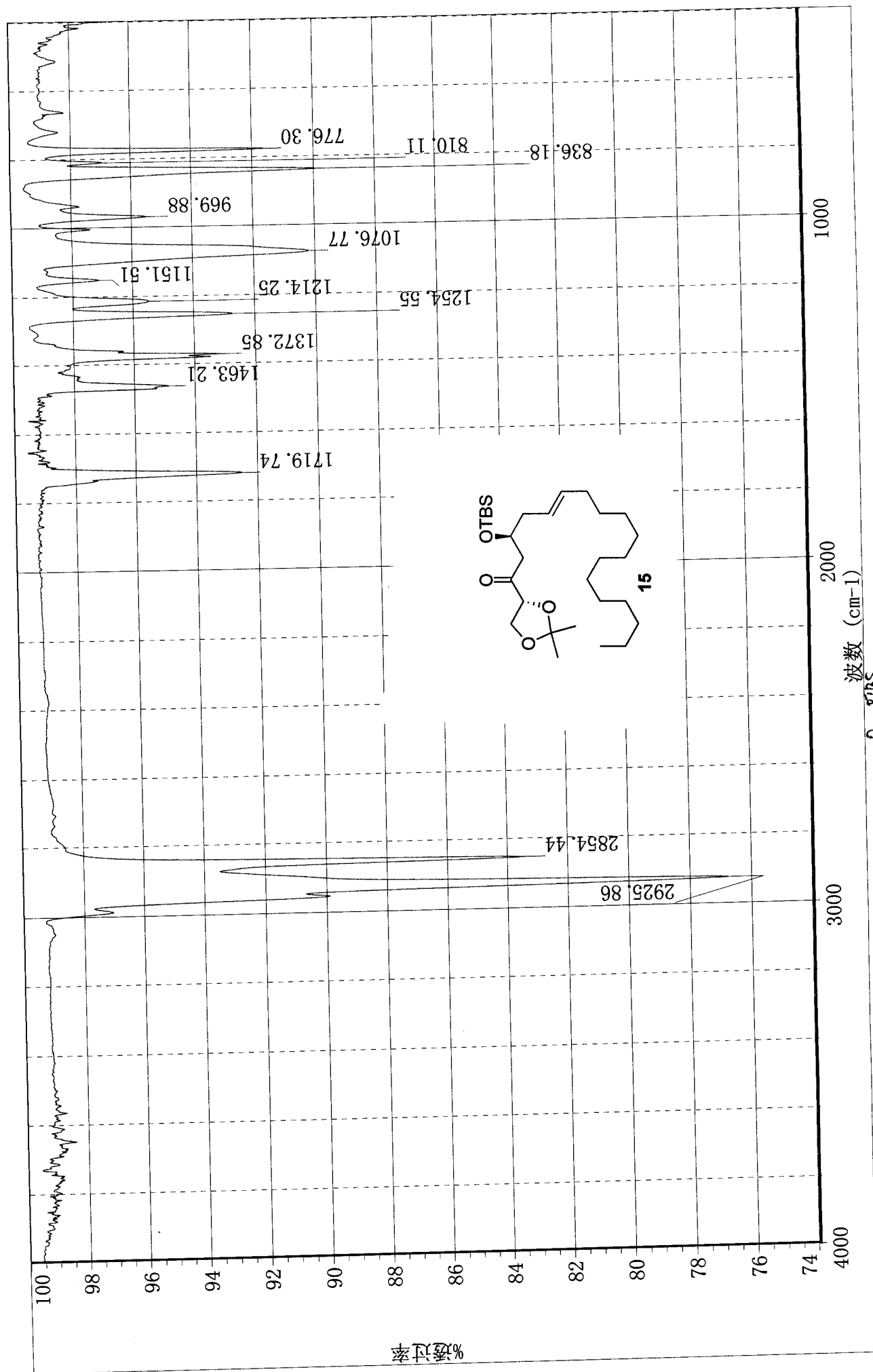

**yx-3-80

采集时间: 星期五 4月 01 18:47:00 2011 (GMT+08:00)

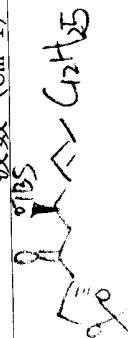

上海有机所生命有机化学国家重点实验室

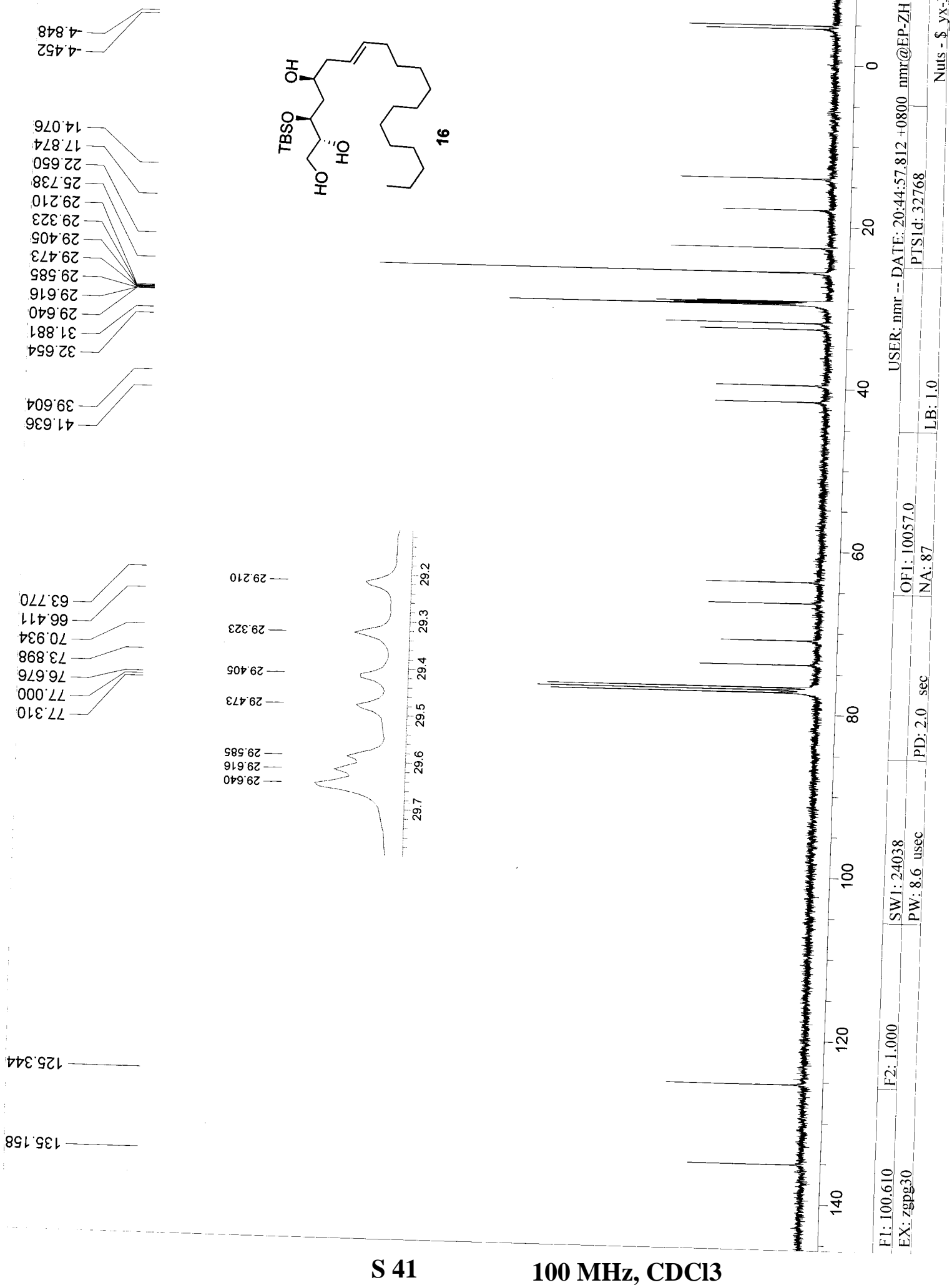

S 41

100 MHz, CDCl₃

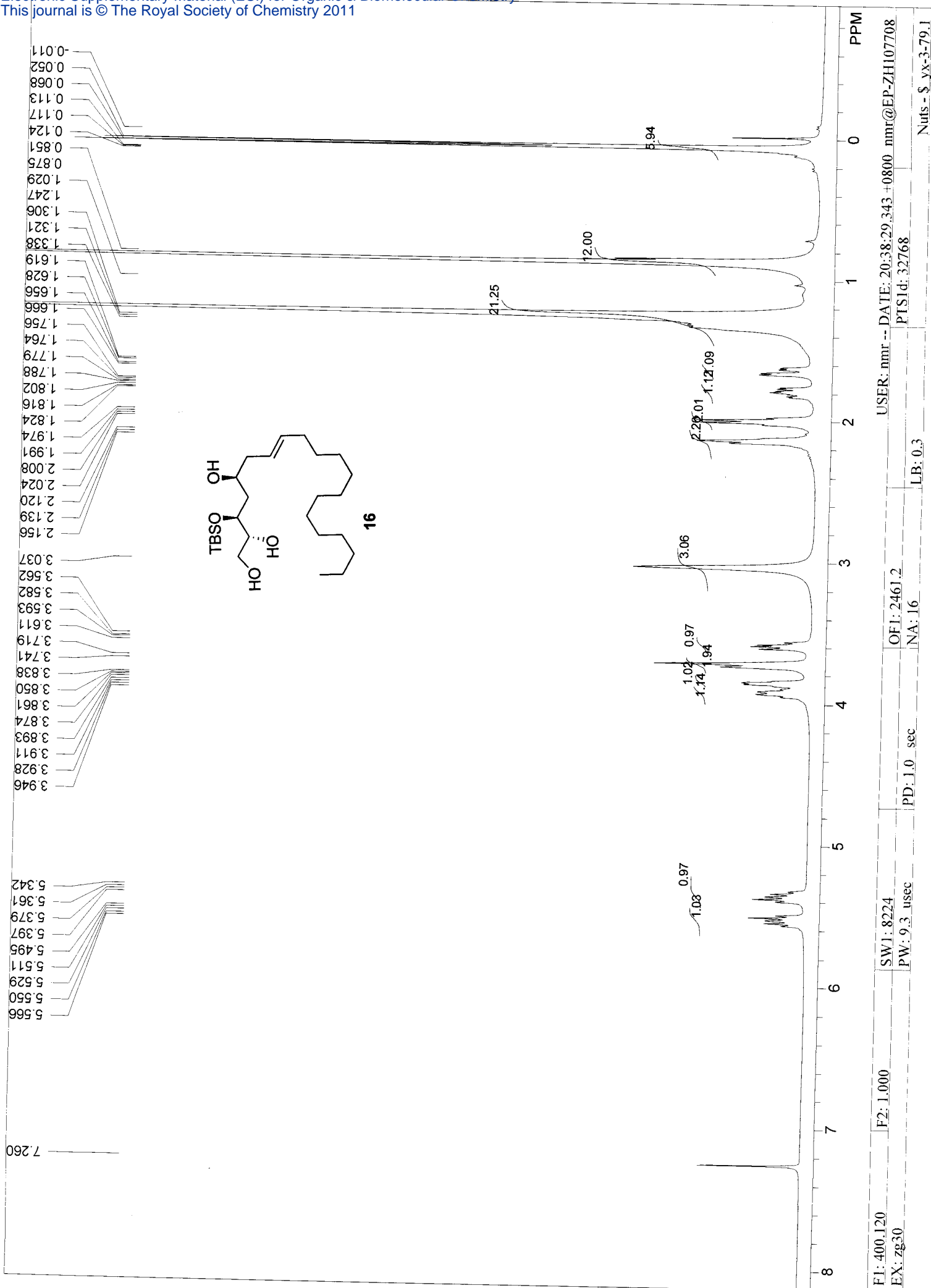

F1: 400.120
EX: zg30

F2: 1.000

SW1: 8224
PW: 9.3 usec

PD: 1.0 sec

NA: 16

OF1: 2461.2

PTSId: 32768

USER: nmr -- DATE: 20:38:29.343 +0800 nmr@EP-ZHI07708

LB: 0.3

Nuts - \$ _yx-3-79.1

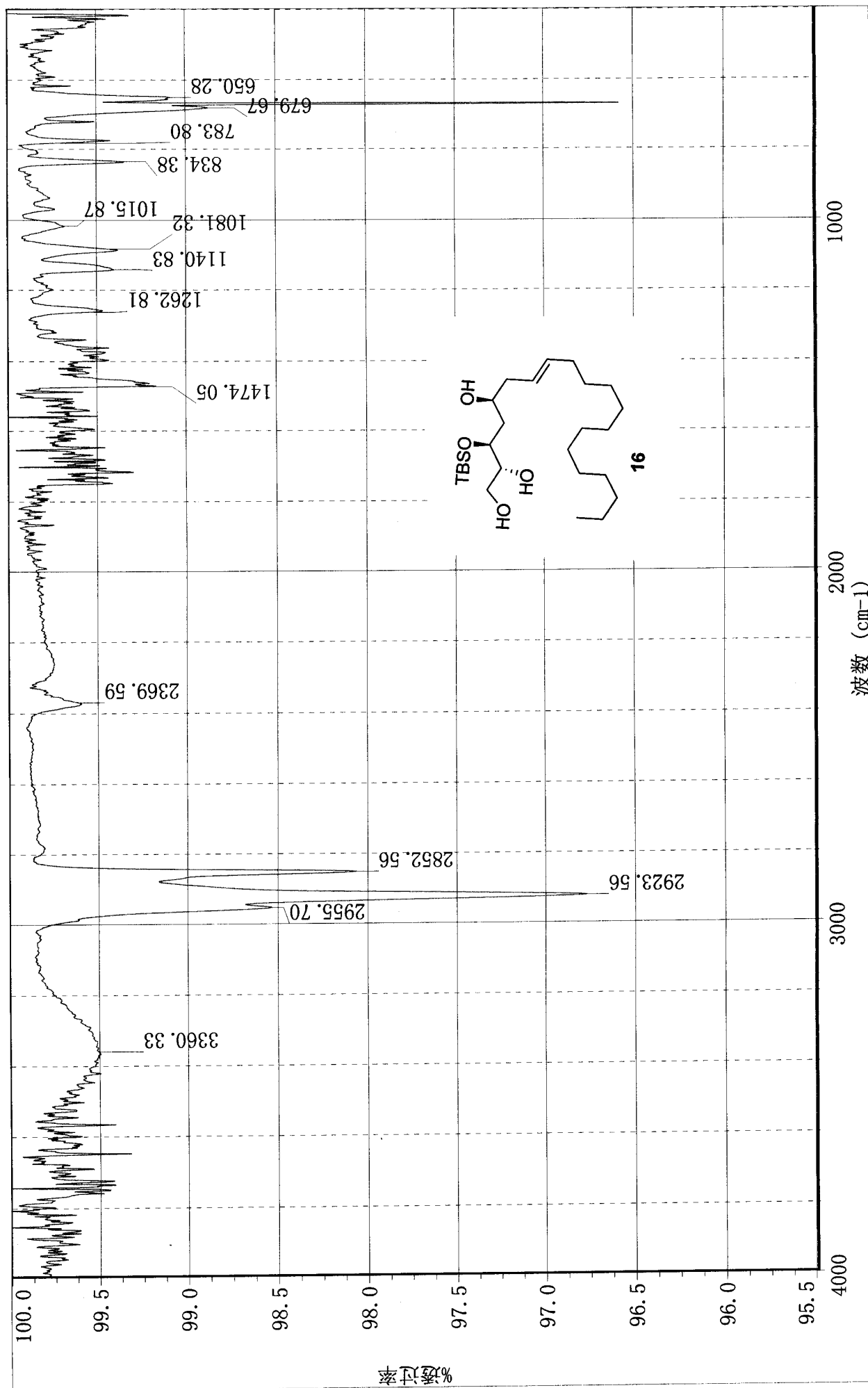

**yx-3-79

采集时间: 星期一 5月 09 10:44:51 2011 (GMT+08:00)

Handwritten signature and initials.

上海有机所生命有机化学国家重点实验室

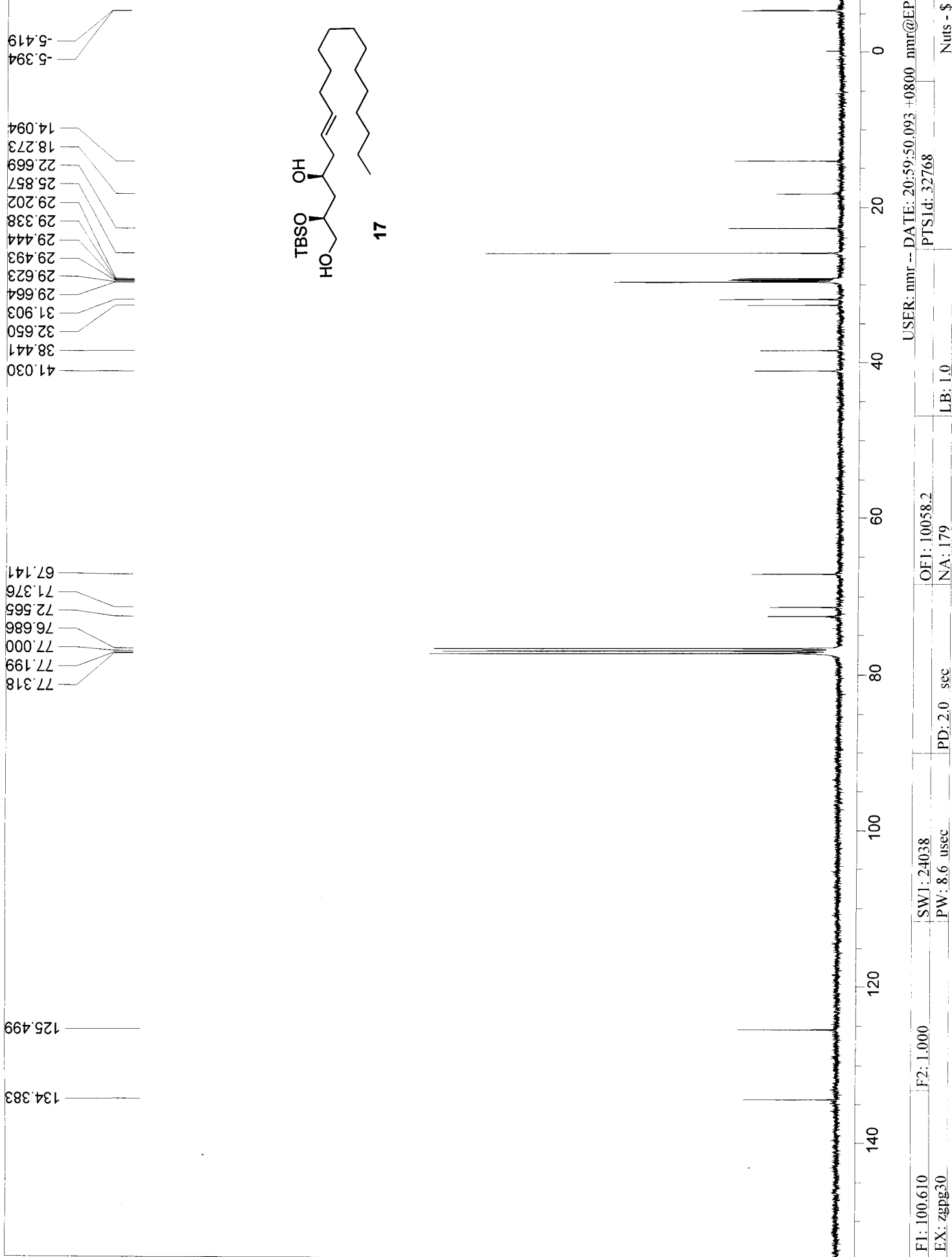

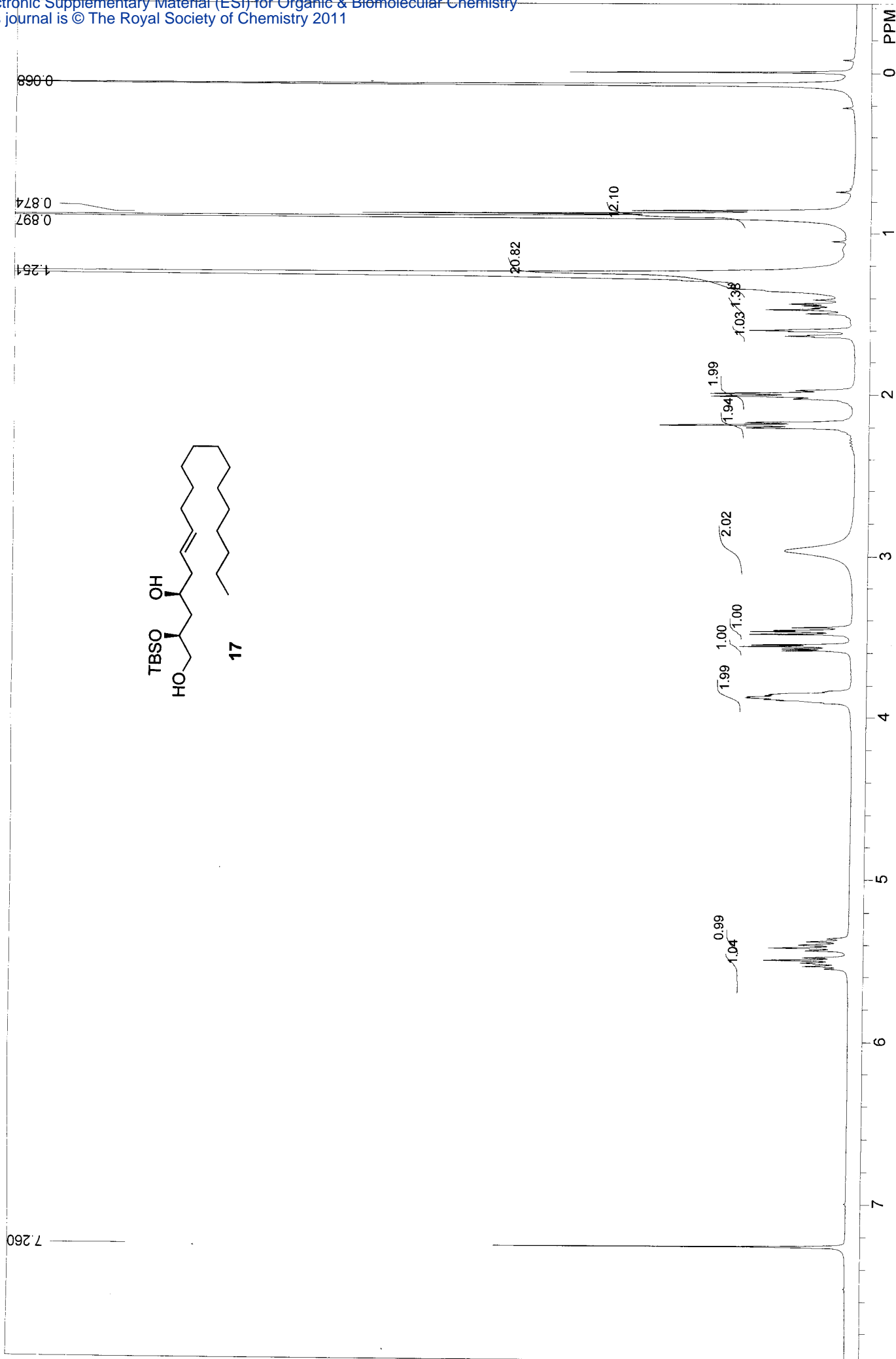

USER: nmr -- DATE: 21-02-2011 08:00 nmr@EP-ZHI07708

PTS1d: 32768

LB: 0.3

OF1: 2461.0

NA: 16

PD: 1.0 sec

SW1: 8224

PW: 9.3 usec

F2: 1.000

F1: 400.120

EX: zg30

Nuts - \$ yx-3-83.1

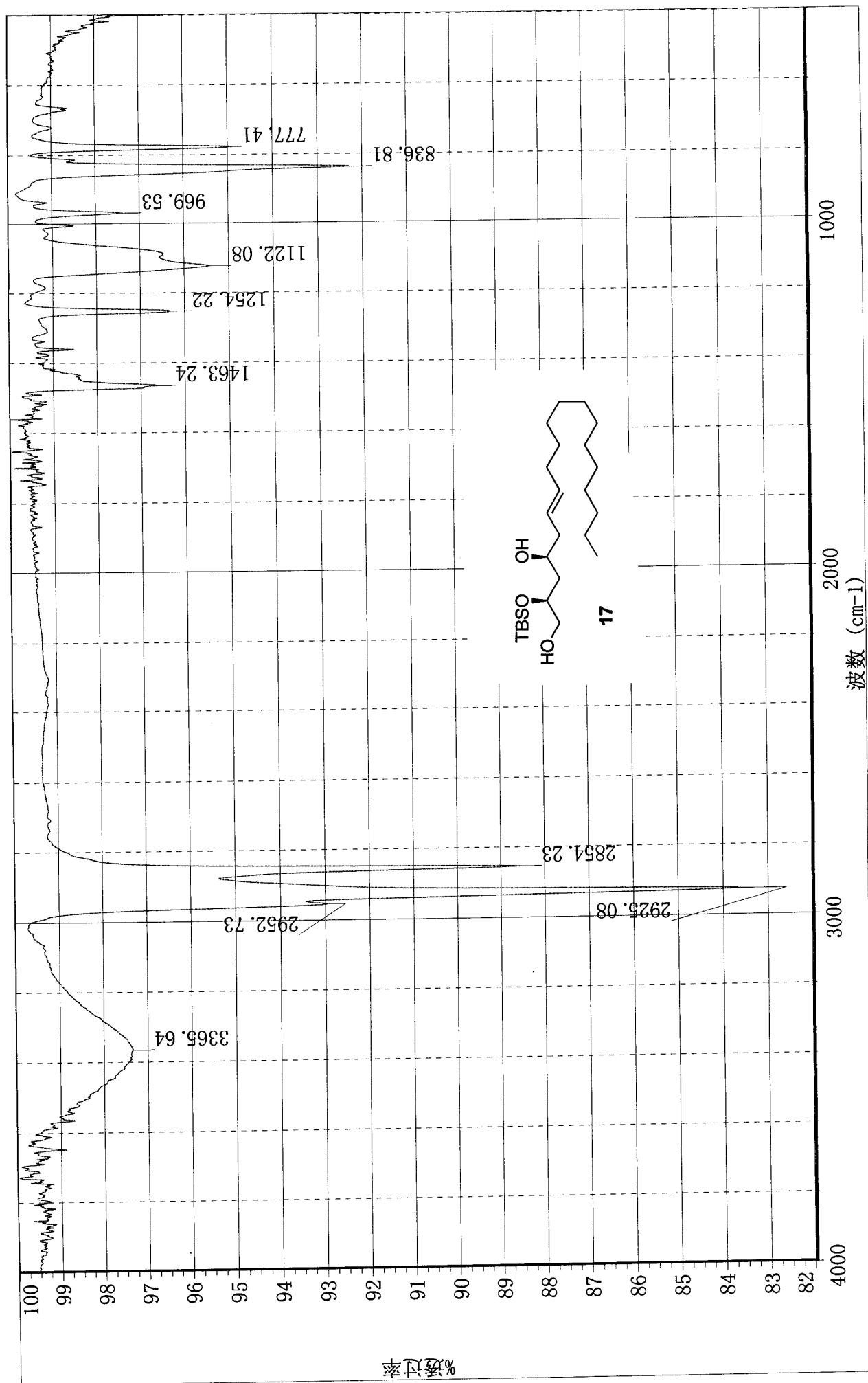

*yx-3-83

采集时间: 星期五 4月 01 18:59:16 2011 (GMT+08:00)



上海有机所生命有机化学国家重点实验室

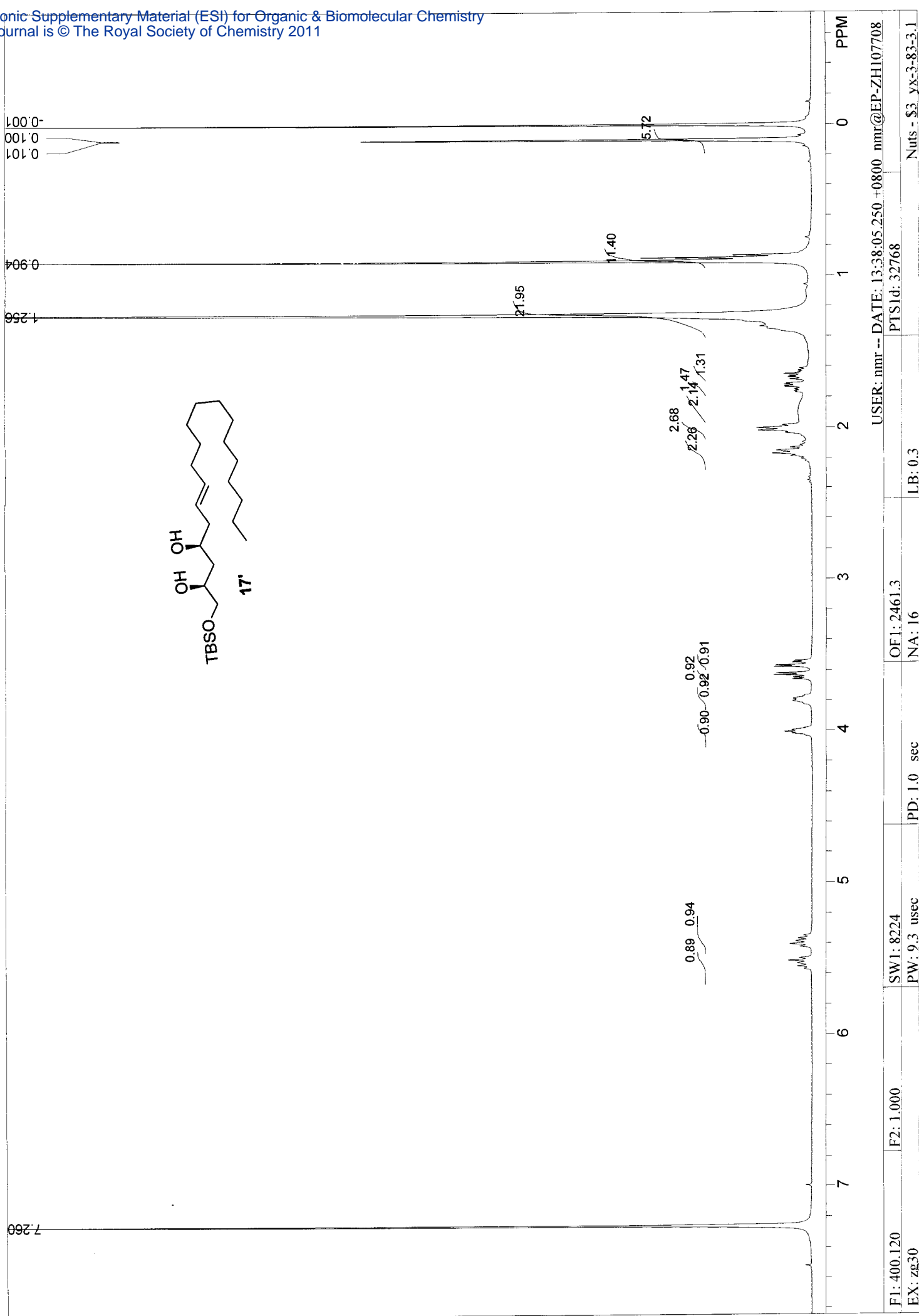

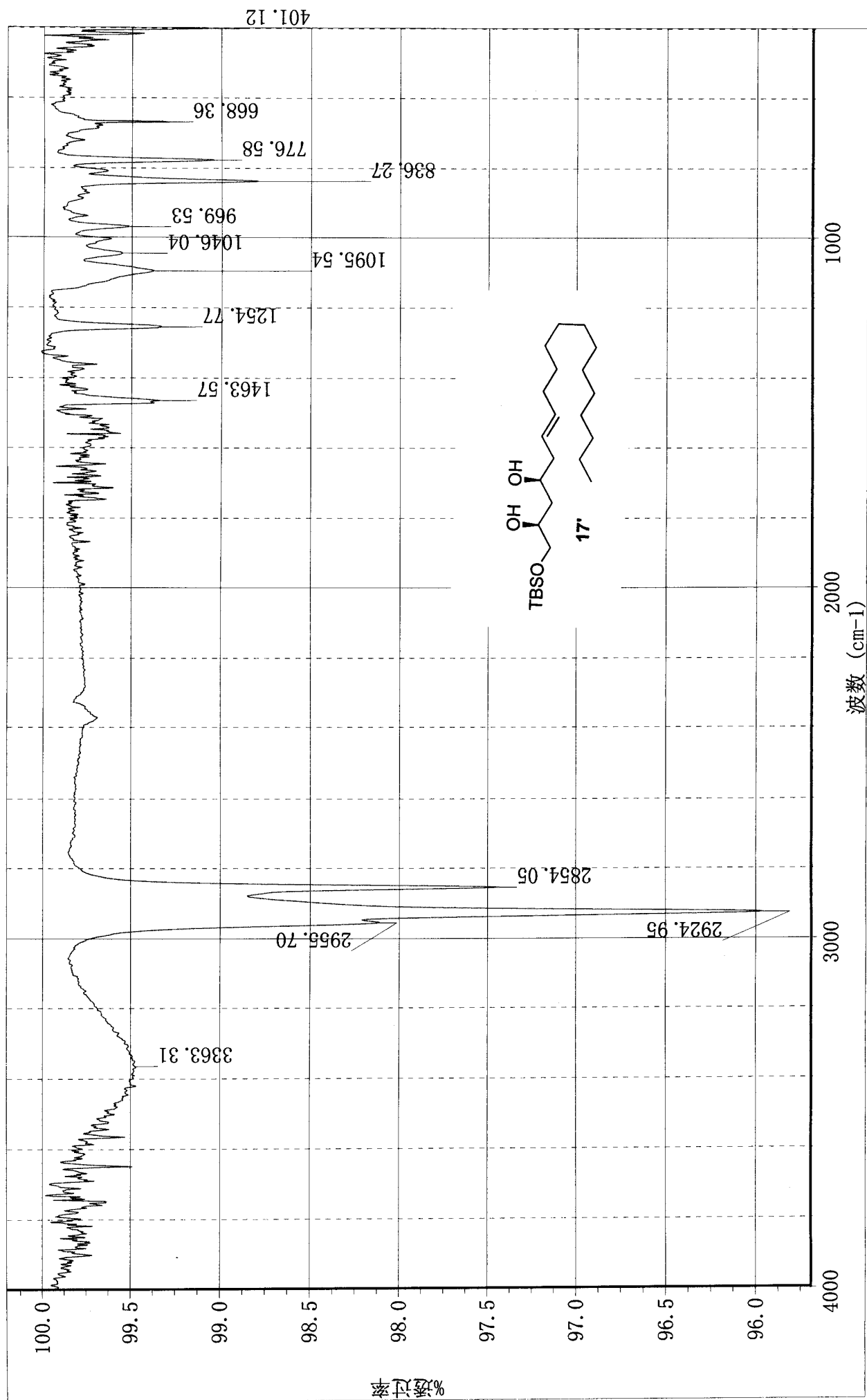

**yx-3-83-3

采集时间: 星期一 5月 09 10:32:43 2011 (GMT+08:00)

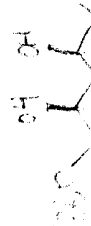

Gr 175 上海有机所生命有机化学国家重点实验室

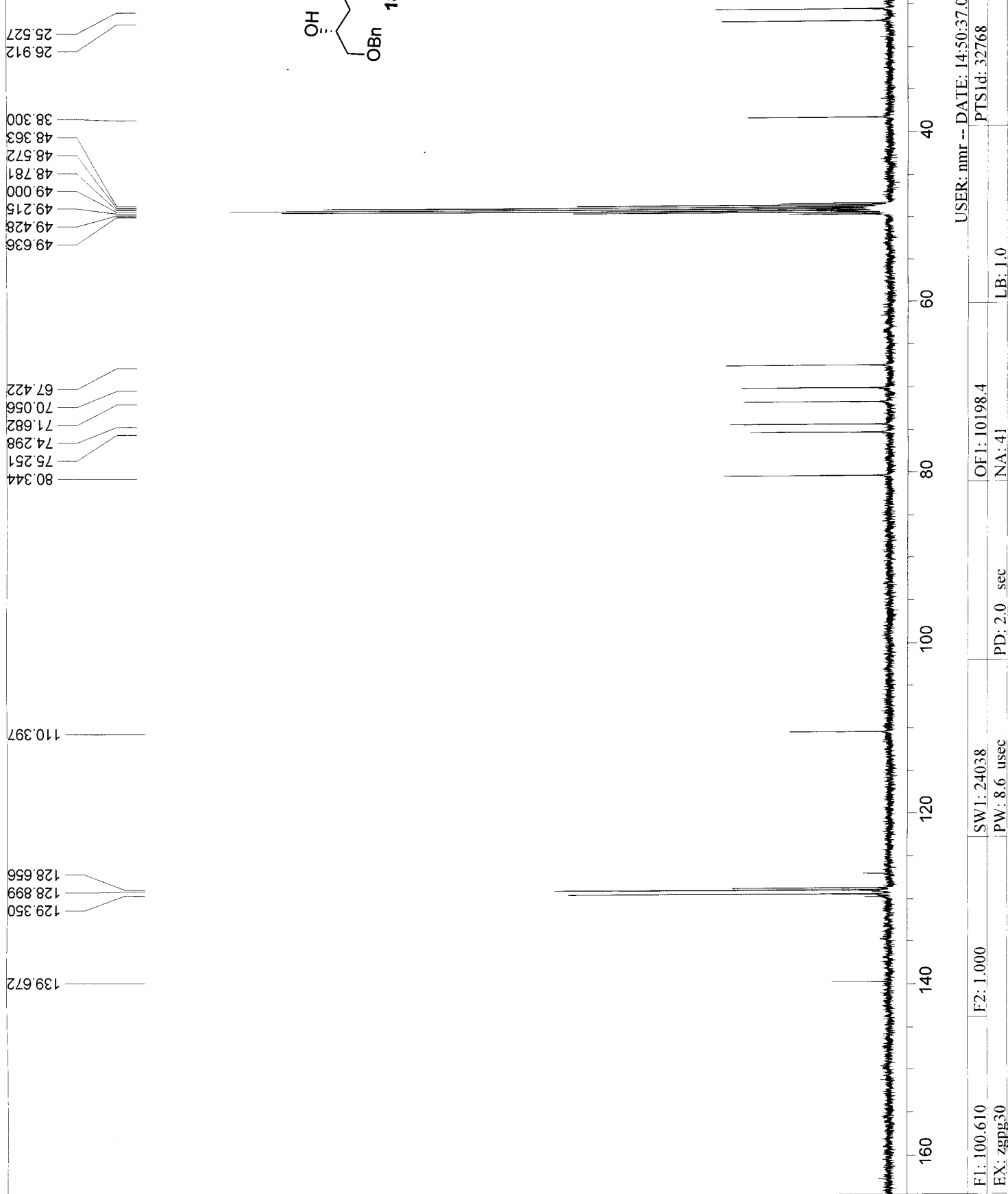
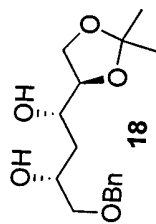

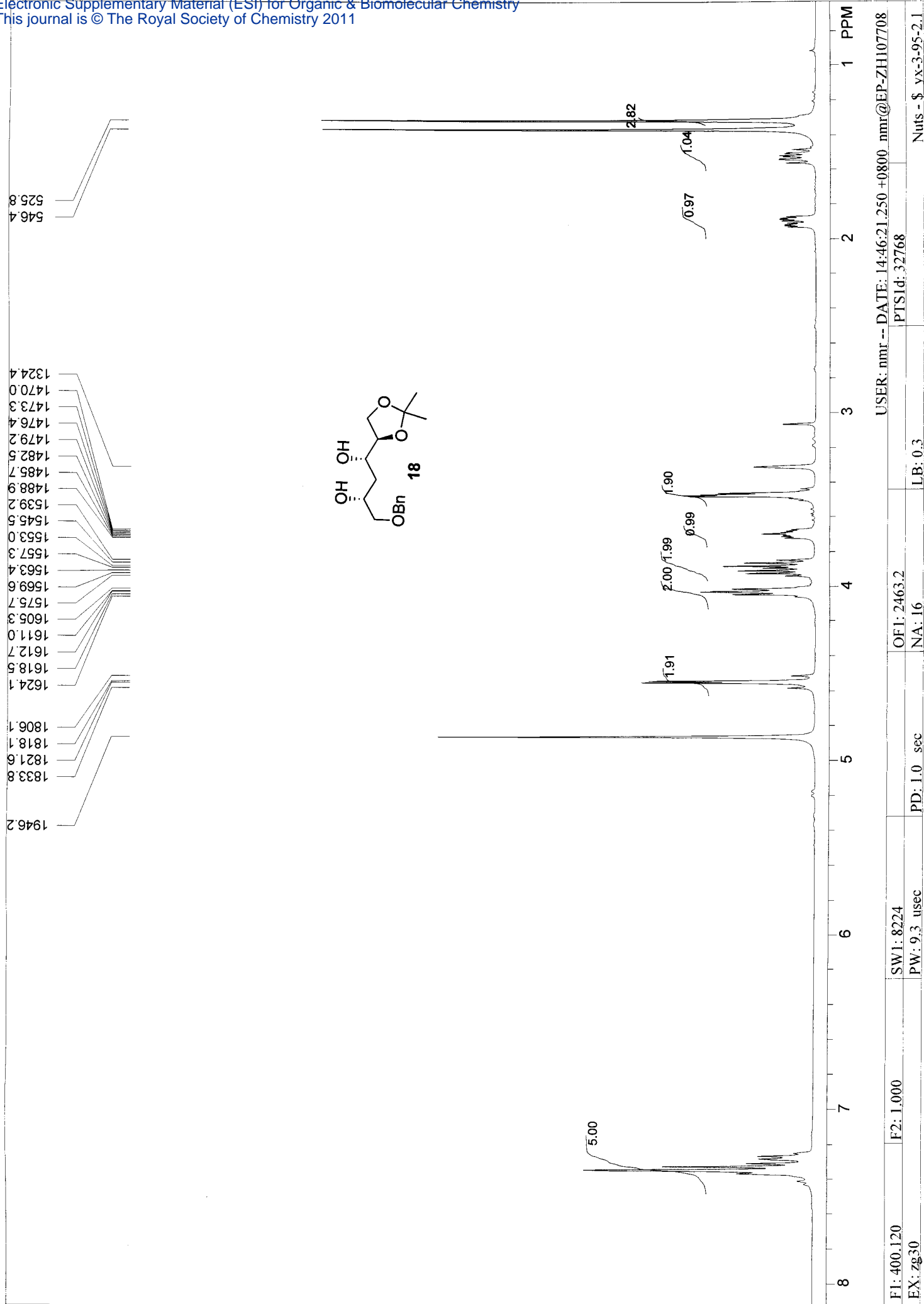

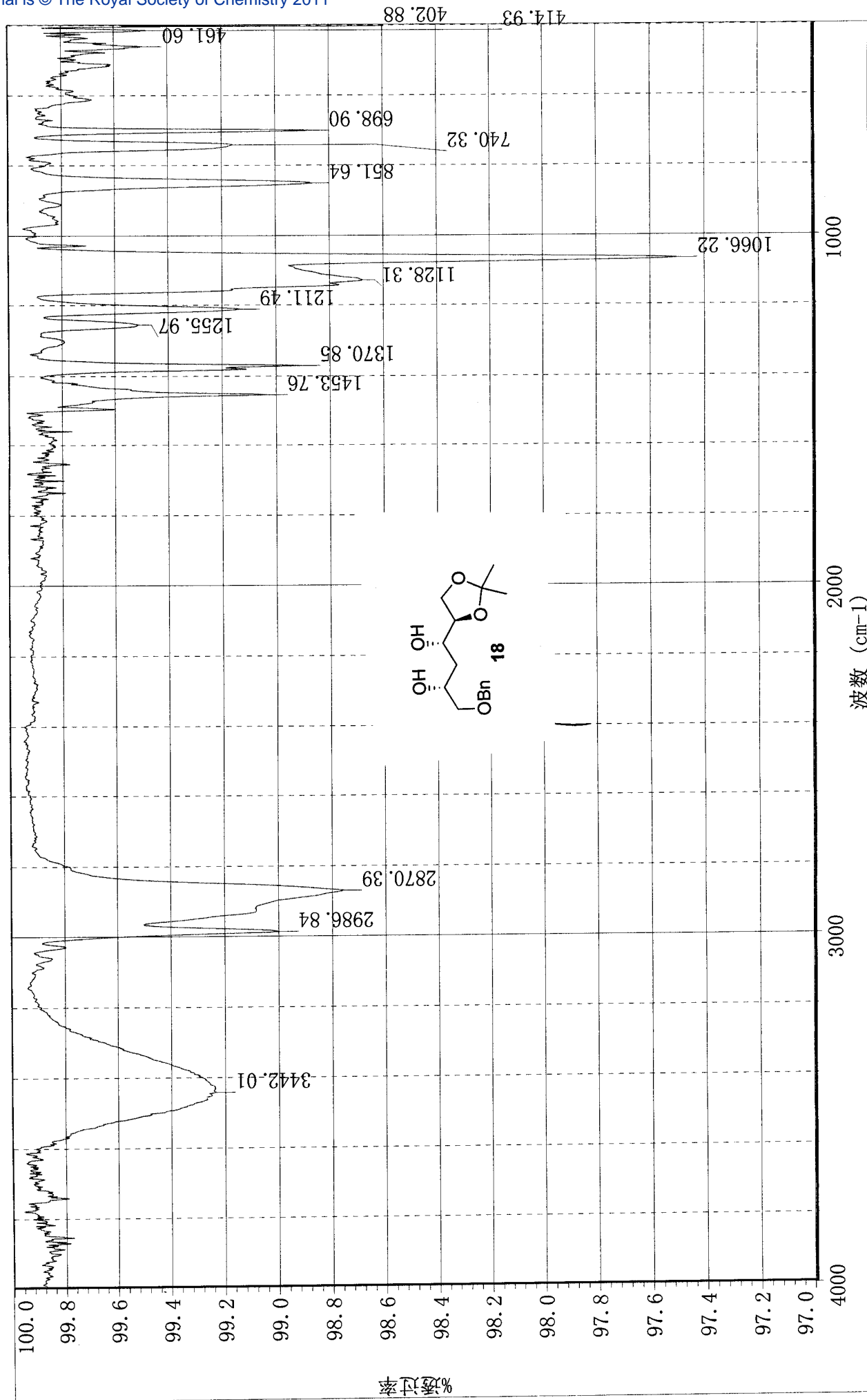

**星期五 5月 13 15:52:51 2011

采集时间: 星期五 5月 13 15:53:32 2011 (GMT+08:00)



上海有机所生命有机化学国家重点实验室

20.932
21.058
25.011
26.188
31.554

65.825
69.880
70.208
70.552
73.067
76.626
76.683
77.000
77.318

109.650

127.540
127.612
128.285

137.786

170.182
170.195

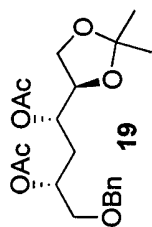

S 52

100 MHz, CDCl₃



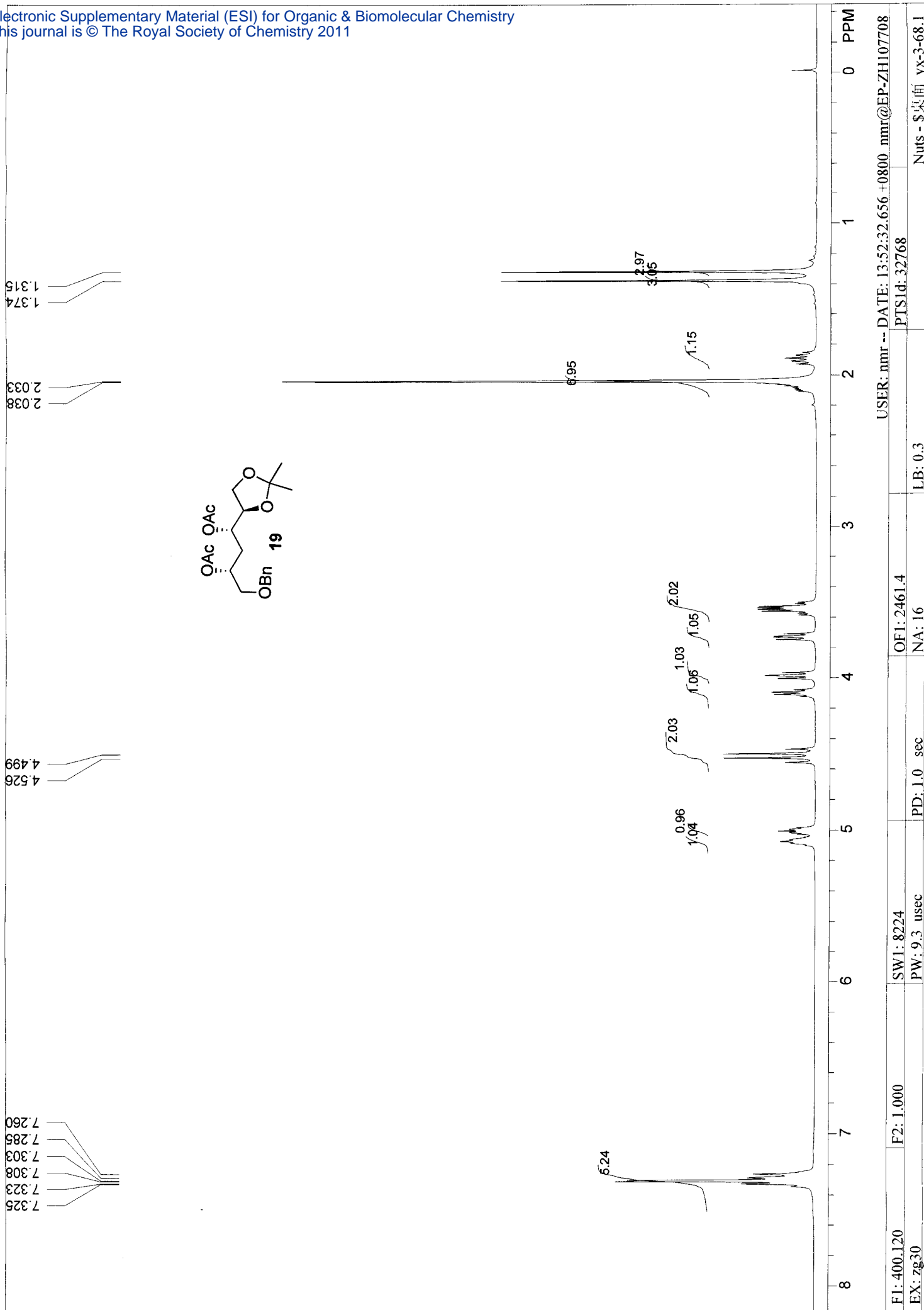

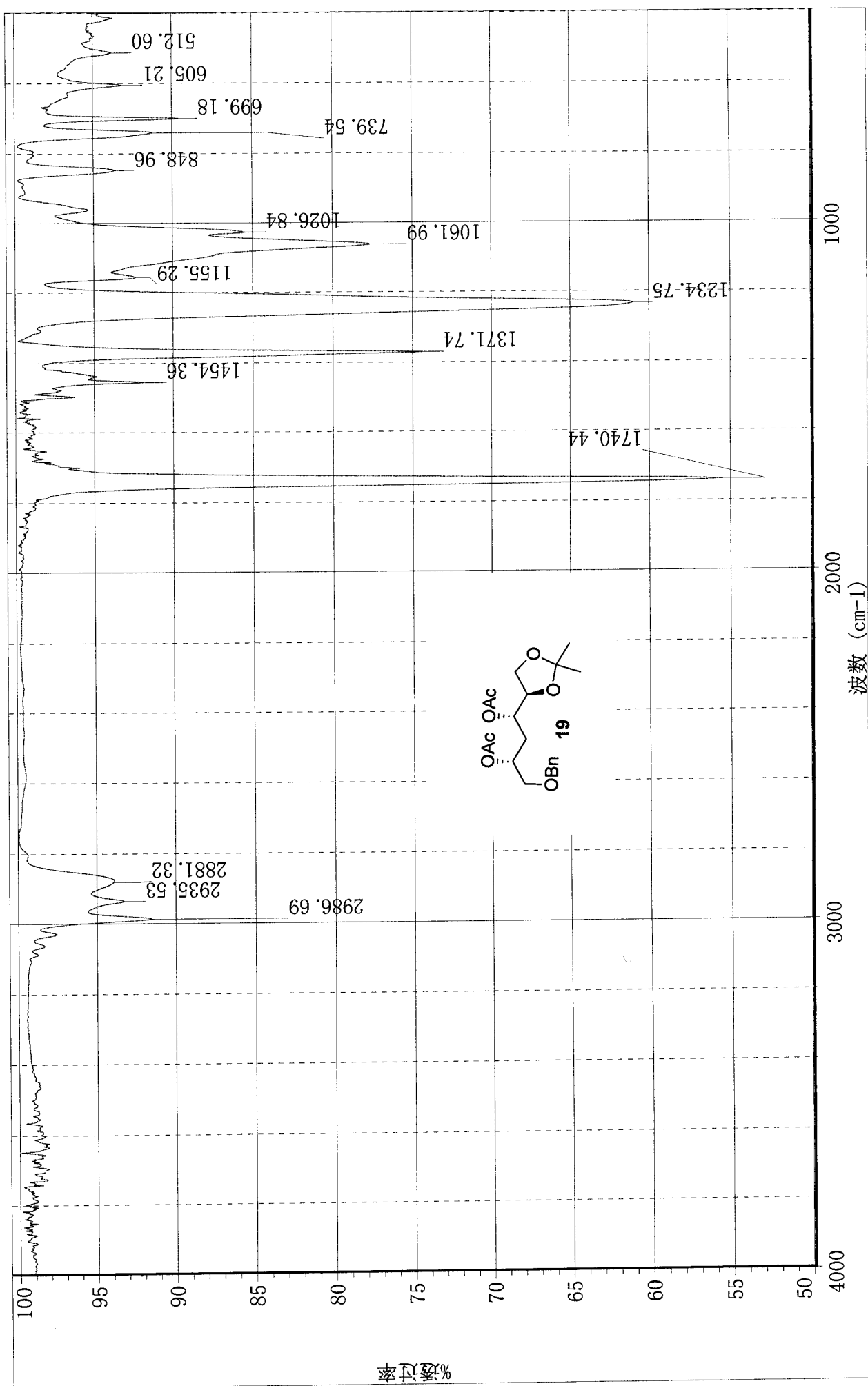

**yx-4-7

采集时间: 星期五 5月 13 16:02:27 2011 (GMT+08:00)



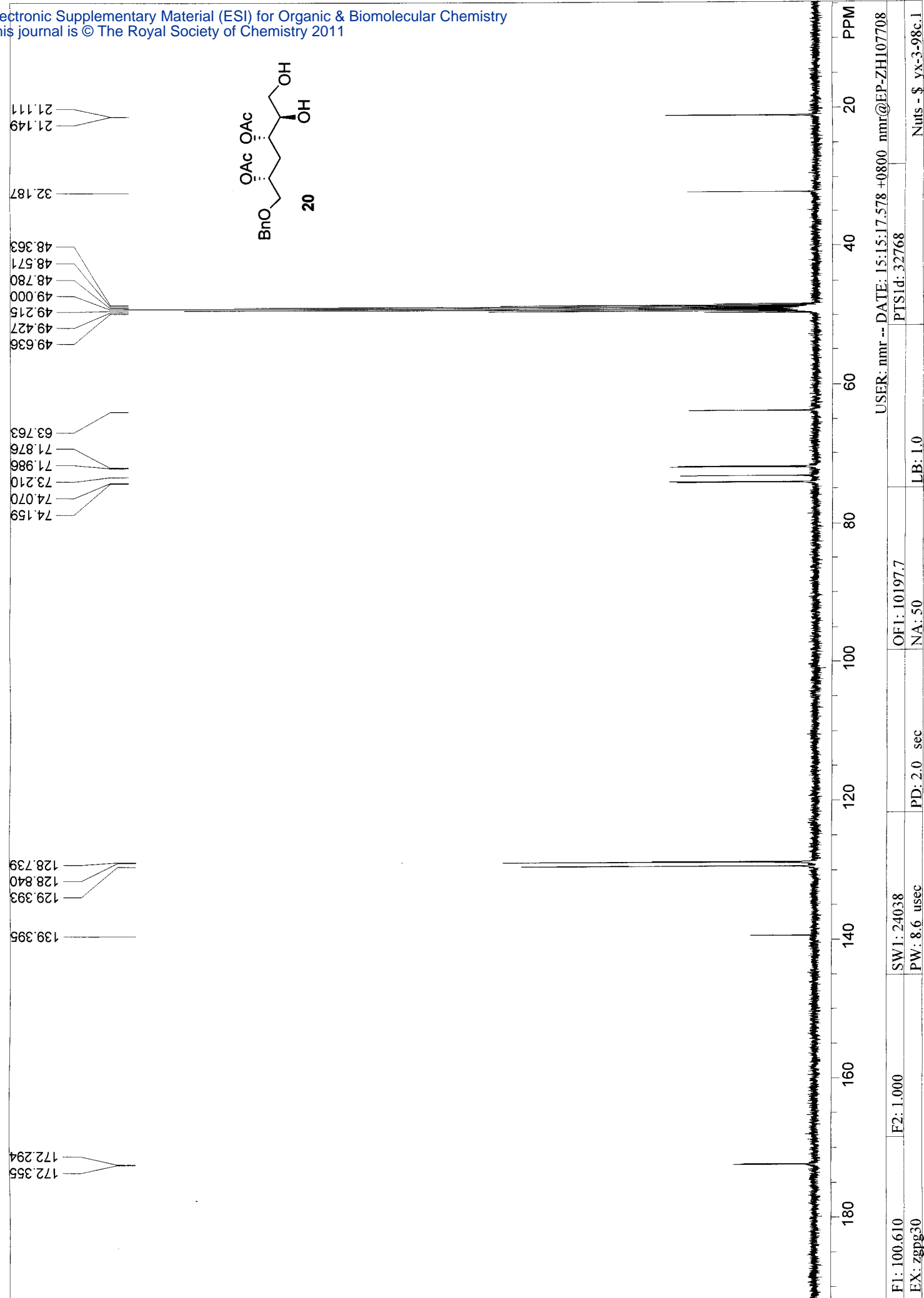

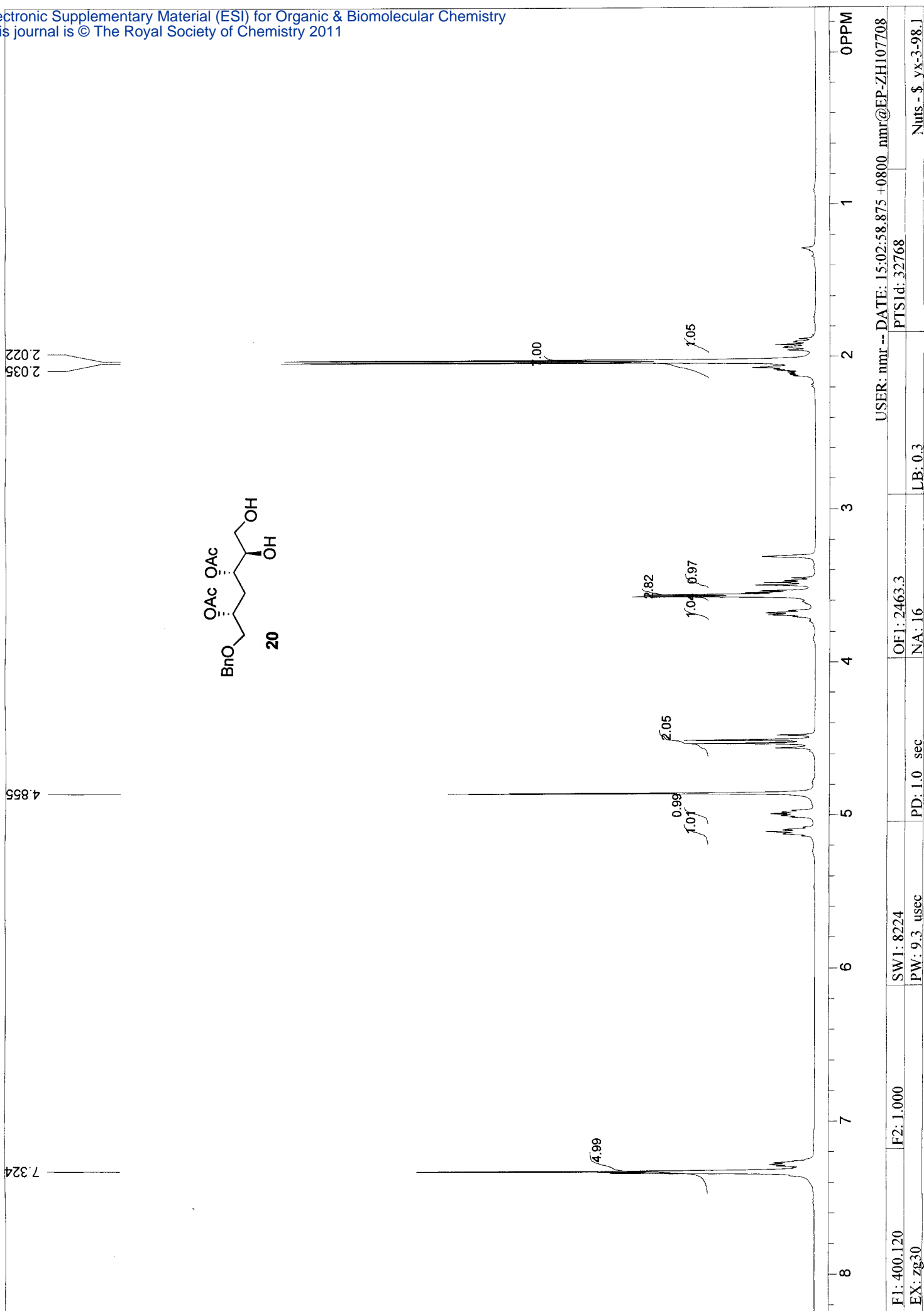

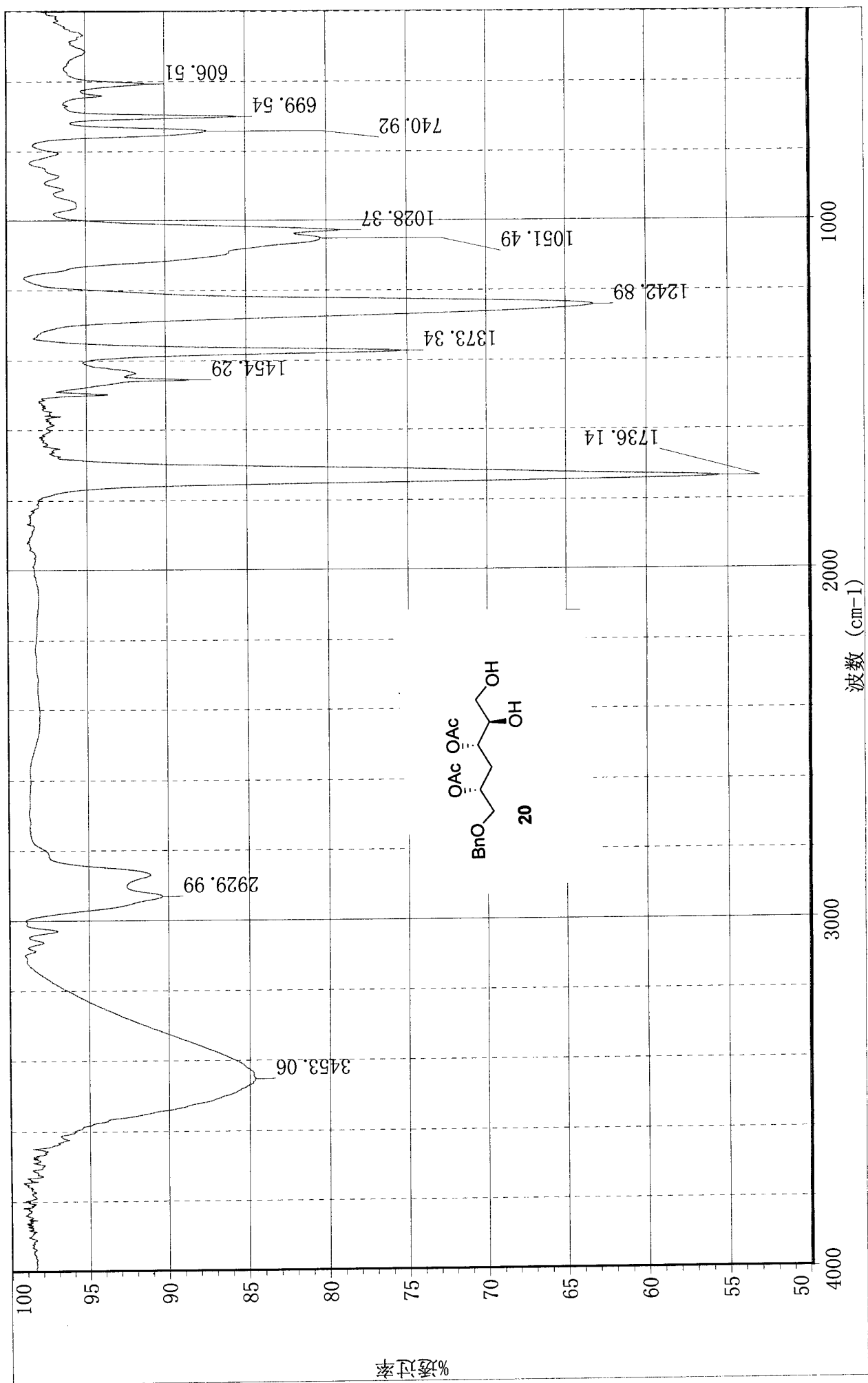

*yx-3-98

采集时间: 星期五 5月 13 16:11:38 2011 (GMT+08:00)

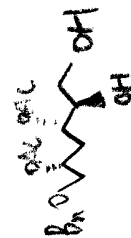

上海有机所生命有机化学国家重点实验室

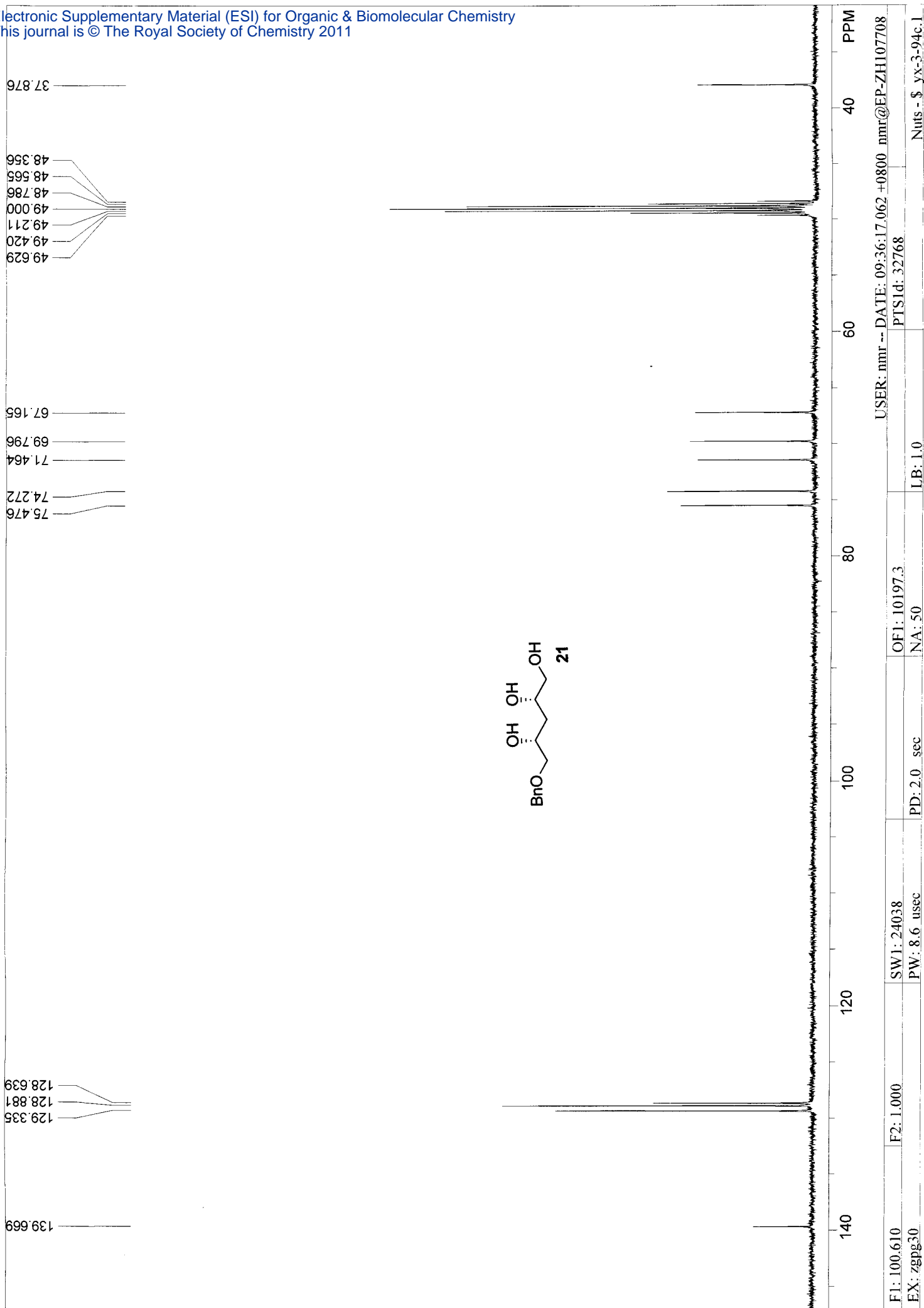

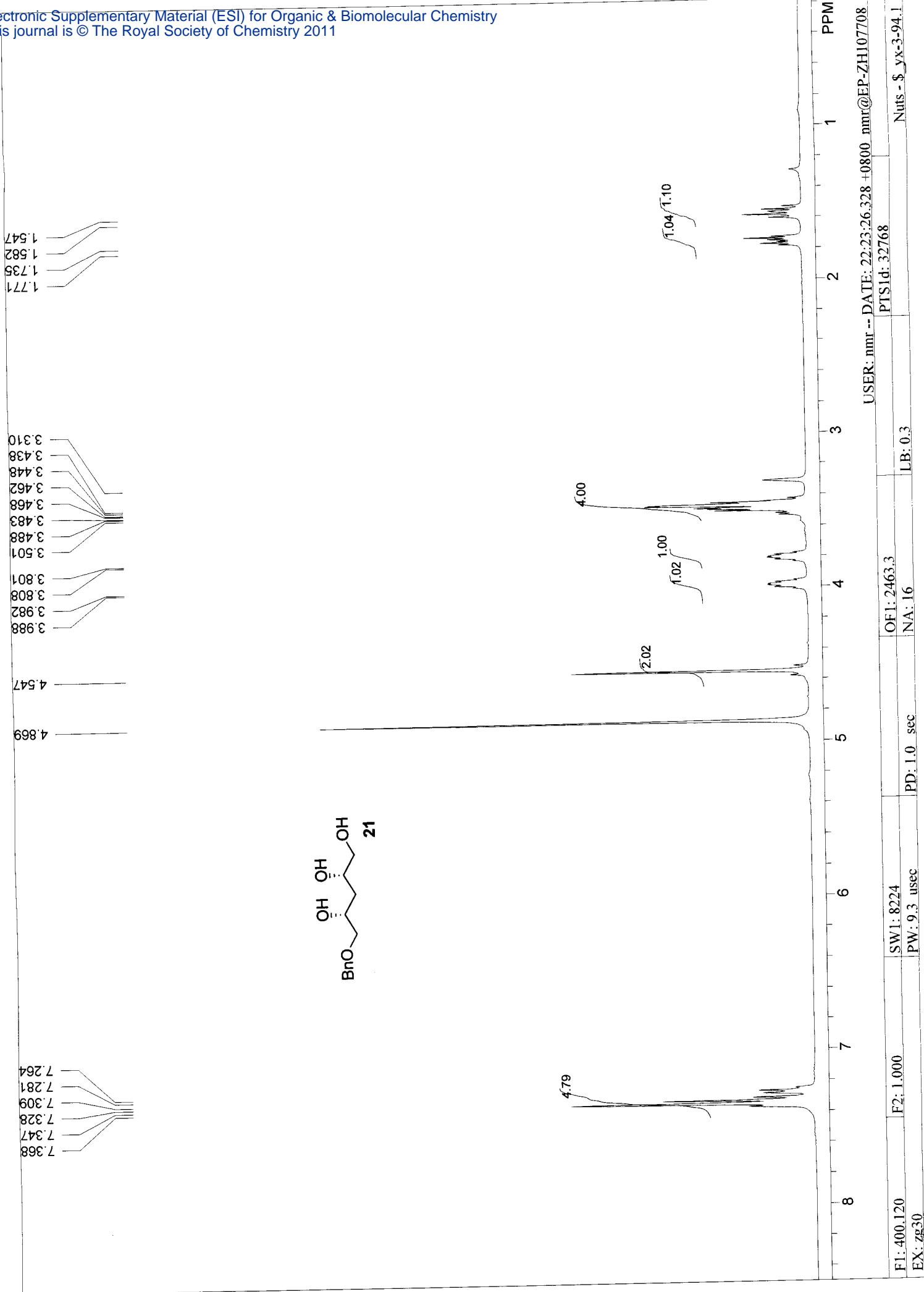

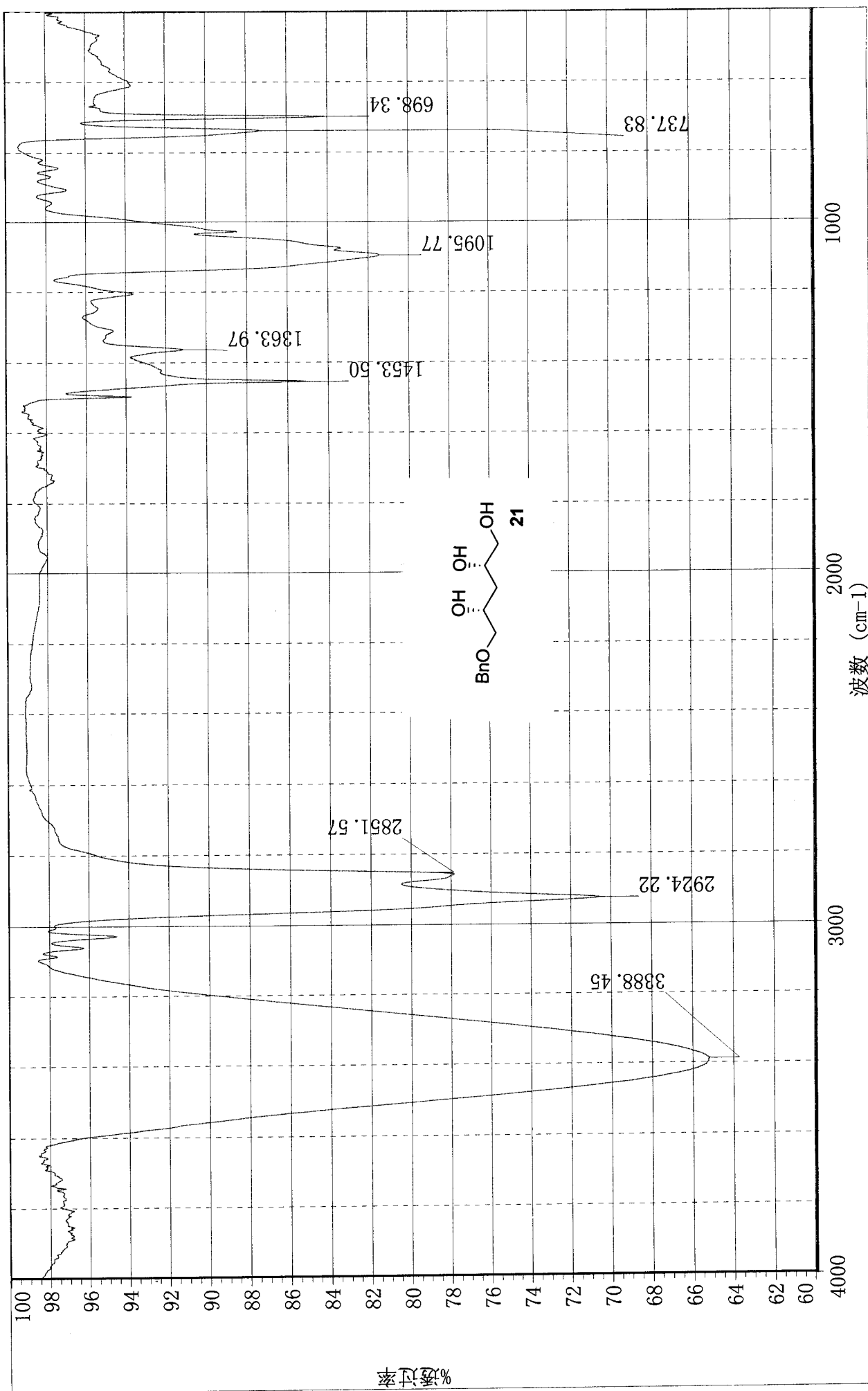

**星期五 5月 13 16:48:48 2011
采集时间: 星期五 5月 13 16:49:29 2011 (GMT+08:00)



上海有机所生命有机化学国家重点实验室

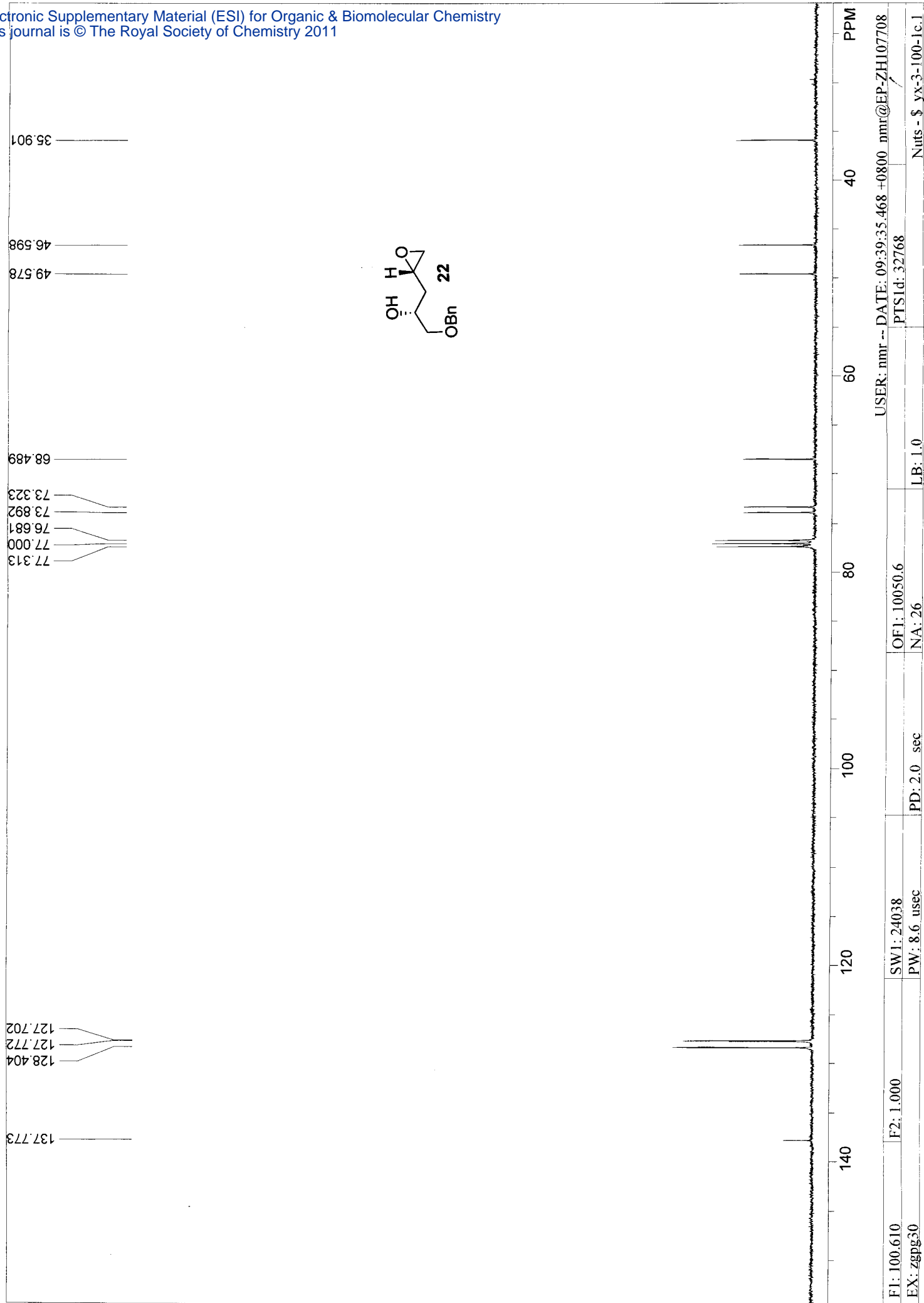

S 61

100 MHz, CDCl₃

4.561

7.338

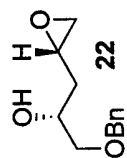

4.85

1.89

0.94

1.95

0.90

0.98

0.86

0.91

1.11

1.00

7

6

5

4

3

2

1

0

PPM

F1: 400.120

F2: 1.000

SW1: 8224

PW: 9.3 usec

PD: 1.0 sec

OF1: 2461.2

NA: 16

LB: 0.3

PTSID: 32768

USER: nmr -- DATE: 14:38:45.437 +0800 nmr@EP-ZH107708

Nuts - \$ _yx-3-100-In.1

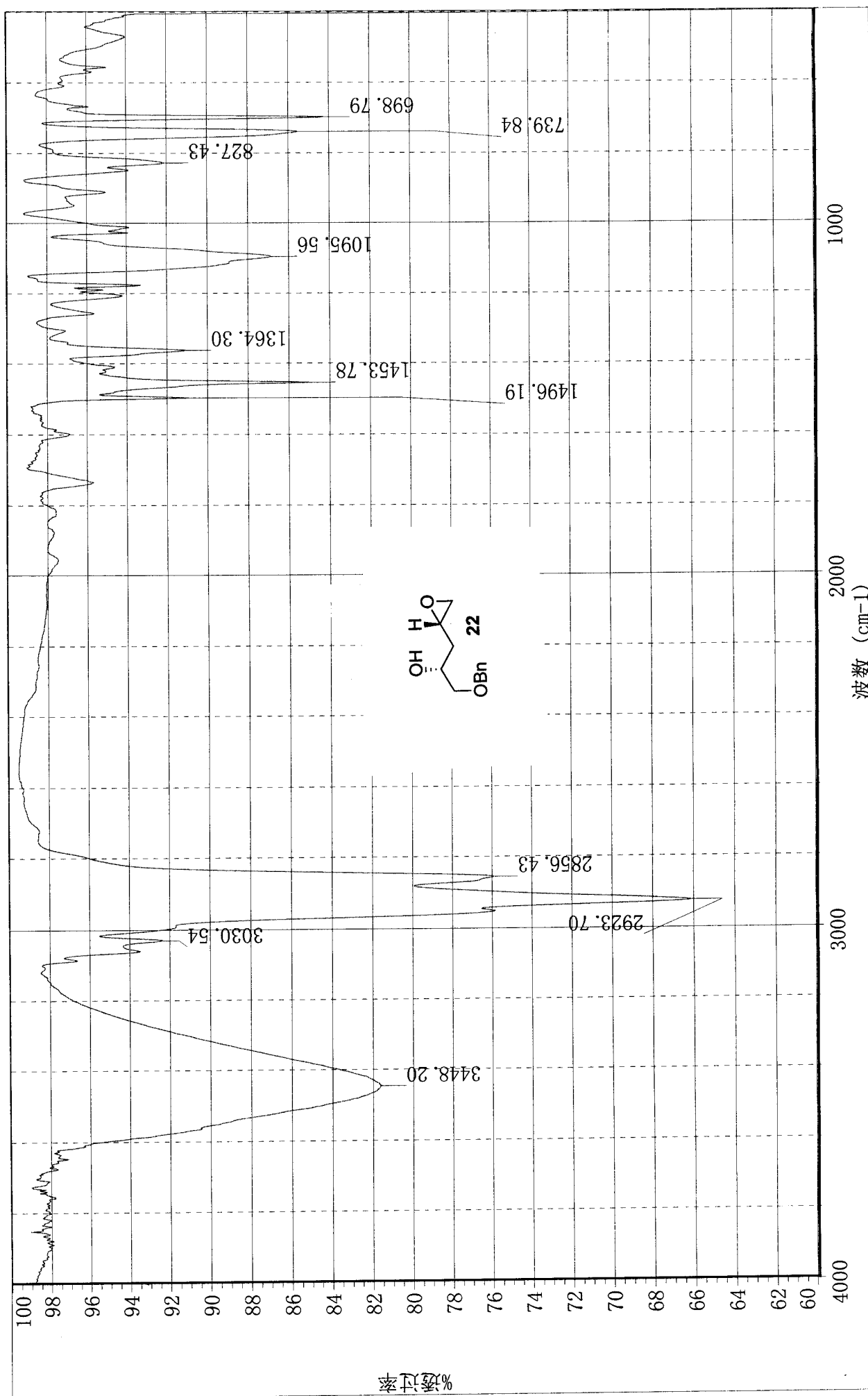

S 93

**星期五 5月 13 16:33:28 2011

采集时间: 星期五 5月 13 16:34:12 2011 (GMT+08:00)

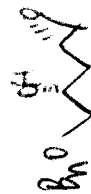

上海有机所生命有机化学国家重点实验室

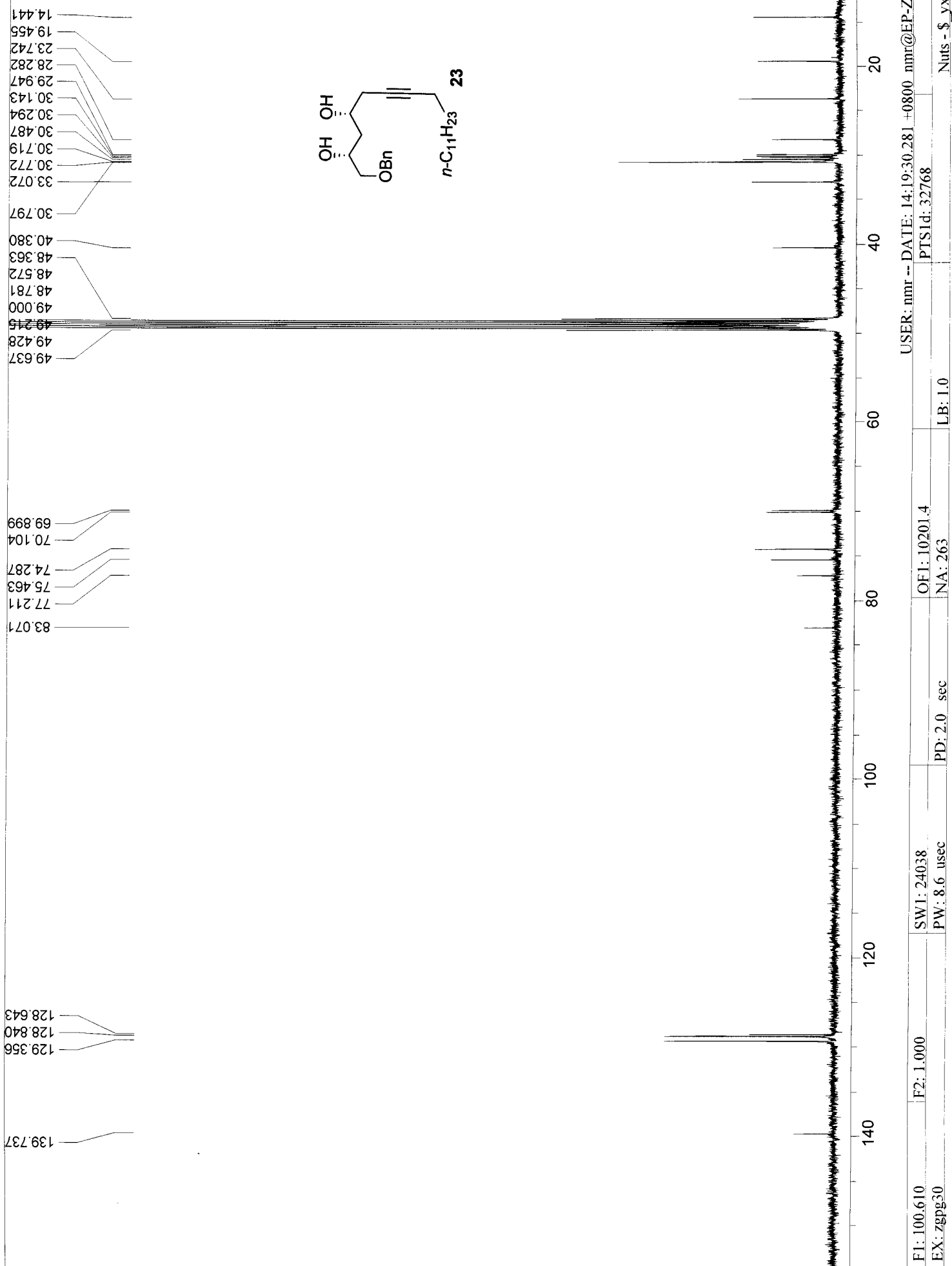

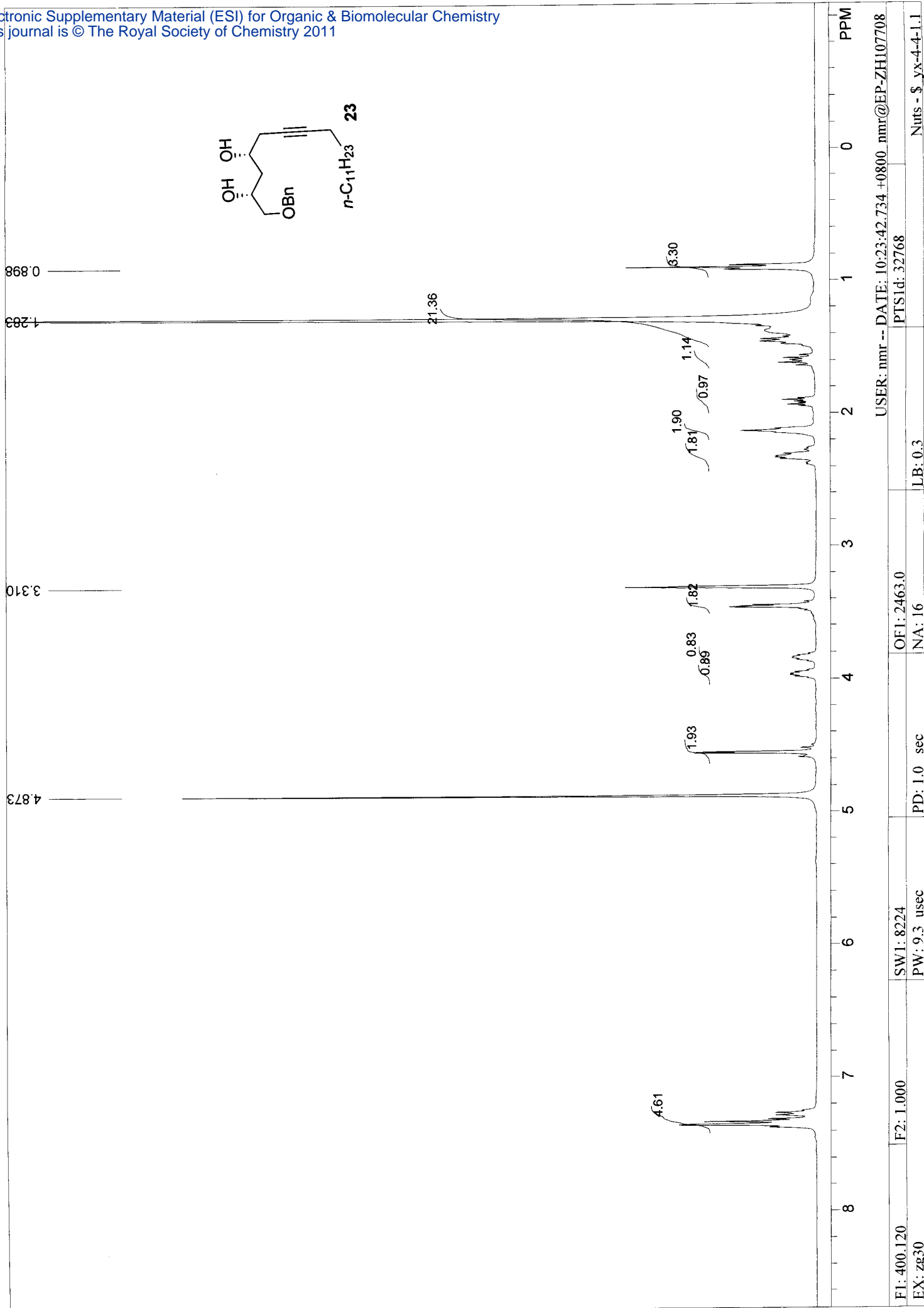

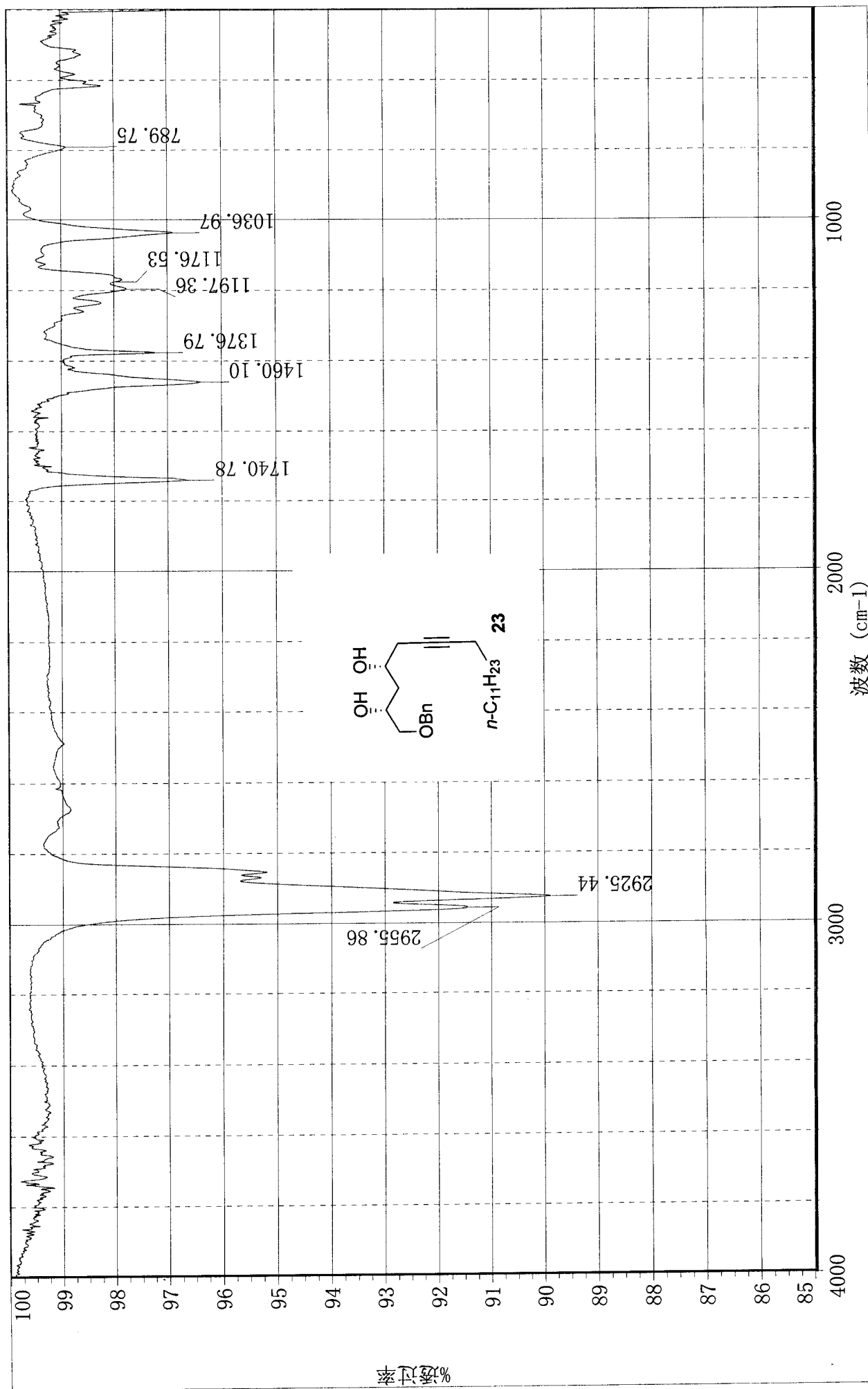

**星期五 5月 13 16:57:50 2011

采集时间: 星期五 5月 13 16:58:31 2011 (GMT+08:00)



上海有机所生命有机化学国家重点实验室

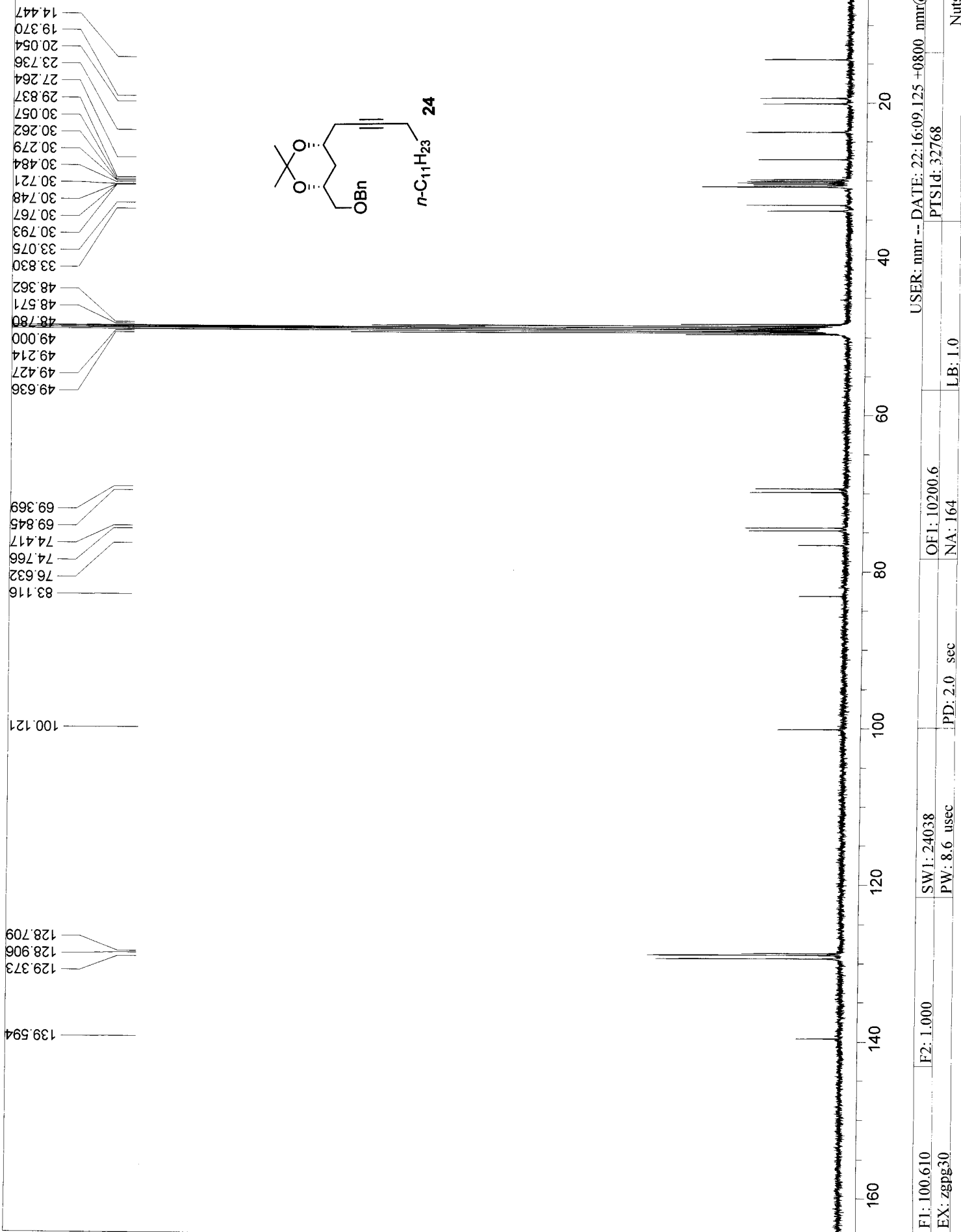

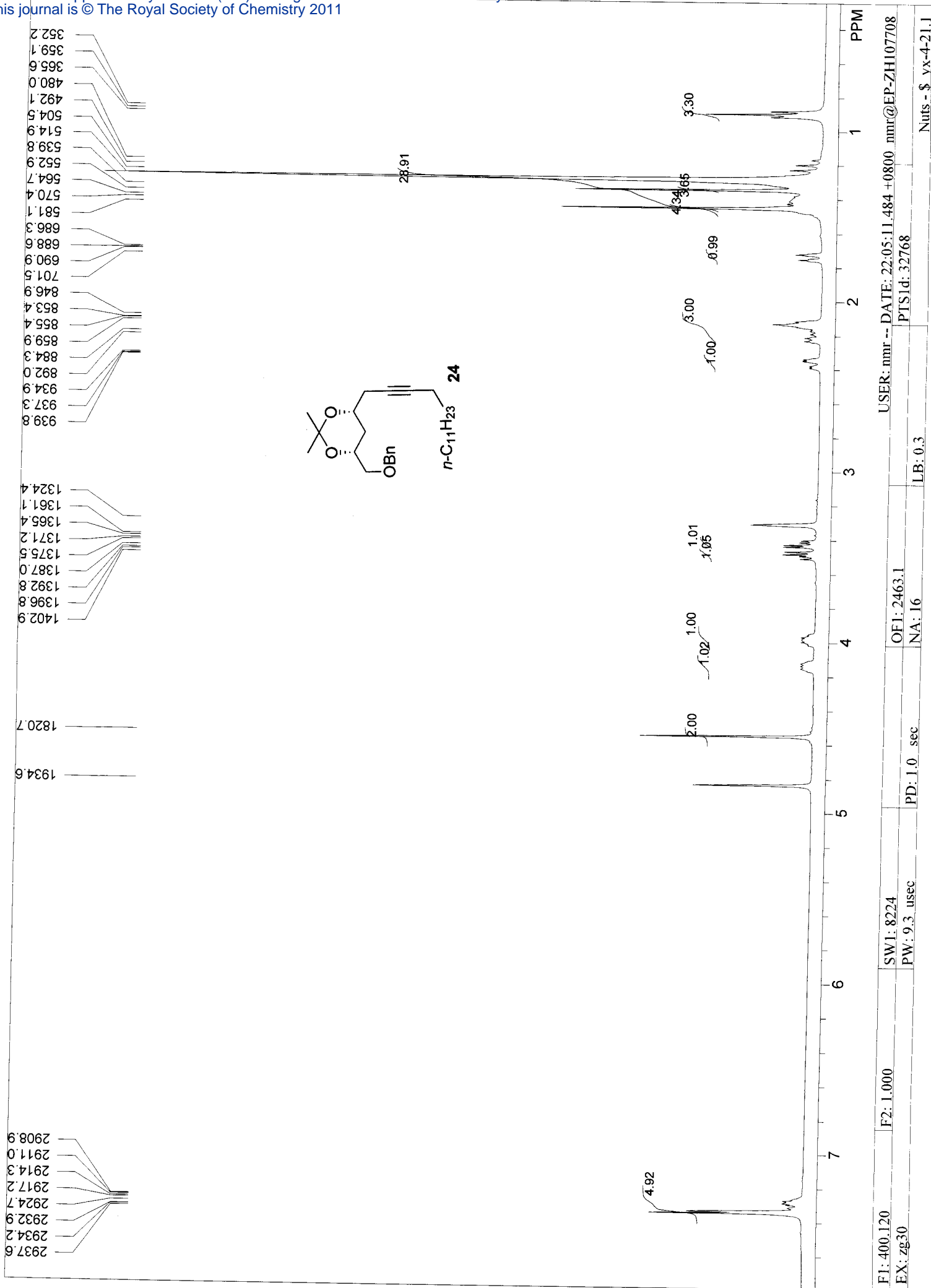

F1: 400.120 F2: 1.000 SW1: 8224
 EX: zg30 PD: 1.0 sec OF1: 2463.1 NA: 16
 USER: mmr -- DATE: 22:05:11.484 +0800 nmr@EP-ZH107708
 PTS1d: 32768 LB: 0.3
 Nuts - \$ _yx-4-21.1

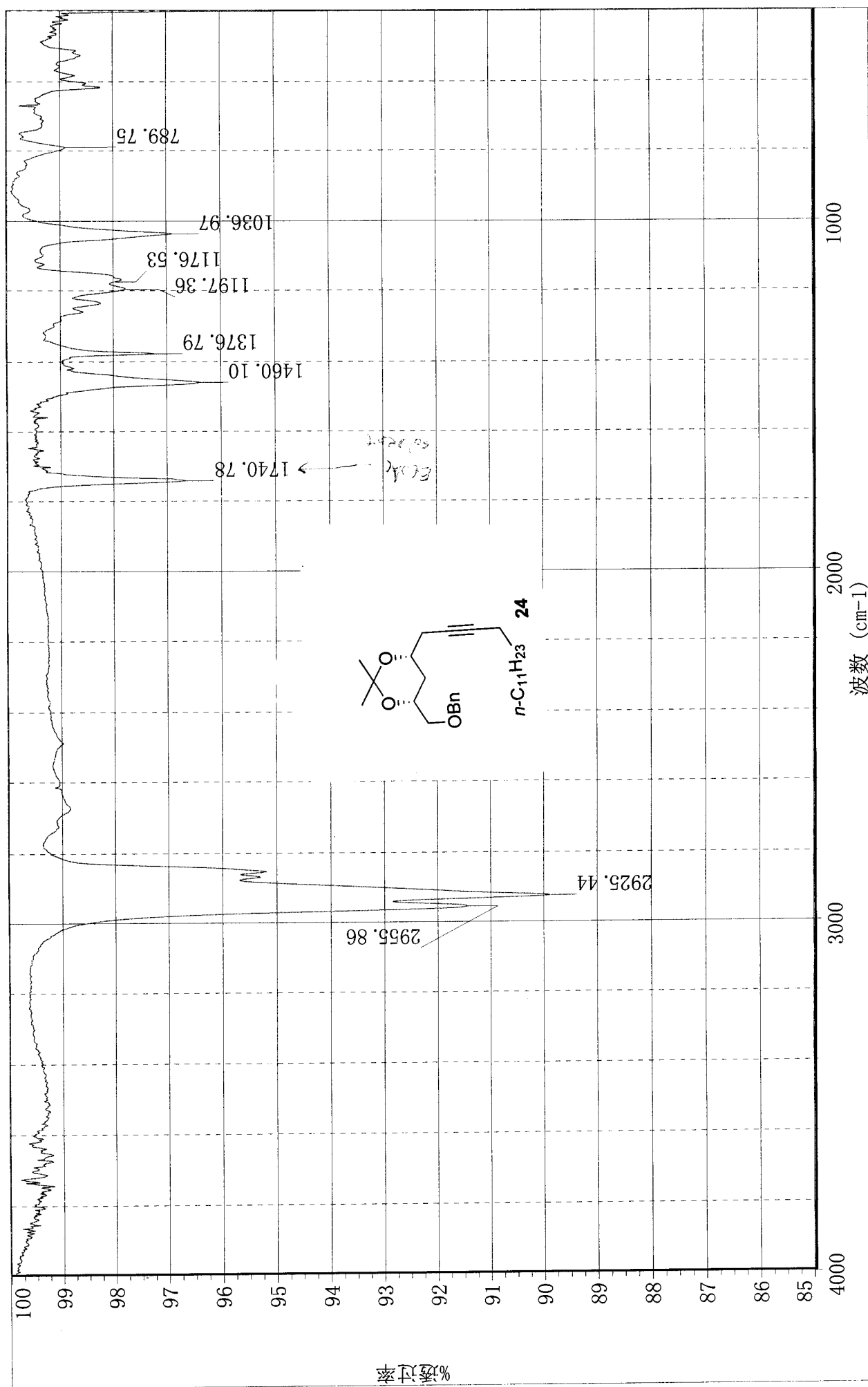

S 69

**星期五 5月 13 16:57:50 2011

采集时间: 星期五 5月 13 16:58:31 2011 (GMT+08:00)



上海有机所生命有机化学国家重点实验室

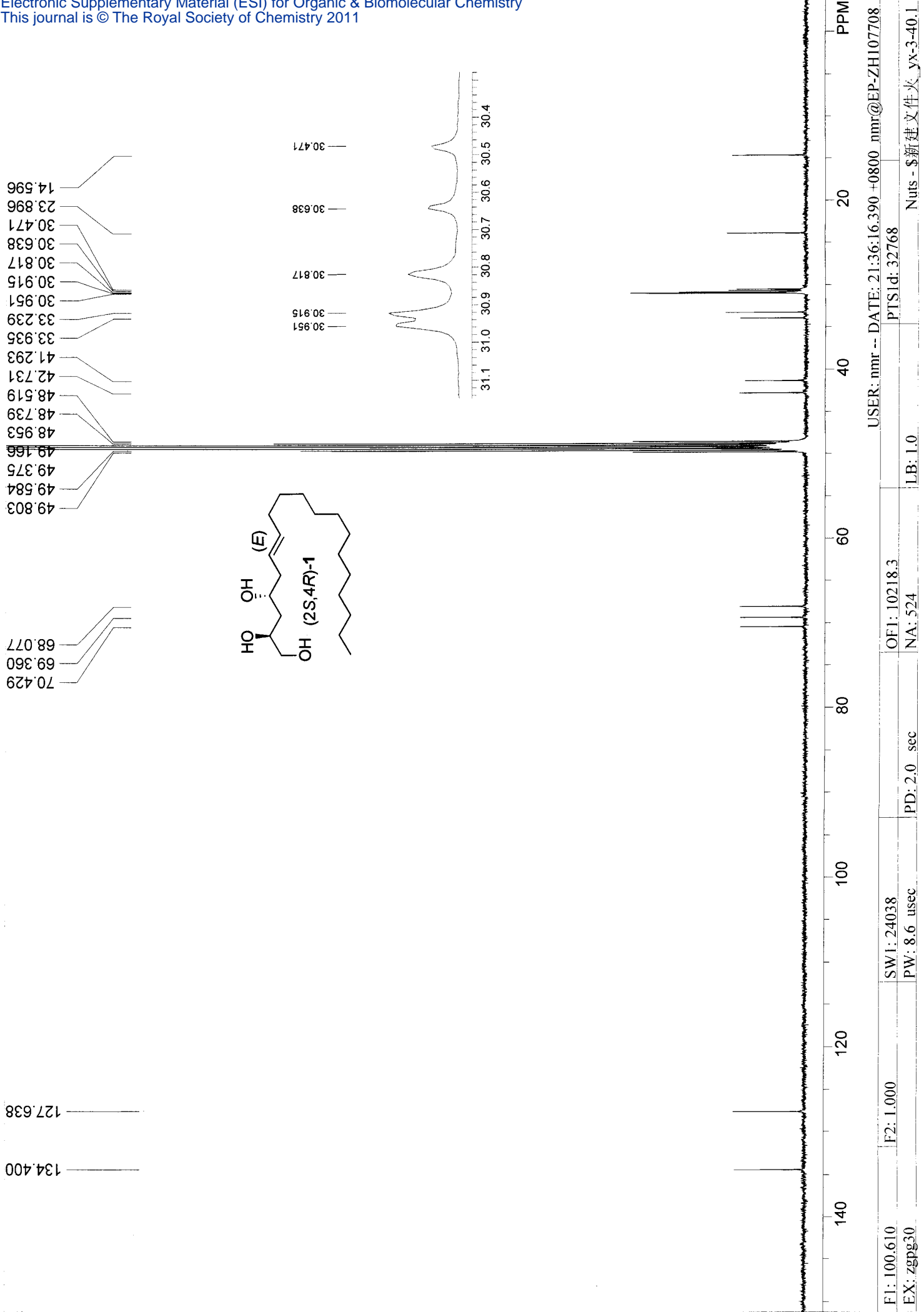

F1: 100.610 F2: 1.000 SW1: 24038 OF1: 10218.3
 EX: zgpg30 PD: 2.0 sec NA: 524 LB: 1.0
 USER: nmr -- DATE: 21:36:16.390 +0800 nmr@EP-ZHI07708
 P1SId: 32768 Nuts - \$新建文件夹_yx-3-40.1

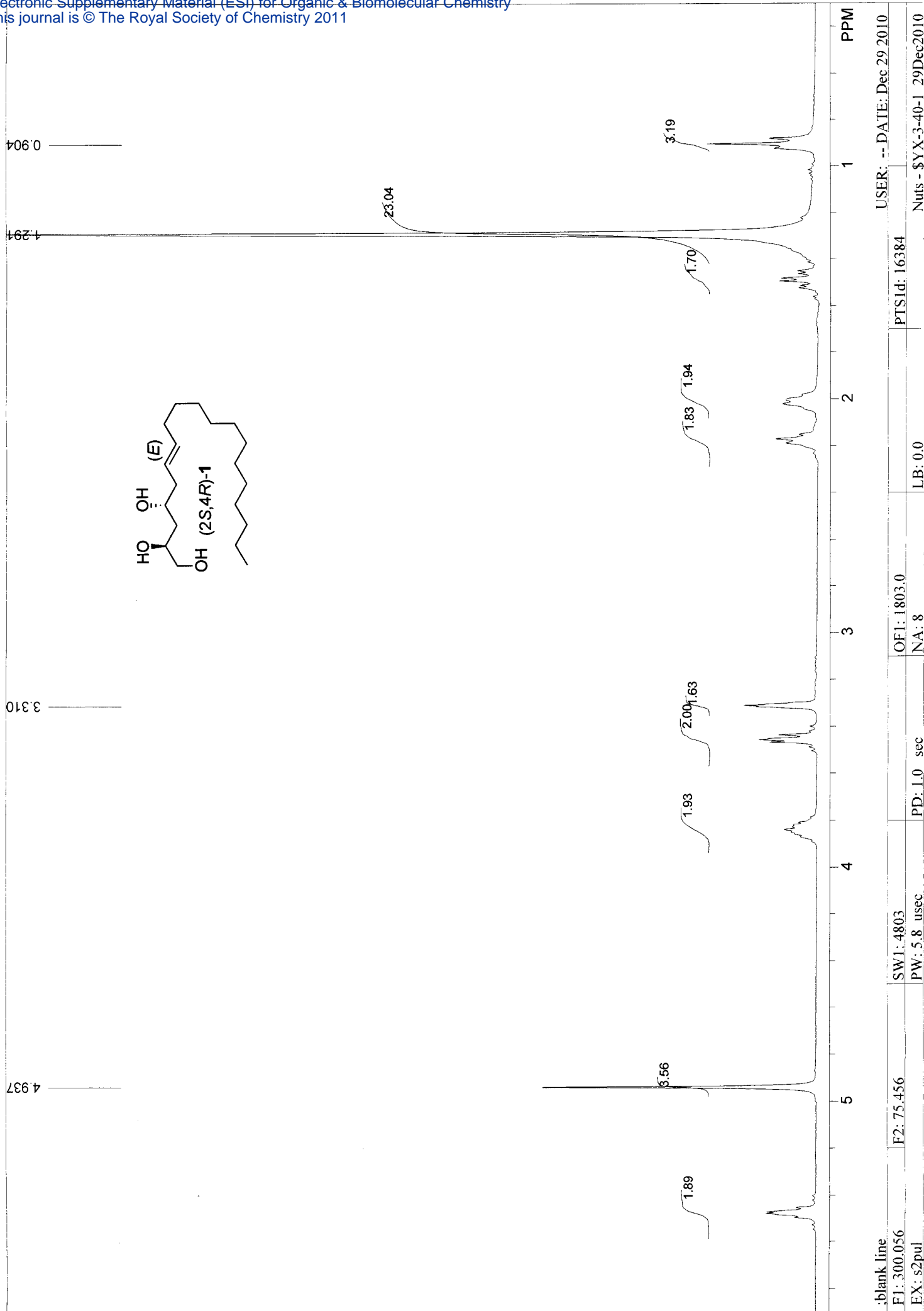

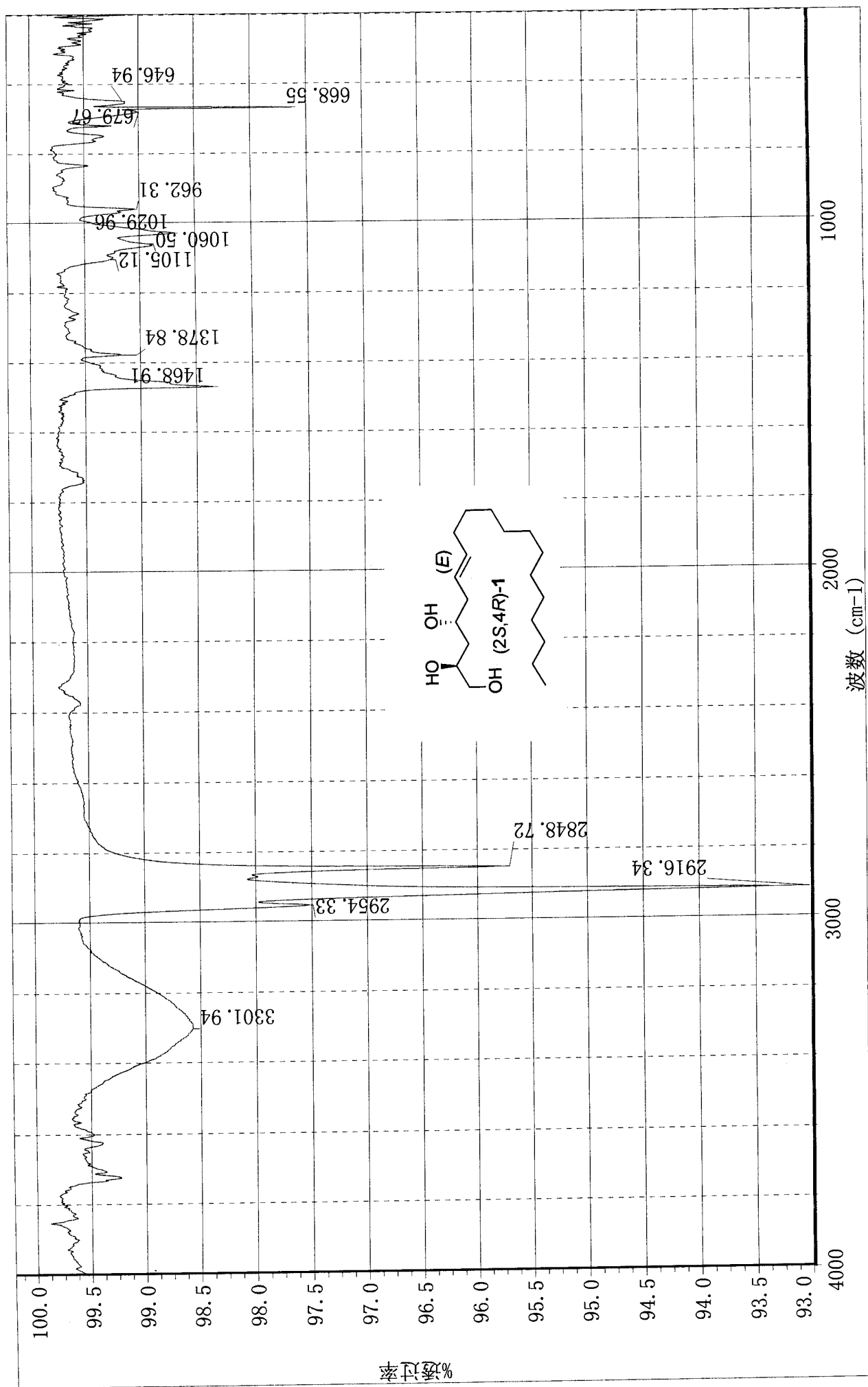

****yx-3-40

采集时间: 星期三 2月 16 09:53:30 2011 (GMT+08:00)



上海有机所生命有机化学国家重点实验室

14.428
23.733
30.290
30.472
30.638
30.759
30.790
33.074
33.755
40.459
41.841
48.353
48.571
48.786
49.000
49.209
49.418
49.635

67.240
71.200
72.090

127.211
134.404

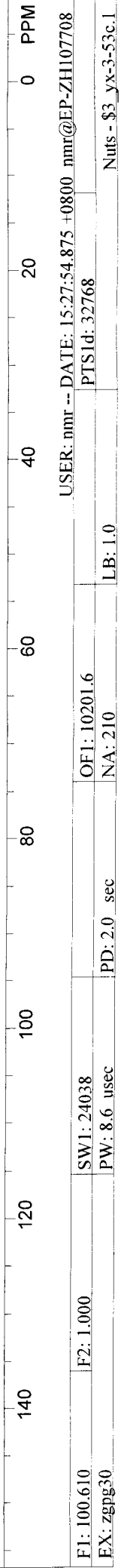
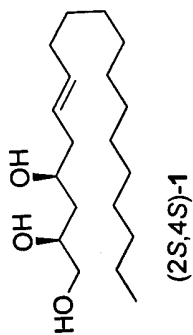

F1: 100.610 F2: 1.000 SW1: 24038
EX: zgpg30 PD: 2.0 sec NA: 210 OF1: 10201.6 LB: 1.0
USER: nmr -- DATE: 15:27:54.875 +0800 nmr@EP-ZH1107708
PTSID: 32768 Nuts - \$3_yx-3-53c.1

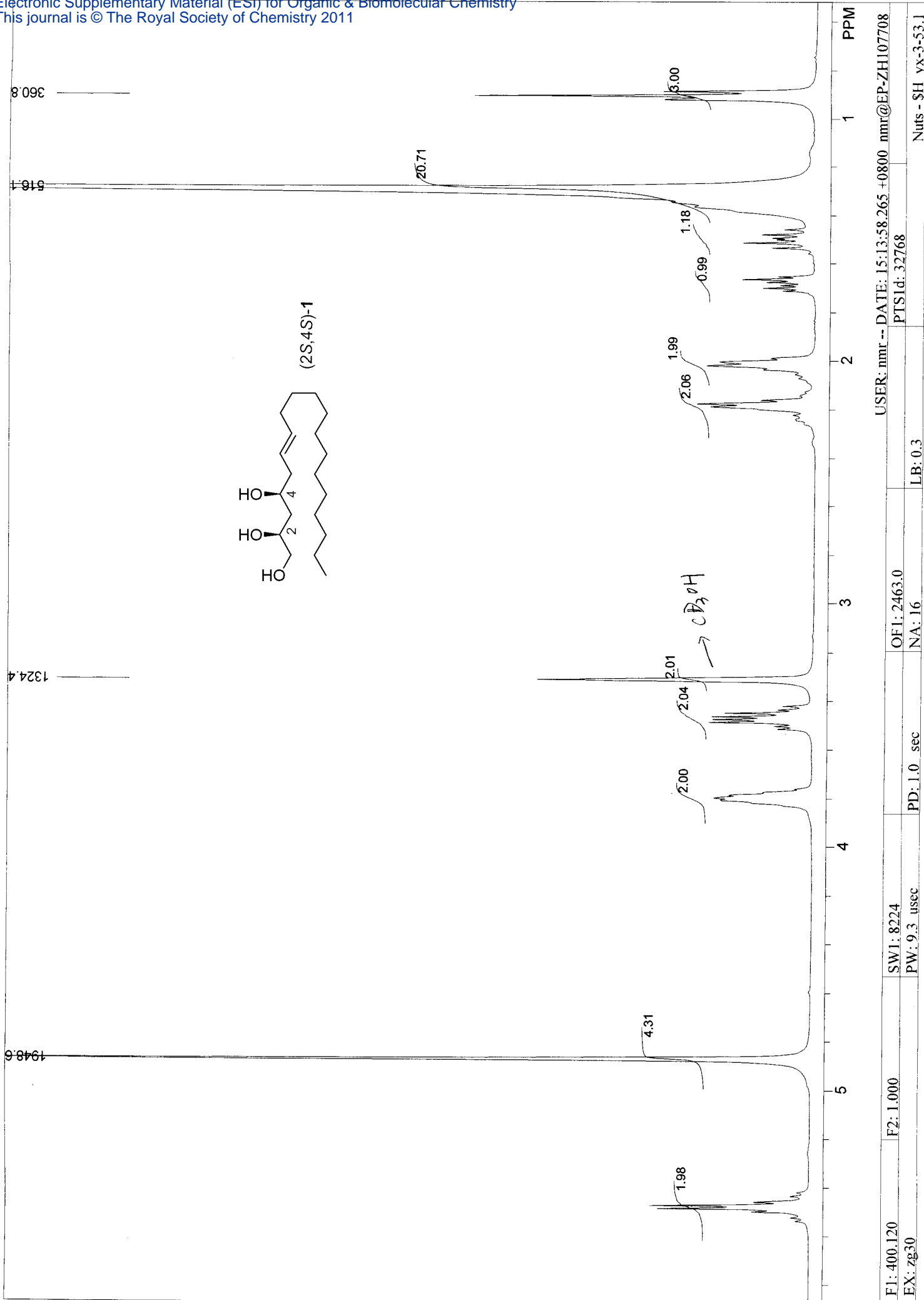

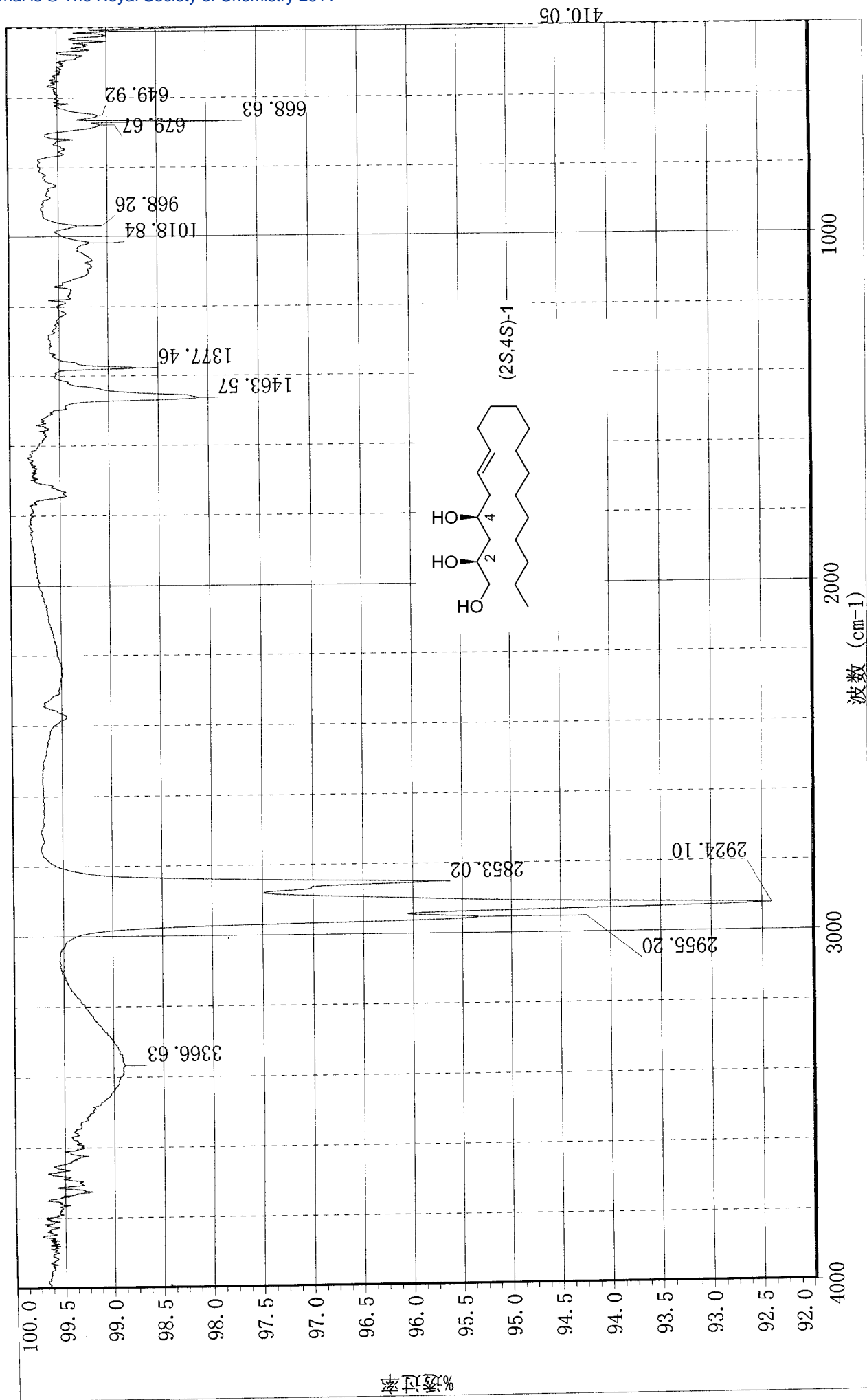

S 75

*yx-3-53

采集时间: 星期三 2月 16 10:11:36 2011 (GMT+08:00)



上海有机所生命有机化学国家重点实验室

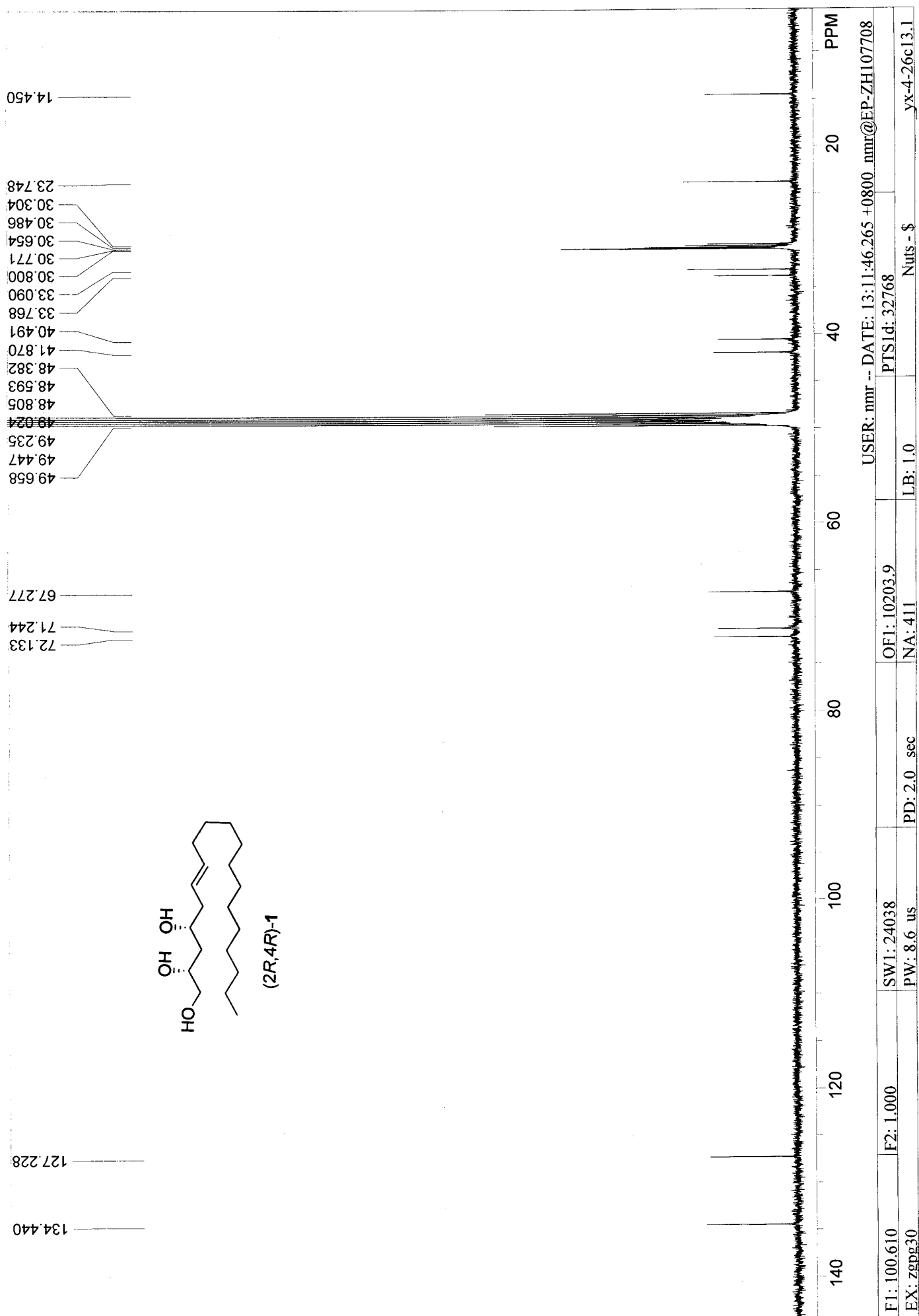

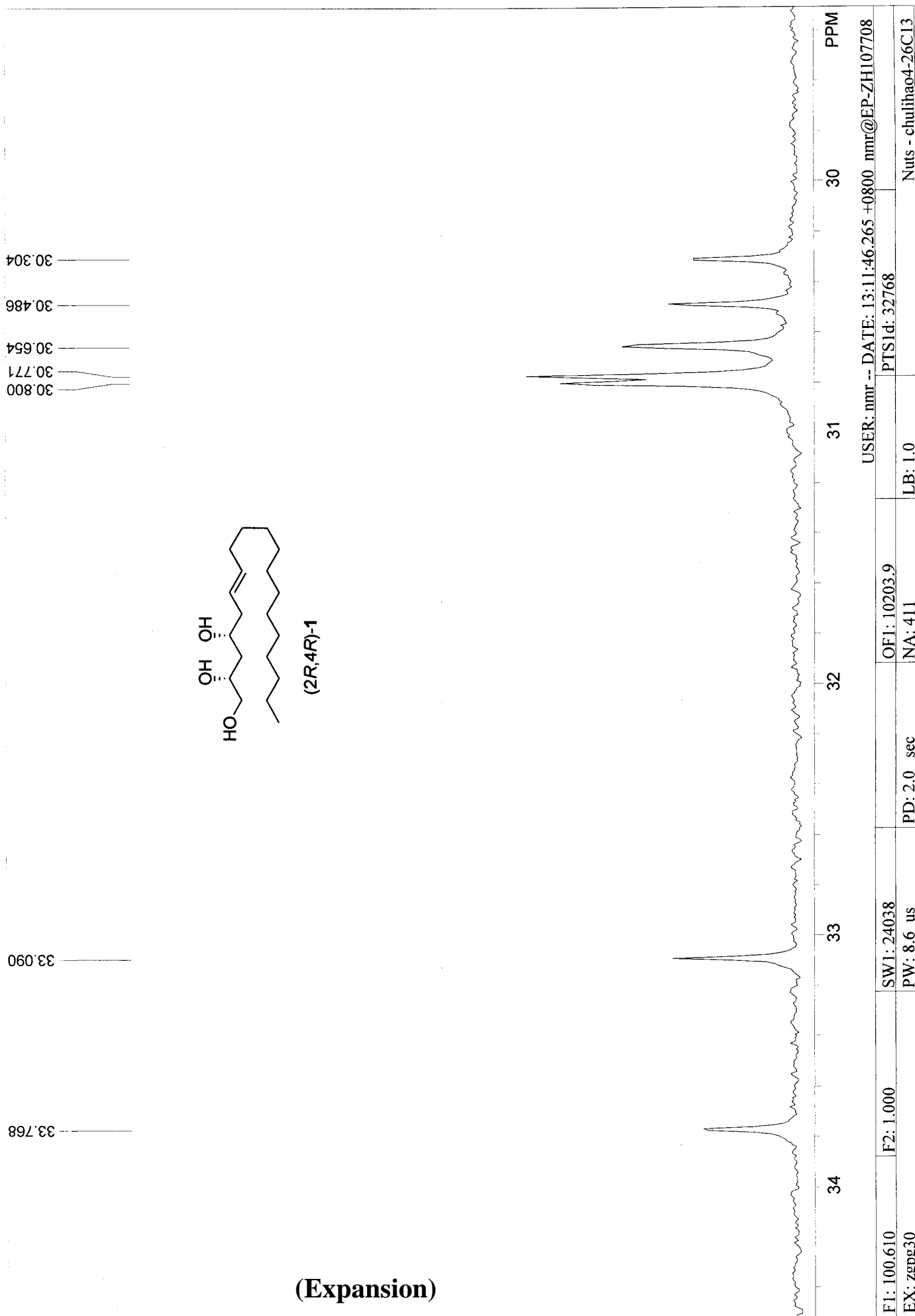

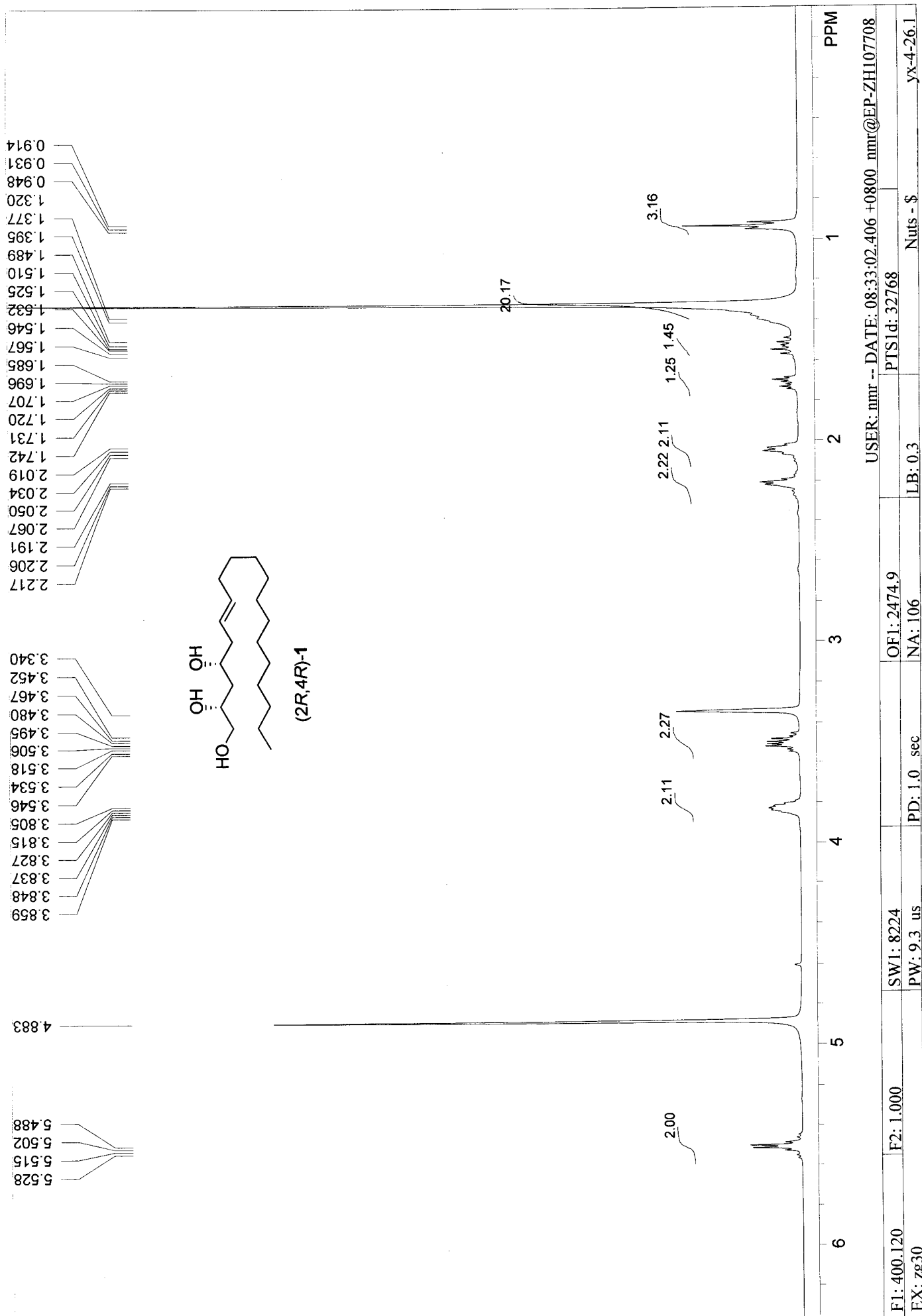

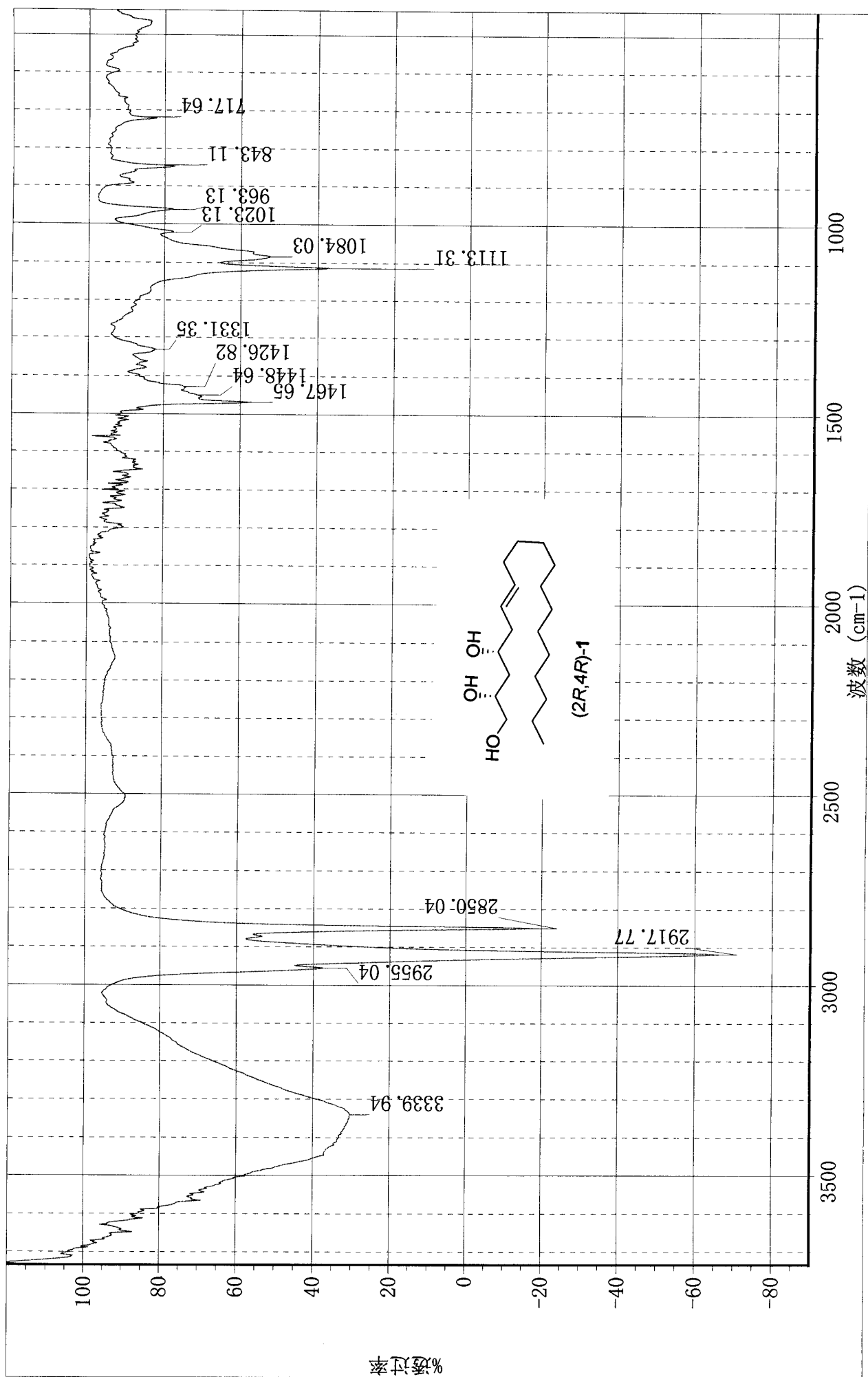

yx-4-26KBr

采集时间: 星期二 5月 31 21:56:37 2011 (GMT+08:00)

上海有机所生命有机化学国家重点实验室

Tabular data comparison between the natural **-1** and synthetic (2*R*,4*R*)-**1**

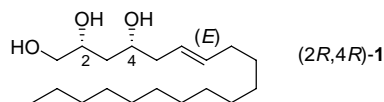

Table S-1. ¹H NMR data comparison

Natural 1 (CD ₃ OD, 500 MHz) ^a	(2 <i>R</i> ,4 <i>R</i>)- 1 (400 MHz, CD ₃ OD)
5.50 (dt, <i>J</i> = 15, 6 Hz, 1H, H-7)	5.52 (dt, <i>J</i> = 15.4, 6.8 Hz, 1H)
5.45 (dt, <i>J</i> = 15, 6 Hz, 1H, H-6)	5.49 (dt, <i>J</i> = 15.3, 6.0 Hz, 1H)
3.80 (m, 1H, H-2)	3.86-3.81 (m, 2H)
3.78 (m, 1H, H-4)	
3.49 (dd, <i>J</i> = 11, 5 Hz, 1H, H-1b)	3.55-3.45 (m, 2H)
3.44 (dd, <i>J</i> = 11, 6Hz, 1H, H-1a)	
2.17 (m, 2H, H-5)	2.22-2.19 (m, 2H)
2.01 (m, 2H, H-8)	2.07-2.02 (m, 2H)
1.68 (dt, <i>J</i> = 14, 4 Hz, 1H, H-3b)	1.71 (dt, <i>J</i> = 14.0, 4.4 Hz, 1H)
1.50 (dt, <i>J</i> = 14, 8 Hz, 1H, H-3a)	1.53 (dt, <i>J</i> = 14.3, 6.5 Hz, 1H)
(not given)	1.38-1.30 (m, 20H)
0.9 (t, <i>J</i> = 7 Hz, 3H, H-19)	0.93 (t, <i>J</i> = 6.8 Hz, 3H)

^aTaken from: F. Abe, S. Nagafuji, M. Okawa, J. Kinjo, H. Akahane, T. Ogura, M. A. Martinez-Alfaro and R. Reys-Chilpa, *Biol. Parm. Bull.*, 2005, **28**, 1314. ^bThis work.

Table S-2. ¹³C NMR data comparison

Natural -1 (CD ₃ OD, 500 MHz) ^a	(2 <i>R</i> ,4 <i>R</i>)- 1 (400 MHz, CD ₃ OD) ^b
134.4 (C-6)	134.4
127.2 (C-7)	127.2
72.2 (C-2)	72.1
71.3 (C-4)	71.2
67.3 (C-1)	67.3
41.9 (C-5)	41.9
40.5 (C-3)	40.5
33.7 (C-8)	33.8
33.0 (C-17)	33.1
30.3~30.8 (C-9 to C-16)	30.80, 30.77, 30.6, 30.5, 30.3
23.3 (C-18)	23.7
14.4 (C-19)	14.4

^aTaken from: F. Abe, S. Nagafuji, M. Okawa, J. Kinjo, H. Akahane, T. Ogura, M. A. Martinez-Alfaro and R. Reys-Chilpa, *Biol. Parm. Bull.*, 2005, **28**, 1314. ^bThis work.